

ÍNDICE

INDEX

1. ELEMENTOS DE PUNZONADO / PUNCHING ELEMENTS	4
PUNZONES / PUNCHES	
PORTA PUNZONES / PUNCH RETAINERS	
MATRICES / MATRIXES	
DESPEGADORES / STRIPPERS	
EXPULSORES / EJECTORS	
<hr/>	
2. ELEMENTOS DE GUIADO / SLIDING ELEMENTS	86
PORTAMATRICES / DIE SETS	
COLUMNAS GUÍA / GUIDE PILLARS	
CASQUILLOS GUÍA / GUIDE BUSHES	
JAULAS DE BOLAS / BALL CAGES	
CASQUILLOS DE BOLAS / BALL GUIDE BUSHES	
PLACAS / WEAR PLATES	
ESCUADRAS / ANGULAR GUIDES	
GUÍAS EN "V" / "V" DRIVERS	
GUÍAS CARRO / CAM WEAR PLATES	
ELEMENTOS DE AMARRE / FASTENING ELEMENTS	
<hr/>	
3. ELEMENTOS DE RECUPERACIÓN / RECOVERY ELEMENTS	222
MUELLES / SPRINGS	
ELASTÓMEROS / ELASTOMERS	
POSICIONADOR DE MUELLE / BALL PLUNGER	
EXPULSORES DE MUELLE / SPRING PLUNGERS	
EXPULSORES DE GAS / GAS EJECTORS	
CILINDROS / GAS SPRINGS	
ELEMENTOS DE AMARRE / FASTENING ELEMENTS	
<hr/>	
4. ELEMENTOS DE SUJECIÓN / FASTENING ELEMENTS	342
BRIDAS DE AMARRE RÁPIDO / COMBINED SLIDING CLAMP	
ARANDELAS / WASHERS	
TORNILLOS Y TUERCAS / SCREWS & NUTS	
PASADORES / DOWEL PINS	
CASQUILLO DE RETENCIÓN / DOWEL PIN RETAINING SLEEVE	
IMANES Y BASES MAGNÉTICAS / MAGNETS & MAGNETIC BASES	

5. ELEMENTOS DE TRANSPORTE / LIFTING ELEMENTS	380
CÁNCAMOS / BRACKETS	
OREJETAS DE TRANSPORTE / LIFTING BRACKETS WITH PIN	
BULONES DE TRANSPORTE / LIFTING PINS	
BOLA TRANSPORTADORA / TRANSPORTATION BALL	
<hr/>	
6. ELEMENTOS DE TRAZABILIDAD / TRACEABILITY ELEMENTS	396
MARCADORES / STAMPS	
PORTAMARCADORES / STAMP RETAINERS	
<hr/>	
7. ACEROS Y LÁMINAS / STEEL AND SHEETS	408
PLACAS DE ACERO RECTIFICADAS / PRECISION GROUND PLATES	
CINTA CALIBRADA / PRECISION FOILS	
CHAPA LAGRIMADA / PATTERNED METAL SHEETS	
ACERO PLATA / STEEL SILVER	
<hr/>	
8. CENTRAJE Y DETECCIÓN / CENTERING & DETECTION ELEMENTS	420
DETECTORES / FEEDCONTROLS	
CENTRADORES EN L / CAGES	
SENSORES / SENSORS	
CONECTORES / CONNECTORS	
CONOS DE CENTRAJE / CENTERING CONES	
MUÑEQUILLAS / LOCATING PINS	
<hr/>	
9. CARROS / CAM UNITS	434
CARROS AÉREOS / AERIAL CAM UNITS	
CARROS DE RODILLO / ROLLER CAM UNITS	
CARROS DE BASE INFERIOR / DIE MOUNTED CAM UNITS	
CARROS ESPECIALES / SPECIAL CAM UNITS	
CARROS PERSONALIZADOS / CUSTOMIZED CAM UNITS	
<hr/>	
10. INFORMACIÓN TÉCNICA / TECHNICAL DATA	446

ELEMENTOS DE PUNZONADO PUNCHING ELEMENTS



La industria del estampado de metales requiere de herramientas de precisión adecuadas para cada aplicación. En este apartado podrás encontrar todo tipo de componentes de punzonado necesarios en el proceso de estampación.

La elección de los elementos adecuados de punzonado es la clave para mejorar la vida útil de la herramienta, reducir el tiempo de inactividad y mejorar la productividad.

Además, podemos diseñar y fabricar productos especiales de punzonado, para dar solución a necesidades específicas de producción.

The metal stamping industry requires adequate precision tools for each of its functions. In this section you will find all types of punching elements for the stamping process.

Choosing the adequate stamping tools is key to be able to prolong the life of the tool, to reduce inactivity and to better productivity.

In addition, we can design and manufacture special punching elements, according to special designs and particular production needs.

ELEMENTOS DE PUNZONADO

PUNCHING ELEMENTS



ÍNDICE INDEX

12

PUNZÓN CABEZA CÓNICA RPDA
CONICAL HEAD PUNCH RPDA



DIN 9861 DA

13

PUNZÓN CABEZA CÓNICA RPGB
CONICAL HEAD PUNCH RPGB



DIN 9861 D

14

**PUNZÓN CABEZA CÓNICA,
CON FORMA RPDC**
CONICAL HEAD PUNCH,
STEPPED RPDC



-

15

**PUNZÓN CABEZA CÓNICA,
MECHADO RPG**
CONICAL HEAD PUNCH,
STEPPED RPG



-

16

**PUNZÓN CABEZA CÓNICA CON
EXPULSOR, EN BRUTO RPLB**
CONICAL HEAD PUNCH WITH
EJECTOR, BLANK RPLB



-

17

**PUNZÓN CABEZA CÓNICA CON
EXPULSOR, MECHADO RPL**
CONICAL HEAD PUNCH WITH
EJECTOR, STEPPED RPL



-

18

**PUNZÓN DE EMBUTICIÓN,
CABEZA CÓNICA RPNC**
CONICAL HEAD DRAW
PUNCH RPNC



-

19

PRESTOLA RPRE
PRESTAM RPRE



-

20

**PUNZÓN CABEZA CILÍNDRICA,
EN BRUTO RPTB**
CYLINDRICAL HEAD PUNCH,
BLANK RPTB



DIN 9844 A

21

**PUNZÓN CABEZA CILÍNDRICA
MECHADO RPTC**
CYLINDRICAL HEAD PUNCH,
STEPPED RPTC



DIN 9844 B

22

**PUNZÓN CABEZA 30°,
EN BRUTO RPMB**
30° HEADED PUNCH,
BLANK RPMB



-

23

**PUNZÓN CABEZA 30°,
MECHADO RPM**
30° HEADED PUNCH, STEPPED
RPM



-

24

**PUNZÓN CUELLO DE BOTELLA,
EN BRUTO RPSB**
BOTTLE-NECK PUNCH, BLANK
RPSB



DIN 5118 A

25

**PUNZÓN CUELLO DE BOTELLA,
MECHADO RPS**
BOTTLE-NECK PUNCH, STEPPED
RPS



DIN 5118 B

26

**PUNZÓN CUELLO DE BOTELLA
CON EXPULSOR, EN BRUTO RPXB**
BOTTLE-NECK PUNCH WITH
EJECTOR, BLANK RPXB



DIN 5118 E

27

**PUNZÓN CUELLO DE BOTELLA
CON EXPULSOR, MECHADO RPX**
BOTTLE-NECK PUNCH WITH
EJECTOR, STEPPED RPX



DIN 5118 F

28

FRESA PARA CUELLO BOTELLA
RFPA
ENDMILL FOR BOTTLE-NECK
PUNCH **RFPA**



29

CAMISA PARA PUNZÓN
CUELLO BOTELLA RPPC
SLEEVE FOR BOTTLE-NECK
PUNCH **RPPC**



30

PORTA PUNZÓN PARA CUELLO
BOTELLA RPPB
BOTTLE-NECK PUNCH RETAINER
RPPB



31

PORTA PUNZÓN PARA CUELLO
BOTELLA RPPBA
BOTTLE-NECK PUNCH RETAINER
RPPBA



32

PUNZÓN CABEZA CILÍNDRICA,
EN BRUTO RPAB
CYLINDRICAL HEAD PUNCH,
BLANK **RPAB**



ISO 8020 A

33

PUNZÓN CABEZA CILÍNDRICA,
MECHADO RPA
CYLINDRICAL HEAD PUNCH,
STEPPED **RPA**



ISO 8020 B

34

PUNZÓN CABEZA CILÍNDRICA
CON EXPULSOR, EN BRUTO RPBB
CYLINDRICAL HEAD PUNCH WITH
EJECTOR, BLANK **RPBB**



ISO 8020 E

35

PUNZÓN CABEZA CILÍNDRICA
CON EXPULSOR, MECHADO RPB
CYLINDRICAL HEAD PUNCH WITH
EJECTOR, STEPPED **RPB**



ISO 8020 F

36

PUNZÓN CABEZA CILÍNDRICA,
EN BRUTO RPAX
CYLINDRICAL HEAD PUNCH,
BLANK **RPAX**



37

PUNZÓN CABEZA CILÍNDRICA
CON EXPULSOR, EN BRUTO
RPBX
CYLINDRICAL HEAD PUNCH WITH
EJECTOR, BLANK **RPBX**



38

PORTA PUNZÓN PARA CABEZA
CILÍNDRICA RPPi
RETAINER FOR CYLINDRICAL
HEAD **RPPi**



39

PORTA PUNZÓN PARA CABEZA
CILÍNDRICA RPPiA
RETAINER FOR CYLINDRICAL
HEAD **RPPiA**



40

PORTA PUNZÓN PARA CABEZA
CILÍNDRICA RPPF
RETAINER FOR CYLINDRICAL
HEAD **RPPF**



41

PORTA PUNZÓN PARA CABEZA
CILÍNDRICA RPPFA
RETAINER FOR CYLINDRICAL
HEAD **RPPFA**



42

PUNZÓN CABEZA REFORZADA,
EN BRUTO RPBV
REINFORCED HEAD PUNCH,
BLANK **RPBV**



43

PUNZÓN CABEZA REFORZADA,
MECHADO RPBV
REINFORCED HEAD PUNCH,
STEPPED **RPBV**



44

**PUNZÓN CABEZA REFORZADA
CON EXPULSOR, EN BRUTO RPZB**
REINFORCED HEAD PUNCH WITH
EJECTOR, BLANK RPZB



45

**PUNZÓN CABEZA REFORZADA
CON EXPULSOR, MECHADO RPZ_**
REINFORCED HEAD PUNCH WITH
EJECTOR, STEPPED RPZ_



46

**PORTA PUNZÓN PARA CABEZA
REFORZADA RPPX**
RETAINER FOR REINFORCED
HEAD RPPX



47

**PORTA PUNZÓN PARA CABEZA
REFORZADA RPPXA**
RETAINER FOR REINFORCED
HEAD RPPXA



48

**PUNZÓN CAMBIO RÁPIDO
CARGA FUERTE, EN BRUTO RPCB**
HEAVY DUTY BALL LOCK PUNCH,
BLANK RPCB



ISO 10071-2 A

49

**PUNZÓN CAMBIO RÁPIDO CARGA
FUERTE, MECHADO RPC_**
HEAVY DUTY BALL LOCK PUNCH,
STEPPED RPC_



ISO 10071-2 B

50

**PUNZÓN CAMBIO RÁPIDO
CARGA FUERTE CON
EXPULSOR, EN BRUTO RPDB**
HEAVY DUTY EJECTOR BALL
LOCK PUNCH, BLANK RPDB



ISO 10071-2 F

51

**PUNZÓN CAMBIO RÁPIDO
CARGA FUERTE CON
EXPULSOR, MECHADO RPD_**
HEAVY DUTY EJECTOR BALL
LOCK PUNCH, STEPPED RPD_



ISO 10071-2 F

52

**PUNZÓN CAMBIO RÁPIDO
CARGA FUERTE RPE_**
HEAVY DUTY BALL LOCK
PUNCH RPE_



53

**PUNZÓN CAMBIO RÁPIDO
CARGA FUERTE CON
EXPULSOR RPF_**
HEAVY DUTY BALL LOCK
PUNCH RPF_



54

**PORTA PUNZÓN DE CAMBIO
RÁPIDO PARA CARGA FUERTE
RPPH**
HEAVY DUTY BALL LOCK PUNCH
RETAINER RPPH



55

**PORTA PUNZÓN DE CAMBIO
RÁPIDO PARA CARGA FUERTE
RPPR**
HEAVY DUTY BALL LOCK PUNCH
RETAINER RPPR



56

MATRIZ LISA RMSA
HEADLESS MATRIX RMSA



DIN 9845 A

57

MATRIZ CON VALONA RMSB
HEADED MATRIX RMSB



DIN 9845 B

58

**MATRIZ LISA SALIDA RECTA, EN
BRUTO RMAB**
HEADLESS MATRIX
COUNTERBORE RELIEF, BLANK
RMAB



ISO 8977 C

59

**MATRIZ LISA AGUJERO
PASANTE, EN BRUTO RMCB**
HEADLESS MATRIX THRU HOLE,
BLANK RMCB



ISO 8977 E

60

MATRIZ CON VALONA SALIDA RECTA, EN BRUTO RMBB
HEADED MATRIX COUNTERBORE RELIEF, BLANK RMBB



ISO 8977 D

61

MATRIZ CON VALONA AGUJERO PASANTE, EN BRUTO RMDB
HEADED MATRIX THRU HOLE, BLANK RMDB



ISO 8977 F

62

MATRIZ LISA SALIDA RECTA, CON FORMA RMA_
HEADLESS MATRIX COUNTERBORE RELIEF, SHAPED RMA_



ISO 8977 A

63

MATRIZ LISA SALIDA CÓNICA, CON FORMA RME_
HEADLESS MATRIX TAPER RELIEF, SHAPED RME_



-

64

MATRIZ CON VALONA SALIDA RECTA, CON FORMA RMB_
HEADED MATRIX COUNTERBORE RELIEF, SHAPED RMB_



ISO 8977 B

65

MATRIZ CON VALONA SALIDA CÓNICA, CON FORMA RMF_
HEADED MATRIX TAPER RELIEF, SHAPED RMF_



-

66

MATRIZ LISA SALIDA RECTA CON ANTIRO, CON FORMA RMG_
KEY LOCATED HEADLESS MATRIX COUNTERBORE RELIEF, SHAPED RMG_



NFE 63080

67

MATRIZ REVERSIBLE, EN BRUTO RMHB
REVERSIBLE FLAT MATRIX, BLANK RMHB



-

67

MATRIZ REVERSIBLE, CON FORMA RMH_
REVERSIBLE FLAT MATRIX, SHAPED RMH_



-

68

CASQUILLO GUÍA PUNZÓN RMSC
PUNCH GUIDING BUSH RMSC



DIN 9845 C

69

BRIDA DE AMARRE PARA MATRIZ RBAM
CLAMP FOR MATRIX RBAM



-

69

BRIDA DE AMARRE PARA MATRIZ RBAF
CLAMP FOR MATRIX RBAF



-

70

TORNILLO DE AMARRE PARA MATRIZ RTAM
SCREW FOR MATRIX RTAM



-

70

BRIDA DE AMARRE PARA MATRIZ RAAM
CLAMP FOR MATRIX RAAM



-

71

DESPEGADOR DE URETANO RMTC
HEADLESS URETHANE STRIPPER RMTC



-

72

DESPEGADOR DE URETANO CON VALONA RMTS
HEADED URETHANE STRIPPER RMTS



-

73

BRIDA PARA DESPEGADOR DE URETANO CON VALONA **RMTR**
HEADED URETHANE STRIPPER RETAINER **RMTR**



-

74

BRIDA PARA DESPEGADOR DE URETANO CON VALONA **RMTP**
HEADED URETHANE STRIPPER RETAINER **RMTP**



-

75

ANTIQUIROS PARA PRODUCTOS CON CABEZA / VALONA **AG_**
LOCATING DEVICES FOR HEADED PRODUCTS **AG_**



-

76

ANTIQUIROS EN MATRIZ LISA **AG_**
LOCATING DEVICES IN HEADLESS MATRIX **AG_**



-

77

RANURA PARA PASADOR **AG_**
DOWEL SLOT **AG_**



-

78 - 79

ALTERACIONES ESTÁNDAR EN LONGITUD **AL1 - AL2 - AL3**
STANDARD ALTERATIONS IN LENGTH **AL1 - AL2 - AL3**



-

79

ALTERACIONES ESTÁNDAR EN CABEZA **AL_**
STANDARD ALTERATIONS IN HEAD **AL_**

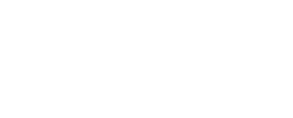

-

80

ALTERACIONES ESTÁNDAR EN DIAMETRO DE CUERPO **XD**
STANDARD ALTERATIONS IN BODY DIAMETER **XD**

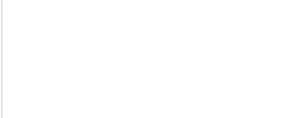

-

80

ALTERACIÓN DE CONTROL DE VIRUTA **CV**
SLUG CONTROL ALTERATION **CV**



-

81

TRATAMIENTOS Y RECUBRIMIENTOS
SURFACE TREATMENTS AND COATINGS

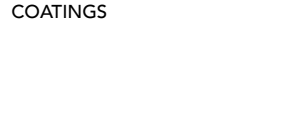

-

82

TOLERANCIAS PUNZÓN-MATRÍZ
PUNCH-DIE CLEARANCES



-

83

EXPULSOR NITRURADO **EXPA**
EJECTOR PIN BLACK NITRIDED **EXPA**



DIN 1530 - ISO 6751

84

EXPULSOR TEMPLADO CABEZA CILÍNDRICA **EXPB**
CYLINDRICAL HEAD EJECTOR PIN HARDENED **EXPB**



DIN 1530 - ISO 6752

85

EXPULSOR TEMPLADO CABEZA CÓNICA **EXPD**
CONICAL HEAD EJECTOR PIN HARDENED **EXPD**



DIN 1530

PUNZÓN CABEZA CÓNICA RPDA CONICAL HEAD PUNCH RPDA

Material: 1.2210 WS

Dureza cuerpo / Body hardness: 62 ±2HRC

Dureza cabeza / Head hardness: 45 ±5HRC

STOCK

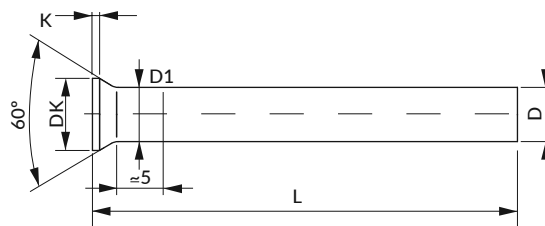

i También disponible en otros aceros y medidas bajo plano.
Also available in other steels and dimensions per dwg.

Norma / Standard: DIN 9861 DA

D	DK	D1 Max	K ₀ ^{+0,2}	L ₀ ^{+0,5}	
				71	80
0,5	0,9	D+0,02	0,2	•	•
0,55	1	D+0,02	0,2	•	•
0,6	1,1	D+0,02	0,2	•	•
0,65	1,2	D+0,02	0,2	•	•
0,7/0,75	1,3	D+0,02	0,2	•	•
0,8/0,85	1,4	D+0,02	0,4	•	•
0,9/0,95	1,6	D+0,02	0,4	•	•
1,0/1,1	1,8	D+0,03	0,5	•	•
1,15/1,3	2	D+0,03	0,5	•	•
1,35/1,5	2,2	D+0,03	0,5	•	•
1,55/1,7	2,5	D+0,03	0,5	•	•
1,75/1,9	2,8	D+0,03	0,5	•	•
1,95/2,0	3	D+0,03	0,5	•	•
2,05/2,2	3,2	D+0,03	0,5	•	•
2,25/2,5	3,5	D+0,03	0,5	•	•
2,55/2,95	4	D+0,03	0,5	•	•
3,0/3,45	4,5	D+0,03	0,5	•	•
3,5/3,95	5	D+0,03	0,5	•	•
4,0/4,45	5,5	D+0,03	0,5	•	•
4,5/4,95	6	D+0,03	0,5	•	•
5,0/5,45	6,5	D+0,03	0,5	•	•
5,5/5,95	7	D+0,03	0,5	•	•
6,0/6,4	8	D+0,03	0,5	•	•
6,5/7,4	9	D+0,04	1	•	•
7,5/8,4	10	D+0,04	1	•	•
8,5/9,4	11	D+0,04	1	•	•
9,5/10,4	12	D+0,04	1	•	•
10,5/11,4	13	D+0,04	1	•	•
11,5/12,4	14	D+0,04	1	•	•
12,5/13,4	15	D+0,04	1	•	•
13,5/14,4	16	D+0,04	1,5	•	•
14,5/15	17	D+0,04	1,5	•	•
15,1/16	18	D+0,04	1,5	•	•
16,1/17	19	D+0,04	1,5	•	•
17,1/18	20	D+0,04	1,5	•	•
18,1/19	21	D+0,04	1,5	•	•
19,1/20	22	D+0,04	1,5	•	•

Forma de pedido / How to order:

Indicar / Specify	RPDA	D	L	Mat.
Ejemplo / Example	RPDA	5	71	WS
Ejemplo / Example	RPDA	13,5	80	WS

PUNZÓN CABEZA CÓNICA RPGB CONICAL HEAD PUNCH RPGB

Material: 1.2379 HWS

Dureza cuerpo / Body hardness: 62 ±2HRC

Dureza cabeza / Head hardness: 45 ±5HRC

STOCK



i También disponible en otros aceros y medidas bajo plano.
Also available in other steels and dimensions per dwg.

Material: 1.3343 HSS

Dureza cuerpo / Body hardness: 64 ±2HRC

Dureza cabeza / Head hardness: 50 ±5HRC

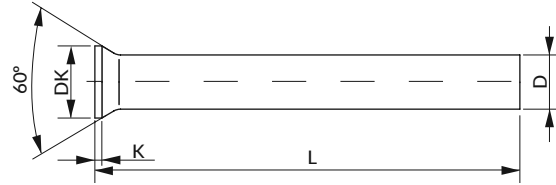

Norma / Standard: DIN 9861 D

D ^{h6}	DK	K ^{+0,2 0}	L ^{+0,5 0}			
			71	80	100	130*
0,5	0,9	0,2	•	•	•	-
0,55	1	0,2	•	•	•	-
0,6	1,1	0,2	•	•	•	-
0,65	1,2	0,2	•	•	•	-
0,7/0,75	1,3	0,2	•	•	•	-
0,8/0,85	1,4	0,4	•	•	•	-
0,9/0,95	1,6	0,4	•	•	•	-
1,0/1,1	1,8	0,5	•	•	•	•
1,15/1,3	2	0,5	•	•	•	•
1,35/1,5	2,2	0,5	•	•	•	•
1,55/1,7	2,5	0,5	•	•	•	•
1,75/1,9	2,8	0,5	•	•	•	•
1,95/2,0	3	0,5	•	•	•	•
2,05/2,2	3,2	0,5	•	•	•	•
2,25/2,5	3,5	0,5	•	•	•	•
2,55/2,95	4	0,5	•	•	•	•
3,0/3,45	4,5	0,5	•	•	•	•
3,5/3,95	5	0,5	•	•	•	•
4,0/4,45	5,5	0,5	•	•	•	•
4,5/4,95	6	0,5	•	•	•	•
5,0/5,45	6,5	0,5	•	•	•	•
5,5/5,95	7	0,5	•	•	•	•
6,0/6,4	8	0,5	•	•	•	•
6,5/7,4	9	1	•	•	•	•
7,5/8,4	10	1	•	•	•	•
8,5/9,4	11	1	•	•	•	•
9,5/10,4	12	1	•	•	•	•
10,5/11,4	13	1	•	•	•	•
11,5/12,4	14	1	•	•	•	•
12,5/13,4	15	1	•	•	•	•
13,5/14,4	16	1,5	•	•	•	•
14,5/15	17	1,5	•	•	•	•
15,1/16	18	1,5	•	•	•	•
16,1/17	19	1,5	•	•	•	•
17,1/18	20	1,5	•	•	•	•
18,1/19	21	1,5	•	•	•	•
19,1/20	22	1,5	•	•	•	•
21	23	1,5	•	•	•	•
22	24	1,5	•	•	•	•
23	25	1,5	•	•	•	•
24	26	1,5	•	•	•	•
25	27	1,5	•	•	•	•

Forma de pedido / How to order:

Indicar / Specify	RPGB	D	L	Mat.
Ejemplo / Example	RPGB	5	71	HWS
Ejemplo / Example	RPGB	13,5	80	HWS

*L130 sólo en HSS / L 130 only in HSS

PUNZÓN CABEZA CÓNICA, MECHADO RPDC CONICAL HEAD PUNCH, STEPPED RPDC

Material: 1.3343 HSS

Dureza cuerpo / Body hardness: 64 ±2HRC

Dureza cabeza / Head hardness: 50 ±5HRC

STOCK



i También disponible en otros aceros y medidas bajo plano.
Also available in other steels and dimensions per dwg.

i Opciones de recubrimiento en pág. 81.
See page 81 for coating options.

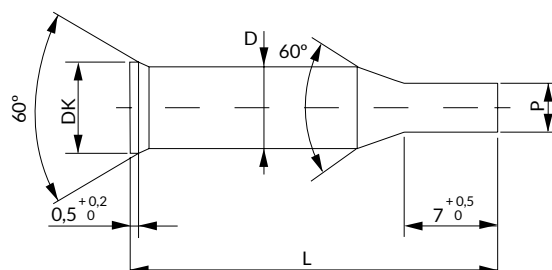

Norma / Standard: DIN 9861 C

p h6	D h6	DK	L ^{+0,5} ₀
0,5 - 1,5	2	3	71
1,55 - 2,95	3	4,5	71

Forma de pedido / How to order:

Indicar / Specify	RPDC	D	L	Mat.	P
Ejemplo / Example	RPDC	2	71	HSS	P0,5
Ejemplo / Example	RPDC	3	71	HSS	P2,0

PUNZÓN CABEZA CÓNICA, MECHADO RPG_ CONICAL HEAD PUNCH, STEPPED RPG_

Material: 1.2379 HWS
Dureza cuerpo / Body hardness: 62 ±2HRC
Dureza cabeza / Head hardness: 45 ±5HRC

Material: 1.3343 HSS
Dureza cuerpo / Body hardness: 64 ±2HRC
Dureza cabeza / Head hardness: 50 ±5HRC



i También disponible en otros aceros y medidas bajo plano.
Also available in other steels and dimensions per dwg.

i Opciones de recubrimiento en pág. 81.
See page 81 for coating options.

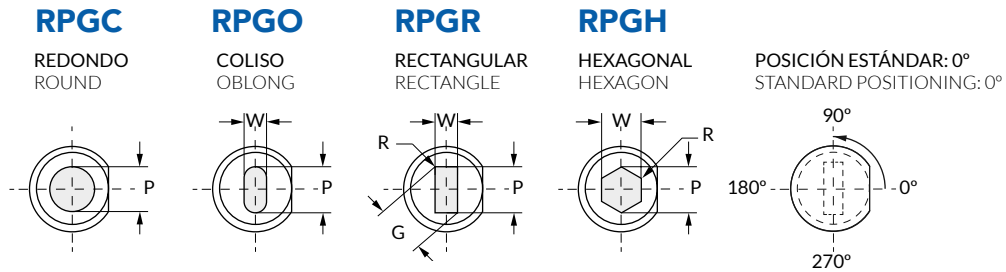
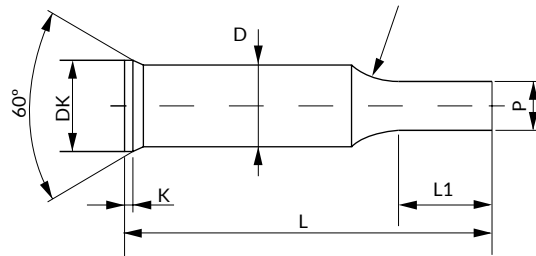

i Indicar anti giro (AG_) en pedido. Ver anti giros (pág 75)
Specify locating device type (AG_) in your order. See locating device section (page 75)

D ^{m5}	Redondo Round	Forma / Shape		Cabeza / Head		^{+0,5} L ₀										L1	
	P	Min W	Max G/P	DK ^{+0,1}	K ^{+0,2}	50	56	60	63	70	71	80	90	100	Estándar/ Standard	Max	
6	1,6 - 5,99	1,6	6	8	0,5	•	•	•	•	•	•	•	•	•	•	8	13
8	2,5 - 7,99	2,5	8	10	1	•	•	•	•	•	•	•	•	•	•	13	19
10	3,2 - 9,99	3,2	10	12	1	•	•	•	•	•	•	•	•	•	•	19	25
13	5 - 12,9	4,5	13	15	1	•	•	•	•	•	•	•	•	•	•	19	25
16	8 - 15,9	6	16	18	1,5	•	•	•	•	•	•	•	•	•	•	19	25
20	10 - 19,99	8	20	22	1,5	-	•	•	•	•	•	•	•	•	•	19	25
25	12 - 24,99	9	25	27	1,5	-	•	•	•	•	•	•	•	•	•	19	25

Posibilidad de fabricación en otros diámetros según punzón RPGB (DIN 9861 D). Ver pág. 13.
Possibility of manufacturing in other diameters, regarding RPGB punch (DIN 9861 D). See page 13.

Forma de pedido / How to order:

Indicar / Specify	RPG_	D	L	Mat.	P o PxW	L1	AG_
Ejemplo / Example	RPGC	8	70	HWS	P3,0	L1=19	AG1
Ejemplo / Example	RPGO	13	80	HSS	P12,0 W6,9	L1=24	AG2

PUNZÓN CABEZA CÓNICA CON EXPULSOR, EN BRUTO RPLB CONICAL HEAD PUNCH WITH EJECTOR, BLANK RPLB

Material: 1.2379 HWS

Dureza cuerpo / Body hardness: 62 ±2HRC

Dureza cabeza / Head hardness: 45 ±5HRC

Material: 1.3343 HSS

Dureza cuerpo / Body hardness: 64 ±2HRC

Dureza cabeza / Head hardness: 50 ±5HRC



i También disponible en otros aceros y medidas bajo plano.
Also available in other steels and dimensions per dwg.

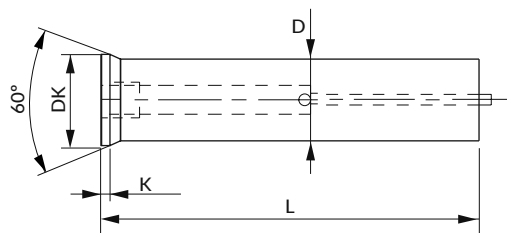

D ^{m5}	Cabeza / Head		L ^{+0,5} ₀									
	DK ±0,1	K ±0,2	50	56	60	63	70	71	80	90	100	
6	8	0,5	•	•	•	•	•	•	•	•	•	•
8	10	1	•	•	•	•	•	•	•	•	•	•
10	12	1	•	•	•	•	•	•	•	•	•	•
13	15	1	•	•	•	•	•	•	•	•	•	•
16	18	1,5	•	•	•	•	•	•	•	•	•	•
20	22	1,5	-	•	•	•	•	•	•	•	•	•
25	27	1,5	-	•	•	•	•	•	•	•	•	•

Forma de pedido / How to order:

Indicar / Specify	RPLB	D	L	Mat.
Ejemplo / Example	RPLB	10	71	HWS
Ejemplo / Example	RPLB	16	80	HWS

PUNZÓN CABEZA CÓNICA CON EXPULSOR, MECHADO RPL_ CONICAL HEAD PUNCH WITH EJECTOR, STEPPED RPL_

Material: 1.2379 HWS
Dureza cuerpo / Body hardness: 62 ±2HRC
Dureza cabeza / Head hardness: 45 ±5HRC

Material: 1.3343 HSS
Dureza cuerpo / Body hardness: 64 ±2HRC
Dureza cabeza / Head hardness: 50 ±5HRC



i También disponible en otros aceros y medidas bajo plano.
Also available in other steels and dimensions per dwg.

i Opciones de recubrimiento en pág. 81.
See page 81 for coating options.

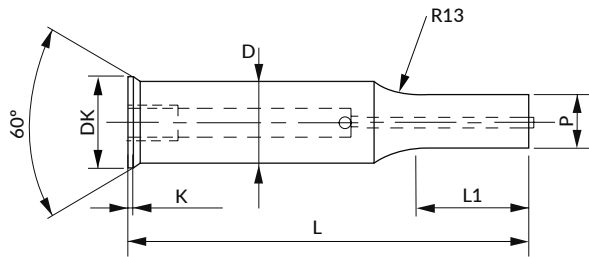

RPLC

REDONDO
ROUND

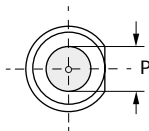

RPLO

COLISO
OBLONG

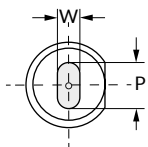

RPLR

RECTANGULAR
RECTANGLE

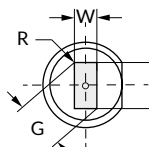

RPLH

HEXAGONAL
HEXAGON

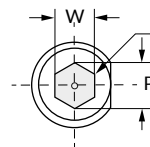

POSICIÓN ESTÁNDAR: 0°
STANDARD POSITIONING: 0°

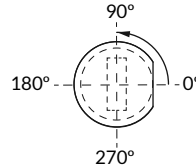

i Indicar anti giro (AG_) en pedido. Ver anti giros (pág 75)
Specify locating device type (AG_) in your order. See locating device section (page 75)

D _{m5}	Redondo Round	Forma / Shape		Cabeza / Head		L ^{+0,5} ₀										L1 Max
	P	Min W	Max G/P	DK ^{+0,1} ₀	K ^{+0,2} ₀	50	56	60	63	70	71	80	90	100		
6	2,50 - 5,99	1,6	5	8	0,5	•	•	•	•	•	•	•	•	•	•	13
8	3,20 - 7,99	3,2	8	10	1	•	•	•	•	•	•	•	•	•	•	19
10	4,50 - 9,99	4,5	10	12	1	•	•	•	•	•	•	•	•	•	•	25
13	6 - 12,99	6	13	15	1	•	•	•	•	•	•	•	•	•	•	25
16	8 - 15,99	7,5	16	18	1,5	•	•	•	•	•	•	•	•	•	•	25
20	10 - 19,99	8	20	22	1,5	-	•	•	•	•	•	•	•	•	•	25
25	12 - 24,99	9	25	27	1,5	-	•	•	•	•	•	•	•	•	•	25

Forma de pedido / How to order:

Indicar / Specify	RPL_	D	L	Mat.	P o PxW	L1	AG_
Ejemplo / Example	RPLC	8	70	HWS	P3,0	L1=19	AG1
Ejemplo / Example	RPLO	13	80	HSS	P12,0W6,0	L1=24	AG2

PUNZÓN DE EMBUTICIÓN, CABEZA CÓNICA RPNC CONICAL HEAD DRAW PUNCH RPNC

Material: 1.3343 HSS

Dureza cuerpo / Body hardness: 64 ±2HRC

Dureza cabeza / Head hardness: 50 ±5HRC

STOCK



i También disponible en otros aceros y medidas bajo plano.
Also available in other steels and dimensions per dwg.

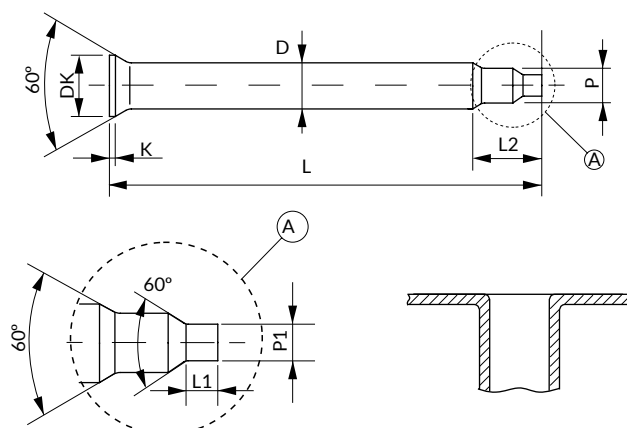

Rosca / Thread	P1 ^{h6}	DK	D ^{h6}	P	L	L1	L2	K
M2	1,0	4,5	3	1,60	75	1,5	10	0,5
M2,5	1,1	4,5	3	2,10	75	2,0	10	0,5
M3	1,3	4,5	3	2,55	75	2,5	10	0,5
M4	2,0	5,5	4	3,40	80	3,0	10	0,5
M5	2,7	6,5	5	4,30	80	3,5	10	0,5
M6	3,4	8,0	6	5,10	80	3,5	10	0,5
M8	4,2	10	8	6,90	80	4,0	12	1

Forma de pedido / How to order:

Indicar / Specify RPNC Rosca / Thread
Ejemplo / Example RPNC M4

PRESTOLA RPRE
PRESTAM RPRE

Material: 1.3343 HSS
Dureza / Hardness: 60-64 HRC

STOCK



Punzón / Punch

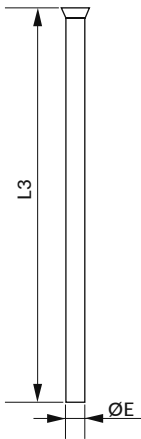

Punzón de embutición / Drawing punch

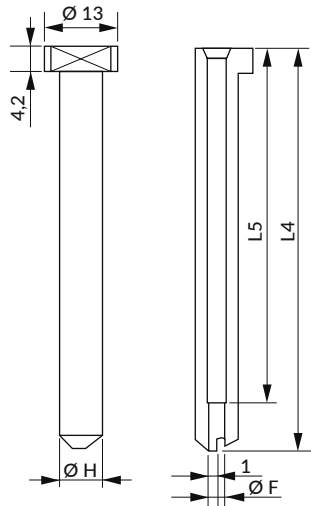

Matriz / Matrix

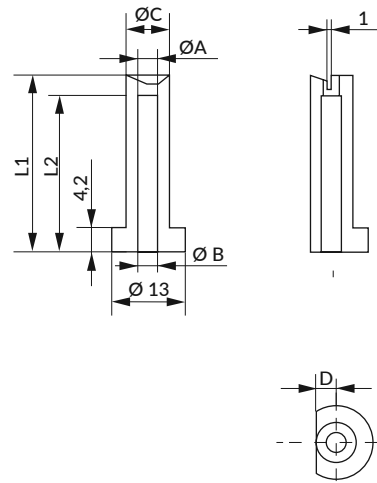

Ø Tornillo Ø Screw	Ø A H7	Ø B	Ø C H6	D K6	Ø E h6	Ø F h6	Ø H h6	I K6	L1	L2	L3	L4	L5	Espesor Max. Max. Thickness
B3,5	2,75	3,2	7,5	3,75	2,7	2,7	7,5	3,75	31,3	28	74,5	71,5	60	0,6
B3,9	3,05	3,4	7,5	3,75	3	3	7,5	3,75	31,3	28	74,5	71,5	60	0,6
B4,2	3,15	3,5	8,5	4,25	3,1	3,1	8	4	31,3	28	74,5	71,5	60	0,8
B4,8	3,85	4,2	9	4,5	3,8	3,8	8	4	31,3	28	74,5	71,5	60	0,9
B5,5	4,35	4,8	9	4,5	4,3	4,3	8	4	31,3	28	74,5	71,5	60	1
B6,3	4,85	5,3	10,5	5,25	4,8	4,8	10	5	31,3	28	74,5	71,5	60	1

Forma de pedido / How to order:

Indicar / Specify RPRE Ø Tornillo / Screw
Ejemplo / Example RPRE B4,2

PUNZÓN CABEZA CILÍNDRICA, EN BRUTO RPTB CYLINDRICAL HEAD PUNCH, BLANK RPTB

Material: 1.3343 HSS

Dureza cuerpo / Body hardness: $64 \pm 2\text{HRC}$

Dureza cabeza / Head hardness: $50 \pm 5\text{HRC}$



i También disponible en otros aceros y medidas bajo plano.
Also available in other steels and dimensions per dwg.

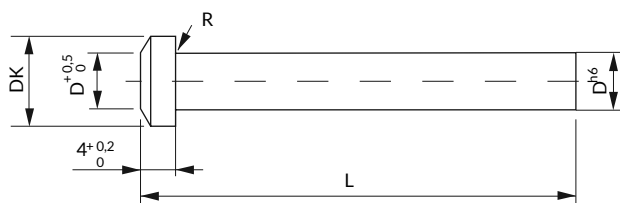

Norma / Standard: DIN 9844 A

D	DK ⁰ _{-0,1}	R	L ^{+0,5} ₀		
			71	90	112
2-2,2	3,6	0,2	•	•	•
2,3-2,5	4	0,2	•	•	•
2,6-2,8	4,5	0,3	•	•	•
2,9-3,2	5	0,3	•	•	•
3,3-3,5	6	0,3	•	•	•
3,6-4	7	0,3	•	•	•
4,1-4,5	8	0,5	•	•	•
4,6-5	8,5	0,5	•	•	•
5,1-5,4	9	0,5	•	•	•
5,5-5,9	9,5	0,5	•	•	•
6-6,4	10	0,5	•	•	•
6,5-7	10,8	0,7	•	•	•
7,5-8	12	0,7	•	•	•
8,5-9	13	0,7	•	•	•
9,5-10	14,5	0,7	•	•	•
10,5-11	16	1	•	•	•
11,5-12,5	18	1	•	•	•
13-14,5	20	1	•	•	•
15-16	22	1	•	•	•

Forma de pedido / How to order:

Indicar / Specify	RPTB	D	L	Mat.
Ejemplo / Example	RPTB	5,5	71	HSS
Ejemplo / Example	RPTB	10	112	HSS

PUNZÓN CABEZA CILÍNDRICA MECHADO RPTC CYLINDRICAL HEAD PUNCH, STEPPED RPTC

Material: 1.3343 HSS

Dureza cuerpo / Body hardness: 64 ±2HRC

Dureza cabeza / Head hardness: 50 ±5HRC



i También disponible en otros aceros y medidas bajo plano.
Also available in other steels and dimensions per dwg.

i Opciones de recubrimiento en pág. 81.
See page 81 for coating options.

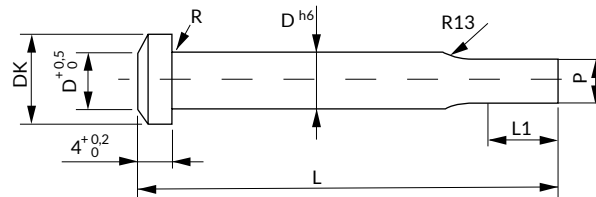

Norma / Standard: DIN 9844 B

P ^{h6}	D	DK ⁰ _{-0,1}	R	L1	L ^{+0,5} ₀		
					71	90	112
0,1-1,9	2	3,6	0,2	7	•	•	•
1,95-2,4	2,5	4	0,2	7	•	•	•
2,5-3,1	3,2	5	0,3	7	•	•	•
3,2-3,9	4	7	0,3	7	•	•	•
4-4,9	5	8,5	0,5	7	•	•	•
5-6,2	6,3	10	0,5	7	•	•	•
6,3-7,9	8	12	0,7	16	•	•	•
8-9,9	10	14,5	0,7	16	•	•	•
10-12,4	12,5	18	1	16	•	•	•
12,5-15,9	16	22	1	16	•	•	•

Forma de pedido / How to order:

Indicar / Specify	RPTC	D	L	Mat.	P	L1
Ejemplo / Example	RPTC	5	71	HSS	P=4,5	L1=7
Ejemplo / Example	RPTC	10	112	HSS	P=9,9	L1=16

PUNZÓN CABEZA 30°, EN BRUTO RPMB

30° HEADED PUNCH, BLANK RPMB

Material: 1.3343 HSS

Dureza cuerpo / Body hardness: 64 ±2HRC

Dureza cabeza / Head hardness: 50 ±5HRC

STOCK



i También disponible en otros aceros y medidas bajo plano.
Also available in other steels and dimensions per dwg.

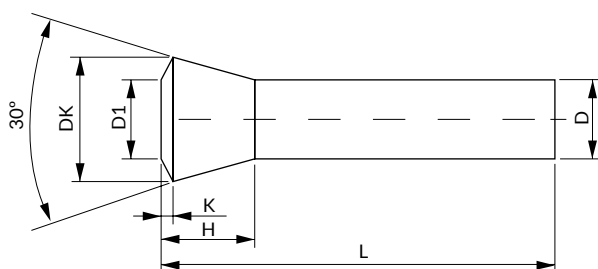

D ^{h6}	Cabeza / Head				L ^{+1,0} ₀					
	DK ⁰ _{-0,3}	D1	H	K	70	80	90	100	120	140
4	6,6	3,8	6	1	•	•	•	•	-	-
5	8,2	5	7	1	•	•	•	•	•	-
6	9,7	6	8	1	•	•	•	•	•	-
7	11,8	7	10	1	•	•	•	•	•	-
8	12,8	8	10	1	•	•	•	•	•	-
9	14,4	9	11	1	•	•	•	•	•	-
10	15,9	10	12	1	•	•	•	•	•	-
11	17,4	11	13	1,5	•	•	•	•	•	-
12	18,7	12	14	1,5	•	•	•	•	•	•
13	20,2	13	15	1,5	•	•	•	•	•	-
14	21,8	14	16	1,5	•	•	•	•	•	•
15	23,3	15	17	1,5	•	•	•	•	•	-
16	24,6	16	18	2	•	•	•	•	•	•

Forma de pedido / How to order:

Indicar / Specify	RPMB	D	L	Mat.
Ejemplo / Example	RPMB	10	70	HSS
Ejemplo / Example	RPMB	16	80	HSS

PUNZÓN CABEZA 30°, MECHADO RPM_

30° HEADED PUNCH, STEPPED RPM_

Material: 1.3343 HSS
 Dureza cuerpo / Body hardness: 64 ±2HRC
 Dureza cabeza / Head hardness: 50 ±5HRC



- También disponible en otros aceros y medidas bajo plano.
Also available in other steels and dimensions per dwg.
- Opciones de recubrimiento en pág. 81.
See page 81 for coating options.

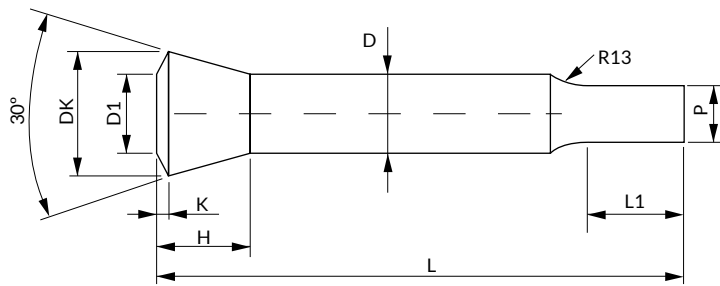

RPMC

REDONDO
ROUND

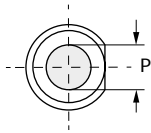

RPMO

COLISO
OBLONG

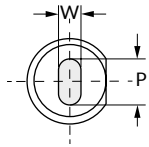

RPMR

RECTANGULAR
RECTANGLE

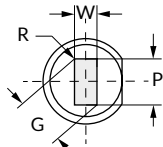

RPMH

HEXAGONAL
HEXAGON

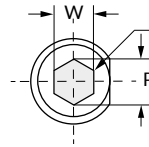

POSICIÓN ESTÁNDAR: 0°
STANDARD POSITIONING: 0°

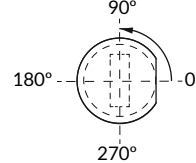

Indicar antigiro (AG_) en pedido. Ver antigiros (pág 75)
Specify locating device type (AG_) in your order. See locating device section (page 75)

D ^{h6}	Redondo Round	Forma / Shape		Cabeza / Head				L ⁺¹⁰ / ₀						L1 ^{+0,5} / ₀	
	P	MIN W	MAX G/P	DK ⁰ / _{-0,3}	DK	H	K	70	80	90	100	120	140	Estándar / Standard	Max
4	1,6 - 3,99	1,6	4	6,6	3,8	6	1	•	•	•	•	-	-	8	13
5	1,6 - 4,99	1,6	5	8,2	5	7	1	•	•	•	•	•	-	8	13
6	1,6 - 5,99	1,6	6	9,7	6	8	1	•	•	•	•	•	-	8	13
7	2,0 - 6,99	2,0	7	11,8	7	10	1	•	•	•	•	•	-	8	13
8	2,5 - 7,99	2,5	8	12,8	8	10	1	•	•	•	•	•	-	8	13
9	3,2 - 8,99	3,2	9	14,4	9	11	1	•	•	•	•	•	-	8	13
10	3,2 - 9,99	3,2	10	15,9	10	12	1	•	•	•	•	•	-	19	25
11	5 - 10,99	4,5	11	17,4	11	13	1,5	•	•	•	•	•	-	19	25
12	5 - 11,99	4,5	12	18,7	12	14	1,5	•	•	•	•	•	•	19	25
13	5 - 12,9	4,5	13	20,2	13	15	1,5	•	•	•	•	•	-	19	25
14	6 - 13,9	6,0	14	21,8	14	16	1,5	•	•	•	•	•	•	19	25
15	7 - 14,9	6,0	15	23,3	15	17	1,5	•	•	•	•	•	-	19	25
16	8 - 15,9	6,0	16	24,6	16	18	2	•	•	•	•	•	•	19	25

Forma de pedido / How to order:

Indicar / Specify	RPM_	D	L	Mat.	P o PxW	L1	AG_
Ejemplo / Example	RPMC	8	70	HSS	P3,0	L1=12	AG1
Ejemplo / Example	RPMO	13	80	HSS	P12,0W4,6	L1=17	AG2

PUNZÓN CUELLO DE BOTELLA, EN BRUTO RPSB BOTTLE-NECK PUNCH, BLANK RPSB

Material: 1.3343 HSS

Dureza cuerpo / Body hardness: $64 \pm 2\text{HRC}$

Dureza cabeza / Head hardness: $50 \pm 5\text{HRC}$

STOCK



i También disponible en otros aceros y medidas bajo plano.
Also available in other steels and dimensions per dwg.

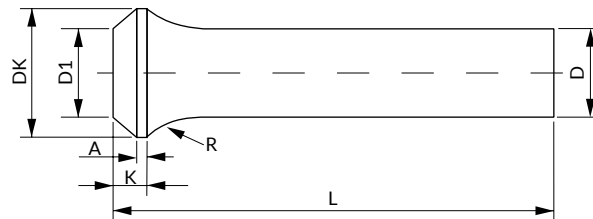

Norma / Standard: DIN 5118 A

D ^{h6}	Cabeza / Head					L ^{+0,5 0}				
	DK ^{0 -0,2}	K ^{+0,2 0}	A	D1 ^{+0,1 -0,1}	R ^{0 -0,2}	71	80	90	100	120
3	4	3	1	3	6,5	•	•	•	•	•
4	5,5	4	1,5	4	8	•	•	•	•	•
5	7	4	1,5	5	10	•	•	•	•	•
6	9	4	1,5	6	10	•	•	•	•	•
8	11	4	1,5	8	12	•	•	•	•	•
10	14	4	1,5	10	15	•	•	•	•	•
13	17	4	1,5	13	15	•	•	•	•	•
16	20	4	1,5	16	15	•	•	•	•	•
20	25	4	1,5	20	15	•	•	•	•	•

Forma de pedido / How to order:

Indicar / Specify	RPSB	D	L	Mat.
Ejemplo / Example	RPSB	10	71	HSS
Ejemplo / Example	RPSB	16	80	HSS

PUNZÓN CUELLO DE BOTELLA, MECHADO RPS_ BOTTLE-NECK PUNCH, STEPPED RPS_

Material: 1.3343 HSS

Dureza cuerpo / Body hardness: 64 ±2HRC

Dureza cabeza / Head hardness: 50 ±5HRC

i También disponible en otros aceros y medidas bajo plano.
Also available in other steels and dimensions per dwg.

i Opciones de recubrimiento en pág. 81.
See page 81 for coating options.

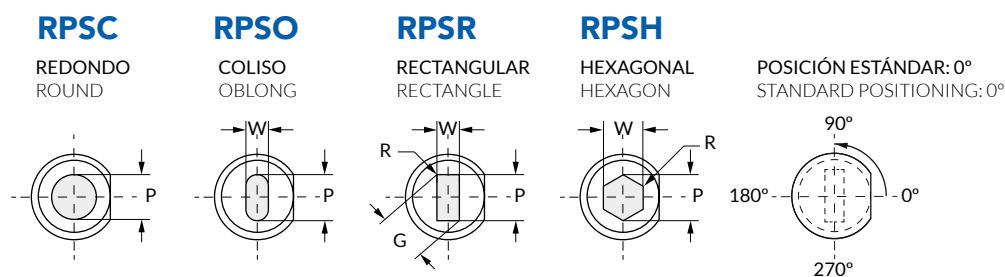
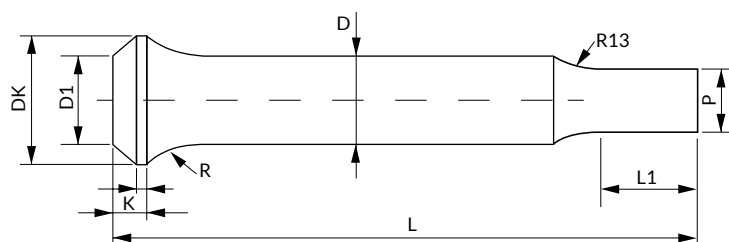

i Indicar anti giro (AG_) en pedido. Ver anti giros (pág 75)
Specify locating device type (AG_) in your order. See locating device section (page 75)

Norma / Standard: DIN 5118 B

D h ₆	Redondo Round	Forma / Shape		Cabeza / Head						L ^{+0,5} L ₀					L1	
	P	Min. W	Max. G/P	DK ⁰ -0,2	K ^{+0,2} 0	A	D1 ^{+0,1} -0,1	R ⁰ -0,2	71	80	90	100	120	Estándar / Standard	Max.	
3	0,8 - 2,9	1,6	3	4	3	1	3	6,5	•	•	•	•	•	8	13	
4	1 - 3,9	1,6	4	5,5	4	1,5	4	8	•	•	•	•	•	8	13	
5	1,5 - 4,9	1,6	5	7	4	1,5	5	10	•	•	•	•	•	13	19	
6	1,6 - 5,9	2,5	6	9	4	1,5	6	10	•	•	•	•	•	13	19	
8	2,5 - 7,9	3,2	8	11	4	1,5	8	12	•	•	•	•	•	19	25	
10	4 - 9,9	4,5	10	14	4	1,5	10	15	•	•	•	•	•	19	25	
13	5 - 12,9	6	13	17	4	1,5	13	15	•	•	•	•	•	19	25	
16	8 - 15,9	7,5	16	20	4	1,5	16	15	•	•	•	•	•	19	25	
20	12 - 19,9	8	20	25	4	1,5	20	15	•	•	•	•	•	19	25	

Forma de pedido / How to order:

Indicar / Specify	RPS_	D	L	Mat.	P o PxW	L1	AG_
Ejemplo / Example	RPSC	8	71	HSS	P3,0	L1=20	AG1
Ejemplo / Example	RPSO	13	80	HSS	P12,0 W6,0	L1=17	AG2

PUNZÓN CUELLO DE BOTELLA CON EXPULSOR, EN BRUTO RPXB BOTTLE-NECK PUNCH WITH EJECTOR, BLANK RPXB

Material: 1.3343 HSS

Dureza cuerpo / Body hardness: $64 \pm 2\text{HRC}$

Dureza cabeza / Head hardness: $50 \pm 5\text{HRC}$



i También disponible en otros aceros y medidas bajo plano.
Also available in other steels and dimensions per dwg.

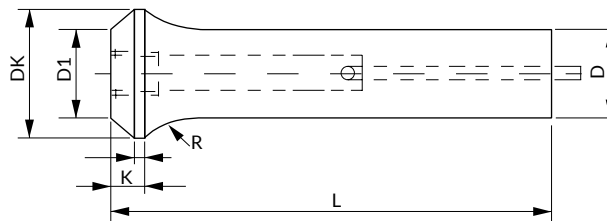

Norma / Standard: DIN 5118 E

D ^{h6}	Cabeza / Head					L ^{+0,5} ₀				
	DK ⁰ _{-0,2}	K ^{+0,2} ₀	A	D1 ^{+0,1} _{-0,1}	R ⁰ _{-0,2}	71	80	90	100	120
5	7	4	1,5	5	10	•	•	•	•	•
6	9	4	1,5	6	10	•	•	•	•	•
8	11	4	1,5	8	12	•	•	•	•	•
10	14	4	1,5	10	15	•	•	•	•	•
13	17	4	1,5	13	15	•	•	•	•	•
16	20	4	1,5	16	15	•	•	•	•	•
20	25	4	1,5	20	15	•	•	•	•	•

Forma de pedido / How to order:

Indicar / Specify	RPXB	D	L	Mat.
Ejemplo / Example	RPXB	10	71	HSS
Ejemplo / Example	RPSB	16	80	HSS

PUNZÓN CUELLO DE BOTELLA CON EXPULSOR, MECHADO RPX_ BOTTLE-NECK PUNCH WITH EJECTOR, STEPPED RPX_

Material: 1.3343 HSS
Dureza cuerpo / Body hardness: 64 ±2HRC
Dureza cabeza / Head hardness: 50 ±5HRC



- También disponible en otros aceros y medidas bajo plano.
Also available in other steels and dimensions per dwg.
- Opciones de recubrimiento en pág. 81.
See page 81 for coating options.

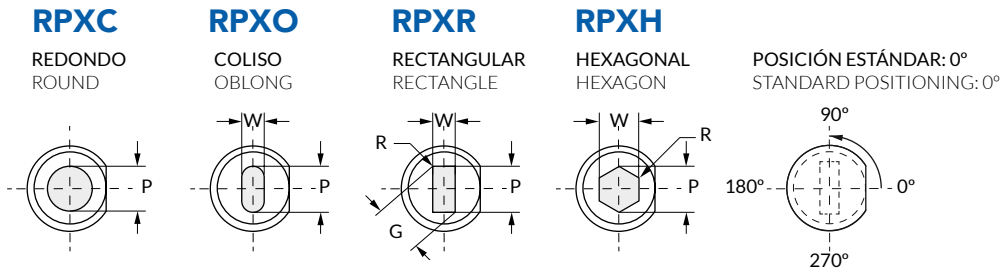
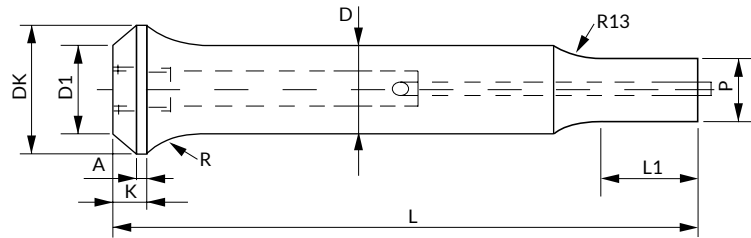

Indicar anti giro (AG_) en pedido. Ver anti giros (pág 75)
Specify locating device type (AG_) in your order. See locating device section (page 75)

Norma / Standard: DIN 5118 F

D h6	Redondo Round	Forma / Shape		Cabeza / Head						L ^{+0,5} ₀						L1	
	P	Min W	Max G/P	DK _{-0,2} ⁰	K ₀ ^{+0,2}	A	D1 _{-0,1} ^{+0,1}	R _{-0,2} ⁰	71	80	90	100	120	150	200	Estándar / Standard	Max.
5	1,6 - 4,9	1,6	5	7	4	1,5	5	10	•	•	•	•	•	-	-	13	19
6	2,5 - 5,9	2,5	6	9	4	1,5	6	10	•	•	•	•	•	-	-	13	19
8	2,5 - 7,9	3,2	8	11	4	1,5	8	12	•	•	•	•	•	-	-	19	25
10	4 - 9,9	4,5	10	14	4	1,5	10	15	•	•	•	•	•	-	-	19	25
13	5 - 12,9	6	13	17	4	1,5	13	15	•	•	•	•	•	•	•	19	25
16	8 - 15,9	7,5	16	20	4	1,5	16	15	•	•	•	•	•	•	•	19	25
20	12 - 19,9	8	20	25	4	1,5	20	15	•	•	•	•	•	•	•	19	25

Forma de pedido / How to order:

Indicar / Specify	RPX_	D	L	Mat.	P o PxW	L1	AG_
Ejemplo / Example	RPXC	8	71	HSS	P3,0	L1=20	AG1
Ejemplo / Example	RPXO	13	80	HSS	P12,0 W6,0	L1=17	AG2

FRESA PARA CUELLO BOTELLA RFPA ENDMILL FOR BOTTLE-NECK PUNCH RFPA

Material: 1.3343 HSS
Dureza / Hardness: 64±2HRC

Fresa para alojamiento cabeza punzón RPX_
Endmill for making holes for RPX_ punches

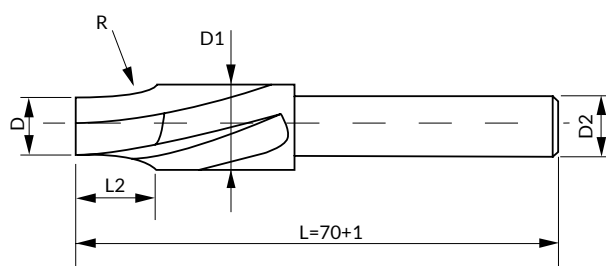

D ^{f7}	D1 ^{h8}	D2 ^{h11}	R ^{+0,01 0}	L2
5	7,4	7,4	10	10
6	9,5	9,5	10	10
8	11,5	11,5	12	12
10	14,5	13	15	12
13	17,5	13	15	15
16	20,5	13	15	15
20	25,5	16	15	15

Forma de pedido: RFPA + D
How to order: RFPA + D

CAMISA PARA PUNZÓN CUELLO BOTELLA RPPC SLEEVE FOR BOTTLE-NECK PUNCH RPPC

Material: 1.2312 HWS

Resistencia / Resistance: ~ 1080 N/mm²



Para punzones RPSB, RPSC, RPXB y RPXC
For punches RPSB, RPSC, RPXB and RPXC

Dimensiones recomendadas para alojamiento
Recommended retainer dimensions

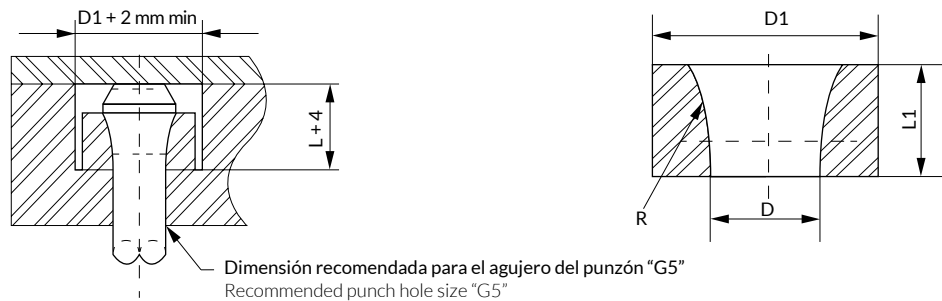

D ^{h8}	R ^{0 -0,2}	D1 ^{+0,1 -0,1}	L ^{0 -0,1}
5	10	9	7
6	10	11	7
8	12	13	8
10	15	16	9
13	15	19	9
16	15	22	9
20	15	27	10

Forma de pedido: RPPC + D
How to order: RPPC + D

PORTA PUNZÓN PARA CUELLO BOTELLA RPPB BOTTLE-NECK PUNCH RETAINER RPPB



i Para punzones RPSB, RPSC, RPBX y RPXC sin antiguo
For RPSB, RPSC, RPBX and RPXC punches without locating device

i Se suministra con sufridera incluida
It comes with its backing plate

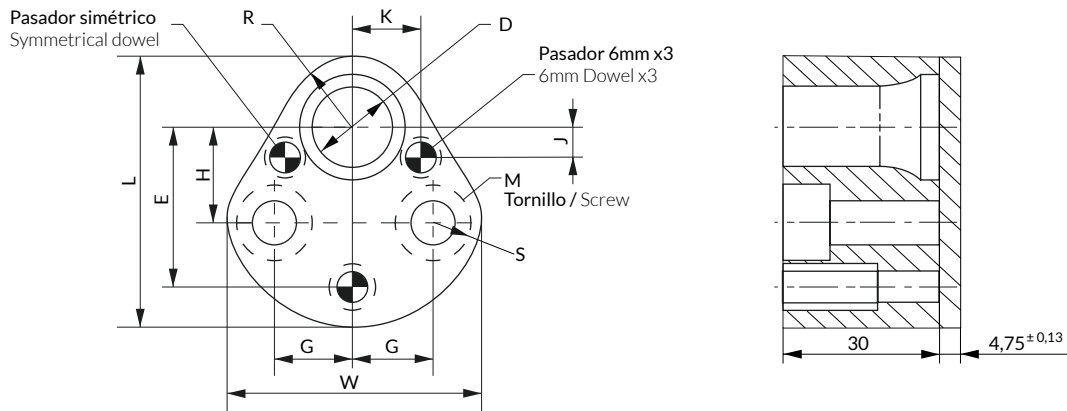

D ^{G5}	L	W	R	E $\pm 0,01$	H	G	J $\pm 0,01$	K $\pm 0,01$	S	M
10	44,5	43,7	9,5	26,925	19	11,1	7,5	9	12	M8
13	50,8	50	12,7	29,97	19	14,27	6,5	12	15,2	M8
16	54	53,2	14,3	31,75	19	15,87	6	13,5	16,8	M8
20	60,3	59,5	17,5	33,53	19	17,47	5	16,5	20	M10

Forma de pedido: RPPB + D
How to order: RPPB + D

PORTA PUNZÓN PARA CUELLO BOTELLA RPPBA BOTTLE-NECK PUNCH RETAINER RPPBA



i Para punzones RPS_ y RPX_ con antigiro
For RPS_ and RPX_ punches with locating device

i Se suministra con sufridera incluida
It comes with its backing plate

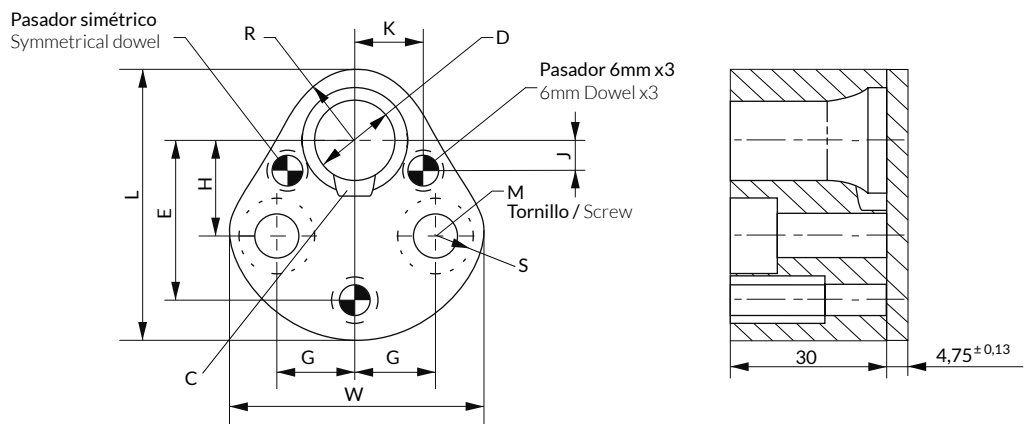

i Montaje con chaveta DIN 6885
Assembly with DIN 6885 Key

D ^{G5}	L	W	R	E $\pm 0,01$	H	G	J $\pm 0,01$	K $\pm 0,01$	S	C	M
10	44,5	43,7	9,5	26,92	19	11,12	7,5	9	12	5x5x9	M8
13	50,8	50	12,7	29,97	19	14,27	6,5	12	15,2	5x5x9	M8
16	54	53,2	14,3	31,75	19	15,87	6	13,5	16,8	5x5x9	M8
20	60,3	59,5	17,5	33,53	19	17,47	5	16,5	20	5x5x13	M10

Forma de pedido: RFPA + D
How to order: RFPA + D

PUNZÓN CABEZA CILÍNDRICA, EN BRUTO RPAB CYLINDRICAL HEAD PUNCH, BLANK RPAB

Material: 1.3343 HSS

Dureza cuerpo / Body hardness: 64 ±2HRC

Dureza cabeza / Head hardness: 50 ±5HRC

STOCK



i También disponible en otros aceros y medidas bajo plano.
Also available in other steels and dimensions per dwg.

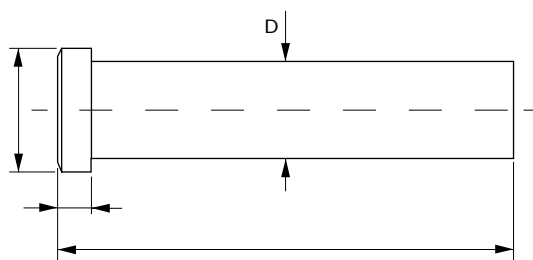

Norma / Standard: ISO 8020 A

D _{m5}	Cabeza / Head		L ^{+0,5} ₀						
	K ^{+0,25} ₀	DK ⁰ _{-0,25}	63	71	80	90	100	110	125
2	3	4	•	•	•	•	•	•	•
3	3	5	•	•	•	•	•	•	•
4	3	6	•	•	•	•	•	•	•
5	5	8	•	•	•	•	•	•	•
6	5	9	•	•	•	•	•	•	•
8	5	11	•	•	•	•	•	•	•
10	5	13	•	•	•	•	•	•	•
13	5	16	•	•	•	•	•	•	•
16	5	19	•	•	•	•	•	•	•
20	5	23	•	•	•	•	•	•	•
25	5	28	•	•	•	•	•	•	•
32	5	35	•	•	•	•	•	•	•

Forma de pedido / How to order:

Indicar / Specify	RPAB	D	L	Mat.
Ejemplo / Example	RPAB	10	71	HSS
Ejemplo / Example	RPAB	16	80	HSS

PUNZÓN CABEZA CILÍNDRICA, MECHADO RPA_ CYLINDRICAL HEAD PUNCH, STEPPED RPA_

Material: 1.3343 HSS

Dureza cuerpo / Body hardness: 64 ±2HRC

Dureza cabeza / Head hardness: 50 ±5HRC

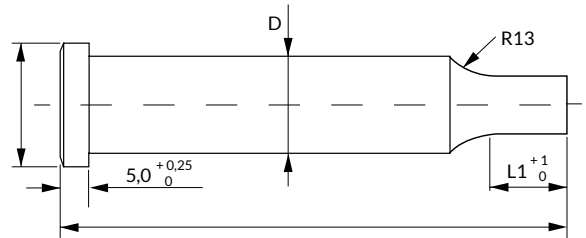

i También disponible en otros aceros y medidas bajo plano.
Also available in other steels and dimensions per dwg.

i Opciones de recubrimiento en pág. 81.
See page 81 for coating options.

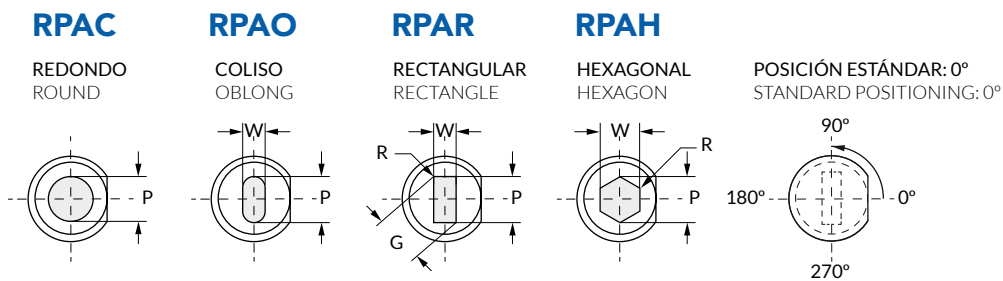

i Indicar anti giro (AG_) en pedido. Ver anti giros (pág 75)
Specify locating device type (AG_) in your order. See locating device section (page 75)

Norma / Standard: ISO 8020 B

D ^{m5}	Redondo / Round	Forma / Shape		Cabeza / Head	L ^{+0,5} ₀							L1	
	P	Min W	Max G/P	DK ⁰ _{0,25}	63	71	80	90	100	110	125	Estándar / Standard	Max.
5	1,60 - 4,99	1,6	5	8	•	•	•	•	•	•	•	13	19
6	1,6 - 4,99	1,6	6	9	•	•	•	•	•	•	•	13	19
8	1,6 - 5,99	2,5	8	11	•	•	•	•	•	•	•	19	25
10	2,5 - 7,99	3,2	10	13	•	•	•	•	•	•	•	19	25
13	3,2 - 9,99	4,5	13	16	•	•	•	•	•	•	•	19	25
16	5 - 12,99	6	16	19	•	•	•	•	•	•	•	19	25
20	10 - 19,99	8	20	23	•	•	•	•	•	•	•	19	25
25	12 - 24,99	9	25	28	•	•	•	•	•	•	•	19	25
32	16 - 31,99	10	32	35	•	•	•	•	•	•	•	25	30
40	30 - 39,99	14	40	43	-	-	•	•	•	•	•	25	30
45	25 - 44,99	10	44,99	48	-	-	•	•	•	•	•	25	30
50	30 - 49,99	12	49,99	53	-	-	•	•	•	•	•	25	30
56	35 - 55,99	13	55,99	59	-	-	•	•	•	•	•	25	30
63	40,00 - 62,99	14	62,99	66	-	-	•	•	•	•	•	25	30

Forma de pedido / How to order:

Indicar / Specify	RPA_	D	L	Mat.	P o PxW	L1	AG_
Ejemplo / Example	RPAC	8	71	HSS	P3,0	L1=20	AG1
Ejemplo / Example	RPAO	13	80	HSS	P12,0W6,0	L1=17	AG2

PUNZÓN CABEZA CILÍNDRICA CON EXPULSOR, EN BRUTO RPBB CYLINDRICAL HEAD PUNCH WITH EJECTOR, BLANK RPBB

Material: 1.3343 HSS

Dureza cuerpo / Body hardness: 64 ±2HRC

Dureza cabeza / Head hardness: 50 ±5HRC

STOCK



i También disponible en otros aceros y medidas bajo plano.
Also available in other steels and dimensions per dwg.

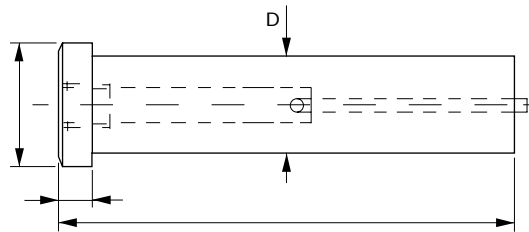

Norma / Standard: ISO 8020 E

D ^{m5}	Cabeza / Head		L ^{+0,5} ₀						
	K ^{+0,25} ₀	DK ⁰ _{-0,25}	63	71	80	90	100	110	125
5	5	8	•	•	•	•	•	•	•
6	5	9	•	•	•	•	•	•	•
8	5	11	•	•	•	•	•	•	•
10	5	13	•	•	•	•	•	•	•
13	5	16	•	•	•	•	•	•	•
16	5	19	•	•	•	•	•	•	•
20	5	23	•	•	•	•	•	•	•
25	5	28	•	•	•	•	•	•	•
32	5	35	•	•	•	•	•	•	•

Forma de pedido / How to order:

Indicar / Specify	RPBB	D	L	Mat.
Ejemplo / Example	RPBB	10	71	HSS
Ejemplo / Example	RPBB	16	80	HSS

PUNZÓN CABEZA CILÍNDRICA CON EXPULSOR, MECHADO RPB_ CYLINDRICAL HEAD PUNCH WITH EJECTOR, STEPPED RPB_

Material: 1.3343 HSS

Dureza cuerpo / Body hardness: 64 ±2HRC

Dureza cabeza / Head hardness: 50 ±5HRC

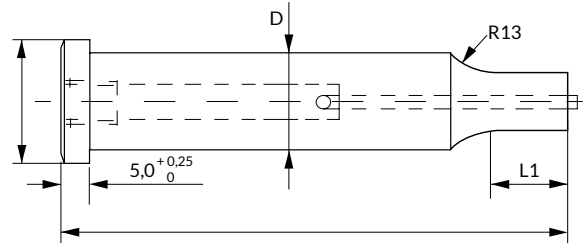

i También disponible en otros aceros y medidas bajo plano.
Also available in other steels and dimensions per dwg.

i Opciones de recubrimiento en pág. 81.
See page 81 for coating options.

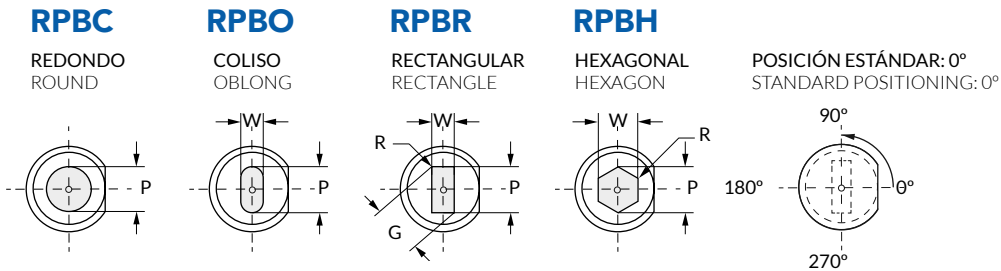

i Indicar anti giro (AG_) en pedido. Ver anti giros (pág 75)
Specify locating device type (AG_) in your order. See locating device section (page 75)

Norma / Standard: ISO 8020 F

D m ⁵	Redondo / Round	Forma / Shape		Cabeza / Head	L ^{+0.5} / ₀							L1 ⁺¹ / ₀	
	P	Min W	Max G/P	DK ⁰ / _{-0.25}	63	71	80	90	100	110	125	Estándar / Standard	Max.
5	1,60 - 4,99	1,6	5	8	•	•	•	•	•	•	•	13	19
6	2,50 - 5,99	2,5	6	9	•	•	•	•	•	•	•	13	19
8	3,20 - 7,99	3,2	8	11	•	•	•	•	•	•	•	19	25
10	4,50 - 9,99	4,5	10	13	•	•	•	•	•	•	•	19	25
13	6,00 - 12,99	6	13	16	•	•	•	•	•	•	•	19	25
16	8,00 - 15,99	7,5	16	19	•	•	•	•	•	•	•	19	25
20	10,00 - 19,99	8	20	23	•	•	•	•	•	•	•	19	25
25	12,00 - 24,99	9	25	28	•	•	•	•	•	•	•	19	25
32	16,00 - 31,99	10	32	35	•	•	•	•	•	•	•	25	30
40	30,00 - 39,99	14	40	43	-	-	•	•	•	•	•	25	30
45	25,00 - 44,99	10	44,99	48	-	-	•	•	•	•	•	25	30
50	30,00 - 49,99	12	49,99	53	-	-	•	•	•	•	•	25	30
56	35,00 - 55,99	13	55,99	59	-	-	•	•	•	•	•	25	30
63	40,00 - 62,99	14	62,99	66	-	-	•	•	•	•	•	25	30

Forma de pedido / How to order:

Indicar / Specify	RPB_	D	L	Mat.	P o PxW	L1	AG_
Ejemplo / Example	RPBC	8	71	HSS	P3,5	L1=20	AG1
Ejemplo / Example	RPBO	13	80	HSS	P12,0W6,0	L1=17	AG2

PUNZÓN CABEZA CILÍNDRICA, EN BRUTO RPAX CYLINDRICAL HEAD PUNCH, BLANK RPAX

Material: 1.3343 HSS

Dureza cuerpo / Body hardness: $64 \pm 2\text{HRC}$

Dureza cabeza / Head hardness: $50 \pm 5\text{HRC}$

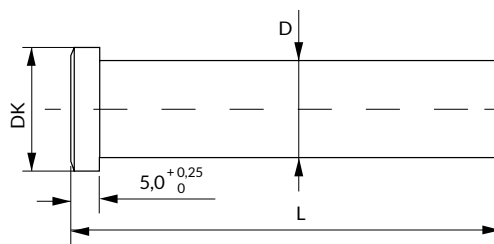

$D^{+0,1}_0$	$DK^0_{-0,25}$	$L^{+0,5}_0$						
		63	71	80	90	100	110	125
4,01-5,00	8	•	•	•	•	•	•	•
5,01-6,00	9	•	•	•	•	•	•	•
6,01-8,00	11	•	•	•	•	•	•	•
8,01-10,00	13	•	•	•	•	•	•	•
10,01-13,00	16	•	•	•	•	•	•	•
13,01-16,00	19	•	•	•	•	•	•	•
16,01-20,00	23	•	•	•	•	•	•	•
20,01-25,00	28	•	•	•	•	•	•	•

Forma de pedido / How to order:

Indicar / Specify	RPAX	D	L	Mat.
Ejemplo / Example	RPAX	10	71	HSS
Ejemplo / Example	RPAX	16	80	HSS

PUNZÓN CABEZA CILÍNDRICA CON EXPULSOR, EN BRUTO RPBX CYLINDRICAL HEAD PUNCH WITH EJECTOR, BLANK RPBX

Material: 1.3343 HSS

Dureza cuerpo / Body hardness: $64 \pm 2\text{HRC}$

Dureza cabeza / Head hardness: $50 \pm 5\text{HRC}$



i También disponible en otros aceros y medidas bajo plano.
Also available in other steels and dimensions per dwg.

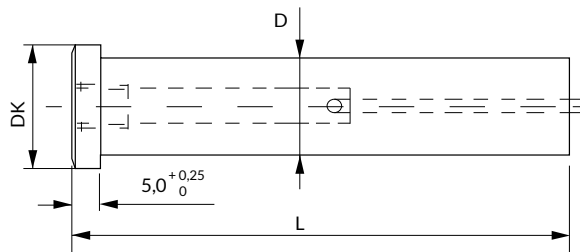

D $^{+0.1}_0$	DK $^0_{-0.25}$	L $^{+0.5}_0$							
		63	71	80	90	100	110	125	
4,01-5,00	8	•	•	•	•	•	•	•	
5,01-6,00	9	•	•	•	•	•	•	•	
6,01-8,00	11	•	•	•	•	•	•	•	
8,01-10,00	13	•	•	•	•	•	•	•	
10,01-13,00	16	•	•	•	•	•	•	•	
13,01-16,00	19	•	•	•	•	•	•	•	
16,01-20,00	23	•	•	•	•	•	•	•	
20,01-25,00	28	•	•	•	•	•	•	•	

Forma de pedido / How to order:

Indicar / Specify	RPBX	D	L	Mat.
Ejemplo / Example	RPBX	10	71	HSS
Ejemplo / Example	RPAX	16	80	HSS

PORTA PUNZÓN PARA CABEZA CILÍNDRICA RPPI RETAINER FOR CYLINDRICAL HEAD RPPI

STOCK



i Para punzones redondos RPAB, RPAX, RPBB y RPBX
For round punches RPAB, RPAX, RPBB and RPBX

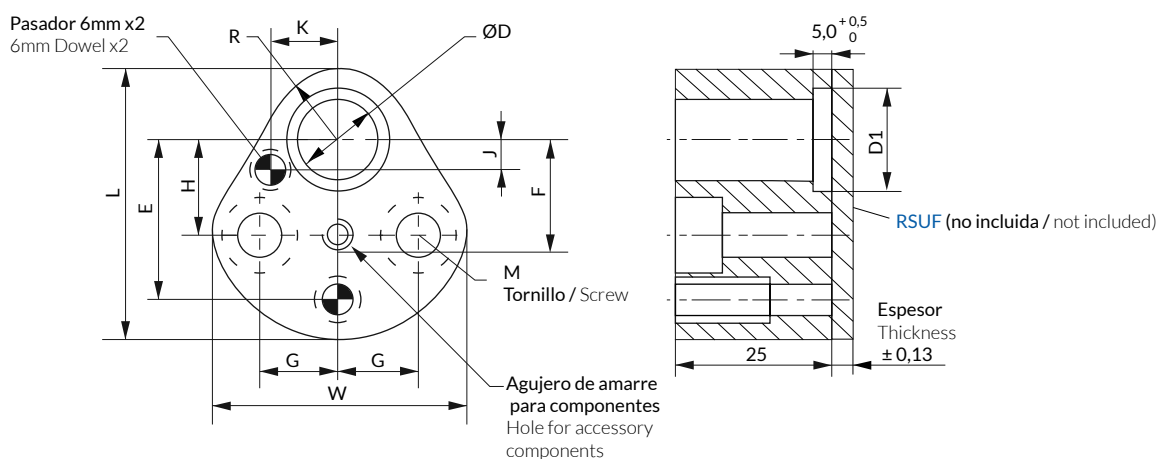

i Para solicitar sufridera Indicar **RSUF + Espesor** en pedido
To order backing plate specify **RSUF + Thickness** in your order

Espeor Disponible / Available Thickness

4,75

6,35

D	D1	L	W	R	H	J $\pm 0,01$	K $\pm 0,01$	G	E $\pm 0,01$	F	M
10	14,0	44,5	39,9	9,5	19,05	7,50	9,00	11,12	26,924	16,00	M8
13	17,0	50,8	48,3	12,7	19,05	6,50	12,00	14,27	29,972	16,00	M8
16	20,0	54,0	51,6	14,3	19,05	6,00	13,50	15,87	31,750	16,00	M8
20	24,0	60,3	58,2	17,5	19,05	5,00	16,50	17,47	33,528	23,00	M10
25	29,0	69,9	66,5	22,2	23,82	7,00	22,00	19,84	40,640	30,00	M12
32	36,0	69,9	66,5	22,2	23,82	7,00	22,00	19,84	40,640	30,00	M12

Forma de pedido: RPPI + D
How to order: RPPI + D

PORTA PUNZÓN PARA CABEZA CILÍNDRICA RPPIA RETAINER FOR CYLINDRICAL HEAD RPPIA

STOCK



i Para punzones RPA_ y RPB_ con antigiro
For RPA_ and RPB_ punches with locating device

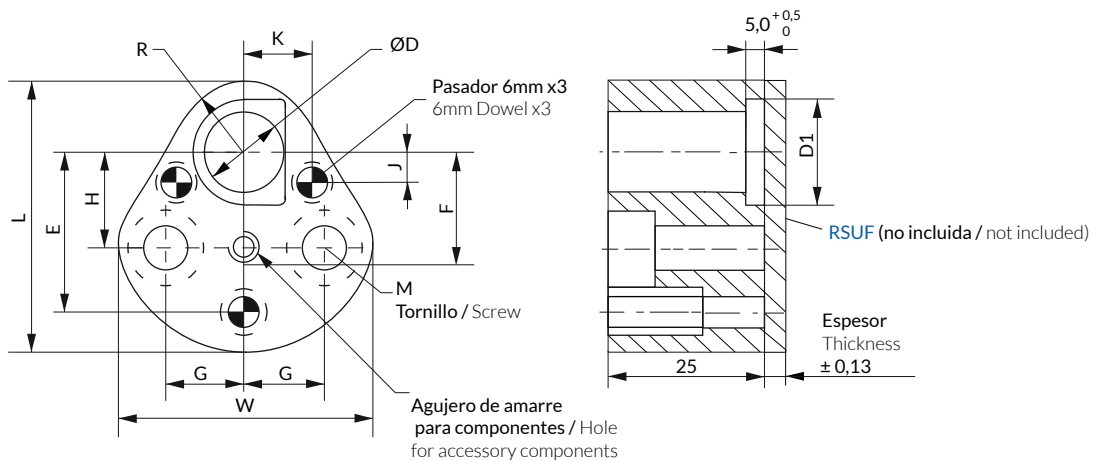

i Para solicitar sufridera Indicar RSUF + Espesor en pedido
To order backing plate specify RSUF + Thickness in your order

Esesor Disponible / Available Thickness

4,75

6,35

D	D1	L	W	R	H	J $\pm 0,01$	K $\pm 0,01$	G	E $\pm 0,01$	F	M
10	14	44,5	39,9	9,5	19,05	7,50	9,00	11,12	26,924	16,00	M8
13	17	50,8	48,3	12,7	19,05	6,50	12,00	14,27	29,972	16,00	M8
16	20	54,0	51,6	14,3	19,05	6,00	13,50	15,87	31,750	16,00	M8
20	24	60,3	58,2	17,5	19,05	5,00	16,50	17,47	33,528	23,00	M10
25	29	69,9	66,5	22,2	23,82	7,00	22,00	19,84	40,640	30,00	M12
32	36	69,9	66,5	22,2	23,82	7,00	22,00	19,84	40,640	30,00	M12

Forma de pedido: RPPIA + D
How to order: RPPIA + D

PORTA PUNZÓN PARA CABEZA CILÍNDRICA RPPF RETAINER FOR CYLINDRICAL HEAD RPPF

STOCK



i Para punzones **RPAB**, **RPAC**, **RPBB** y **RPBC** sin antigiros
For **RPAB**, **RPAC**, **RPBB** and **RPBC** punches without locating device.

i Se suministra con sufridera incluida
It comes with its backing plate

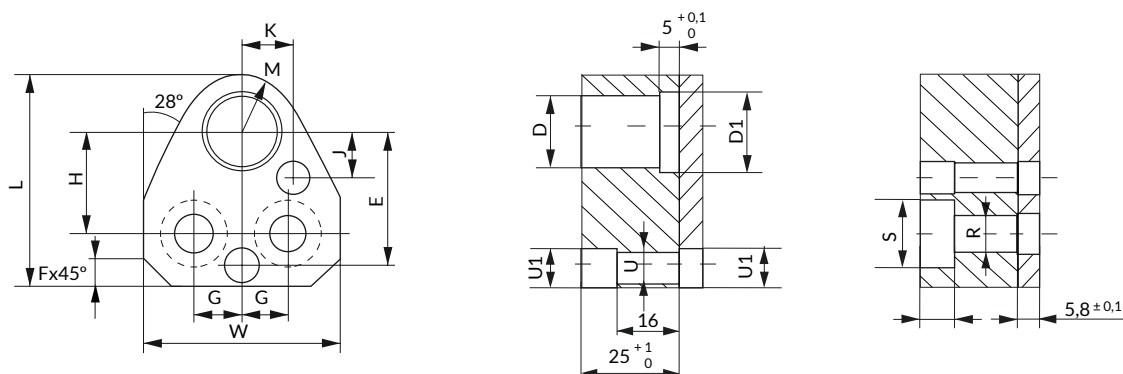

D ^{G6}	L ^{±0,25}	W ^{±0,25}	R ^{±0,25}	F ^{±0,25}	G ^{±0,1}	H ^{±0,1}	E ^{±0,1}	M H13	S H13	T ^{±0,25}	U ^{G6}	U1 ^{H13}	K ^{±0,01}	J ^{±0,01}	D1
8	44,5	38	9,5	5	10	21	29	9	16	9	6	7	10	9	12
10	44,5	38	9,5	5	10	21	29	9	16	9	6	7	10	9	14
13	50,5	47	12,5	6,5	13	23	32	9	16	9	6	7	13	11	17
16	53,5	50	14	7	12	26	34	11	18	11	6	7	13	12	20
20	60	55	17,5	8	14	27	34	11	18	11	8	9	17	11,5	25
25	69,5	63	22	9	15	30	39	14	20	20	8	9	21	12	30
32	69,5	63	22	9	15	33	40	14	20	20	8	9	22	16,5	37
40	78,5	63	26	9	15	36	43	14	20	20	8	9	25	19,5	45

Forma de pedido: RPPF + D
How to order: RPPF + D

PORTA PUNZÓN PARA CABEZA CILÍNDRICA RPPFA RETAINER FOR CYLINDRICAL HEAD RPPFA

STOCK



i Para punzones RPA_ y RPB_ con antigiro
For RPA_ and RPB_ punches with locating device

i Se suministra con sufridera incluida
It comes with its backing plate

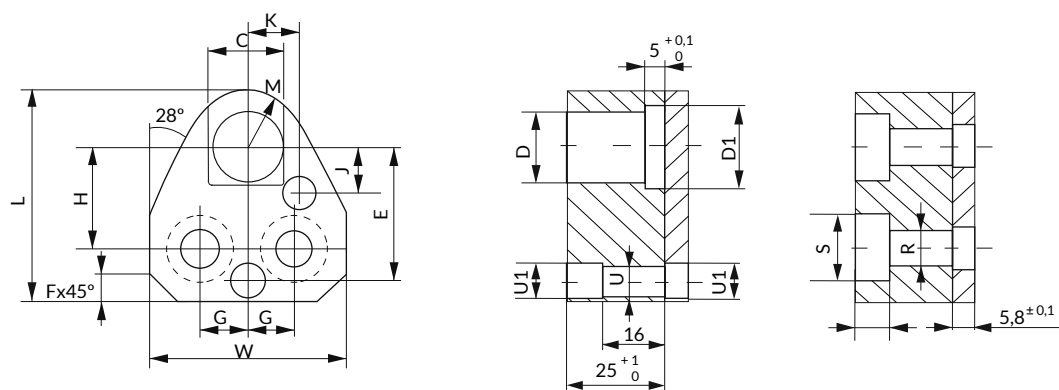

D G6	L ±0,25	W ±0,25	C ±0,25	R ±0,25	F ±0,25	G ±0,1	H ±0,1	E ±0,1	M H13	S H13	T ±0,25	U G6	U1 H13	K ±0,01	J ±0,01
8	44,5	38	12	9,5	5	10	21	29	9	16	9	6	7	10	9
10	44,5	38	12	9,5	5	10	21	29	9	16	9	6	7	10	9
13	50,5	47	17	12,5	6,5	13	23	32	9	16	9	6	7	13	11
16	53,5	50	18,5	14	7	12	26	34	11	18	11	6	7	13	12
20	60	55	23	17,5	8	14	27	34	11	18	11	8	9	17	11,5
25	69,5	63	28,5	22	9	15	30	39	14	22	20	8	9	21	12
32	69,5	63	35	22,2	9	15	33	42	14	22	20	8	9	21	20
40	78,5	63	44	26	9	15	36	43	14	22	20	8	9	25	19,5

Forma de pedido: RPPF + D
How to order: RPPF + D

PUNZÓN CABEZA REFORZADA, EN BRUTO RPVB REINFORCED HEAD PUNCH, BLANK RPVB

Material: PM4

Dureza cuerpo / Body hardness: 61 ± 1 HRC

Dureza cabeza / Head hardness: 50 ± 5 HRC

STOCK



i También disponible en otros aceros y medidas bajo plano.
Also available in other steels and dimensions per dwg.

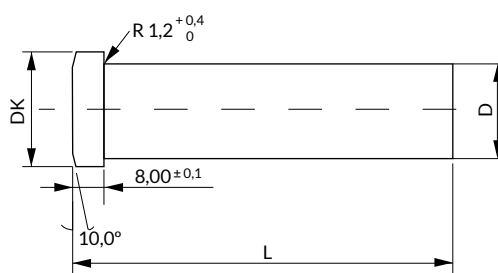

D m5	DK $^0_{-0,3}$	L $^{+0,3}_0$			
		70	80	90	100
8	13	•	•	•	•
10	15	•	•	•	•
13	18	•	•	•	•
16	21	•	•	•	•
20	25	•	•	•	•
25	30	•	•	•	•
32	37	•	•	•	•

Forma de pedido / How to order:

Indicar / Specify	RPVB	D	L	Mat.
Ejemplo / Example	RPVB	10	70	PM4
Ejemplo / Example	RPVB	16	80	PM4

PUNZÓN CABEZA REFORZADA, MECHADO RPV_ REINFORCED HEAD PUNCH, STEPPED RPV_

Material: PM4

Dureza cuerpo / Body hardness: $61 \pm 1\text{HRC}$

Dureza cabeza / Head hardness: $50 \pm 5\text{HRC}$



i También disponible en otros aceros y medidas bajo plano.
Also available in other steels and dimensions per dwg.

i Opciones de recubrimiento en pág. 81.
See page 81 for coating options.

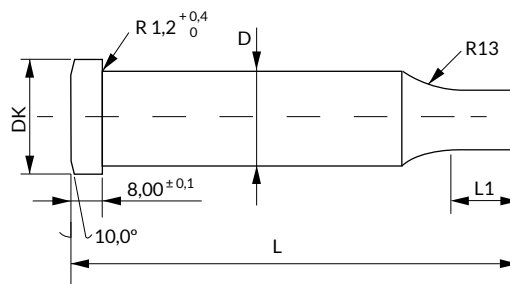

RPVC

REDONDO
ROUND

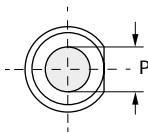

RPVO

COLISO
OBLONG

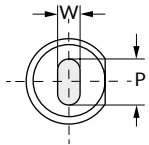

RPVR

RECTANGULAR
RECTANGLE

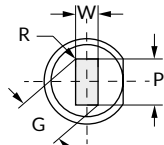

RPVH

HEXAGONAL
HEXAGON

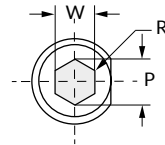

POSICIÓN ESTÁNDAR: 0°
STANDARD POSITIONING: 0°

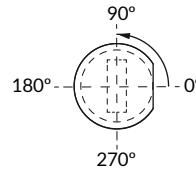

i Indicar antigiro (AG_) en pedido. Ver antigiros (pág 75)
Specify locating device type (AG_) in your order. See locating device section (page 75)

D ^{m5}	Redondo / Round	Forma / Shape		Cabeza / Head	L ^{+0,3} ₀				L1	
	P	Min W	Max G/P	DK	70	80	90	100	Estándar / Standard	Max.
8	3,1-7,99	3,1	8	13	•	•	•	•	19	25
10	3,2-9,99	3,2	10	15	•	•	•	•	19	25
13	5-12,99	4,5	13	18	•	•	•	•	19	25
16	8-15,99	6	16	21	•	•	•	•	19	25
20	10-19,99	8	20	25	•	•	•	•	19	25
25	12-24,99	9	25	30	•	•	•	•	19	25
32	16-31,99	10	32	37	•	•	•	•	25	30

Forma de pedido / How to order:

Indicar / Specify	RPV_	D	L	Mat.	P o PxW	L1	AG_
Ejemplo / Example	RPVC	8	70	PM4	P3,5	L1=20	AG1
Ejemplo / Example	RPVO	13	80	PM4	P12,0W6,0	L1=17	AG2

PUNZÓN CABEZA REFORZADA CON EXPULSOR, EN BRUTO RPZB REINFORCED HEAD PUNCH WITH EJECTOR, BLANK RPZB

Material: PM4

Dureza cuerpo / Body hardness: 61 ± 1 HRC

Dureza cabeza / Head hardness: 50 ± 5 HRC

STOCK



i También disponible en otros aceros y medidas bajo plano.
Also available in other steels and dimensions per dwg.

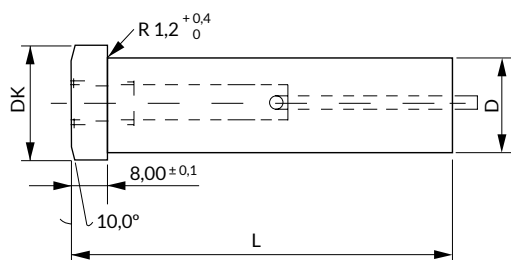

D m5	DK $^0_{-0,3}$	L $^{+0,3}_0$			
		70	80	90	100
8	13	•	•	•	•
10	15	•	•	•	•
13	18	•	•	•	•
16	21	•	•	•	•
20	25	•	•	•	•
25	30	•	•	•	•
32	37	•	•	•	•

Forma de pedido / How to order:

Indicar / Specify	RPZB	D	L	Mat.
Ejemplo / Example	RPZB	10	70	PM4
Ejemplo / Example	RPZB	16	80	PM4

PUNZÓN CABEZA REFORZADA CON EXPULSOR, MECHADO RPZ_ REINFORCED HEAD PUNCH WITH EJECTOR, STEPPED RPZ_

Material: PM4

Dureza cuerpo / Body hardness: 61 ±1HRC

Dureza cabeza / Head hardness: 50 ±5HRC



i También disponible en otros aceros y medidas bajo plano.
Also available in other steels and dimensions per dwg.

i Opciones de recubrimiento en pág. 81.
See page 81 for coating options.

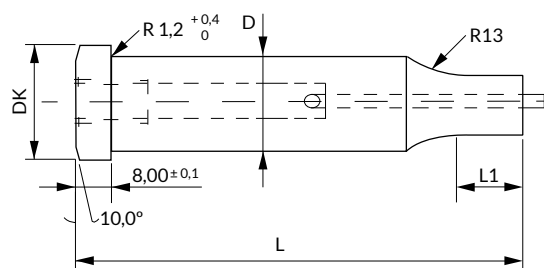

RPZC

REDONDO
ROUND

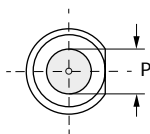

RPZO

COLISO
OBLONG

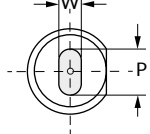

RPZR

RECTANGULAR
RECTANGLE

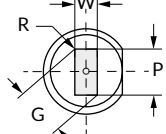

RPZH

HEXAGONAL
HEXAGON

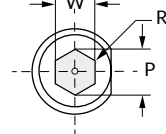

POSICIÓN ESTÁNDAR: 0°
STANDARD POSITIONING: 0°

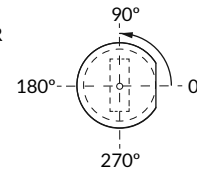

i Indicar antiguo (AG_) en pedido. Ver antiguos (pág 75)
Specify locating device type (AG_) in your order. See locating device section (page 75)

D m ⁵	DK ⁰ _{-0,3}	Redondo / Round	Forma / Shape		L ^{+0,3} ₀				L1	
		P	Min W	Max G/P	70	80	90	100	Estándar / Standard	Max.
8	13	4-7,99	4	8	•	•	•	•	19	25
10	15	4,5-9,99	4,5	10	•	•	•	•	19	25
13	18	6-12,99	6	13	•	•	•	•	19	25
16	21	8-15,99	7,5	16	•	•	•	•	19	25
20	25	10-19,99	8	20	•	•	•	•	19	25
25	30	12-24,99	9	25	•	•	•	•	19	25
32	37	16-31,99	10	32	•	•	•	•	25	30

Forma de pedido / How to order:

Indicar / Specify	RPZ_	D	L	Mat.	P o PxW	L1	AG_
Ejemplo / Example	RPZC	8	70	PM4	P5,0	L1=20	AG1
Ejemplo / Example	RPZO	13	80	PM4	P12,0 W6,0	L1=17	AG2

PORTA PUNZÓN PARA CABEZA REFORZADA RPPX RETAINER FOR REINFORCED HEAD RPPX

STOCK



i Para punzones RPVB, RPVC, RPZB y RPZC sin anti giro
For RPVB, RPVC, RPZB and RPZC punches without locating device

i Se suministra con sufridera incluida
It comes with its backing plate

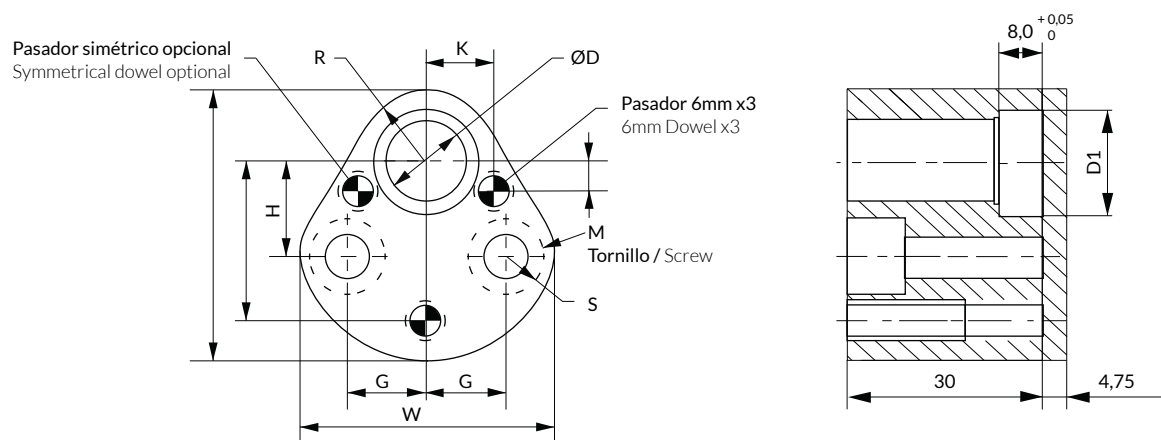

D	D1	L	W	R	H $\pm 0,13$	J $\pm 0,01$	K $\pm 0,01$	S	G $\pm 0,13$	E $\pm 0,01$	M
10	15,5	44,5	39,9	9,5	19,05	7,5	9	12	11,12	26,924	M8
13	18,5	50,8	48,3	12,7	19,05	6,5	12	15,2	14,27	29,972	M8
16	21,5	54	51,6	14,3	19,05	6	13,5	16,8	15,87	31,750	M8
20	25,5	60,3	58,2	17,5	19,05	5	16,5	20	17,47	33,528	M10
25	30,5	69,9	66,5	22,2	23,82	7	22	24,7	19,84	40,640	M12

Forma de pedido: RPPX + D
How to order: RPPX + D

PORTA PUNZÓN PARA CABEZA REFORZADA RPPXA RETAINER FOR REINFORCED HEAD RPPXA

STOCK



i Para punzones **RPV_** y **RPZ_** con antiguo.
For **RPV_** and **RPZ_** punches with locating device.

i Se suministra con sufridera incluida.
It comes with its backing plate.

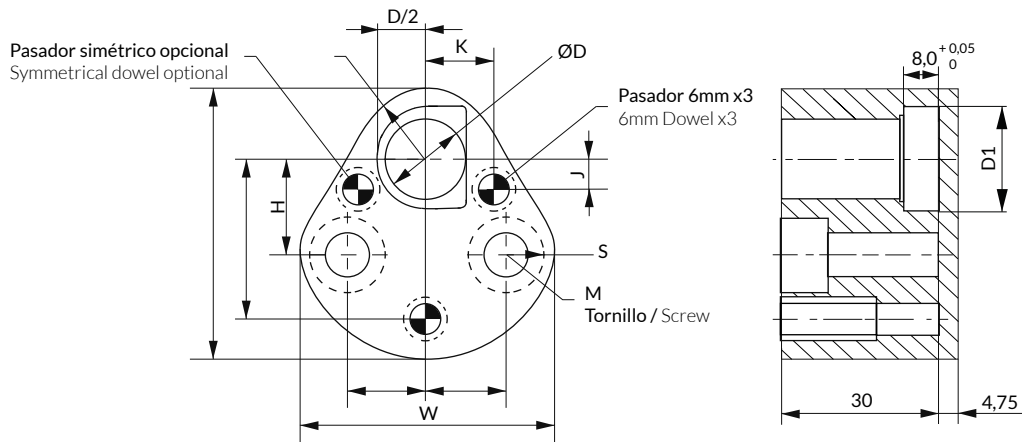

D	D1	L	W	R	H $\pm 0,13$	J $\pm 0,01$	K $\pm 0,01$	S	G $\pm 0,13$	E $\pm 0,01$	M
10	15,5	44,5	43,7	9,5	19	7,5	9	12	11,1	26,925	M8
13	18,5	50,8	50	12,7	19	6,5	12	15,2	14,3	29,97	M8
16	21,5	54	53,2	14,3	19	6	13,5	16,8	15,9	31,75	M8
20	25,5	60,3	59,5	17,5	19	5	16,5	20	17,5	33,53	M10
25	30,5	69,9	69,1	22,2	23,8	7	22	24,7	19,8	40,64	M12

Forma de pedido: RPPXA + D
How to order: RPPXA + D

PUNZÓN CAMBIO RÁPIDO CARGA FUERTE, EN BRUTO RPCB HEAVY DUTY BALL LOCK PUNCH, BLANK RPCB

Material: 1.3343 HSS
Dureza / Hardness: 64 ±2 HRC

STOCK



i También disponible en otros aceros y medidas bajo plano.
Also available in other steels and dimensions per dwg.

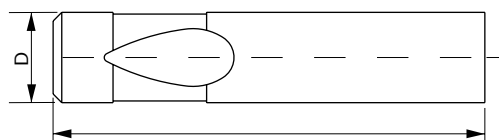

Norma / Standard: ISO 10071-2 A

D g5	L ₀ ^{+0.5}					
	71	80	90	100	110	125
10	•	•	•	•	•	•
13	•	•	•	•	•	•
16	•	•	•	•	•	•
20	•	•	•	•	•	•
25	-	•	•	•	•	•
32	-	•	•	•	•	•
40	-	•	•	•	•	•

Forma de pedido / How to order:

Indicar / Specify	RPCB	D	L	Mat.
Ejemplo / Example	RPCB	10	71	HSS
Ejemplo / Example	RPZB	16	80	HSS

PUNZÓN CAMBIO RÁPIDO CARGA FUERTE, MECHADO RPC_ HEAVY DUTY BALL LOCK PUNCH, STEPPED RPC_

Material: 1.3343 HSS
Dureza / Hardness: 64 ±2HRC



i También disponible en otros aceros y medidas bajo plano.
Also available in other steels and dimensions per dwg.

i Opciones de recubrimiento en pág. 81.
See page 81 for coating options.

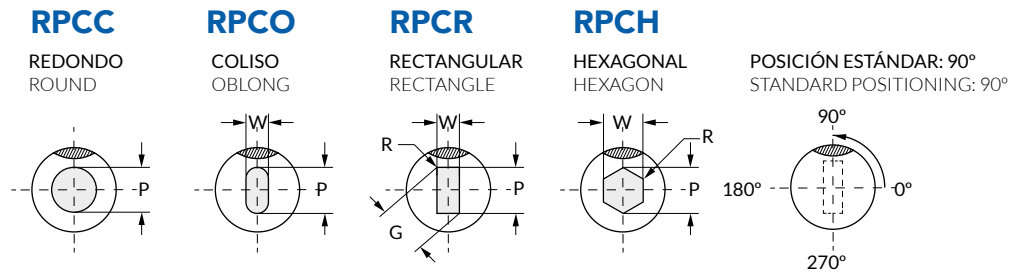
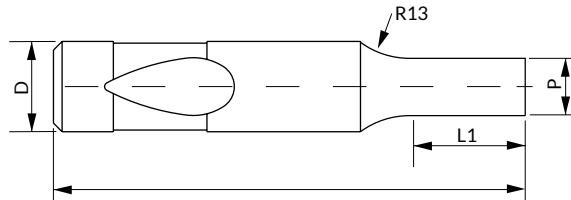

i Para un posicionamiento distinto al estándar, indicar posición deseada (B_°) en pedido.
To order alternate location, specify locating device position (B_°) in your order.

Norma / Standard: ISO 10071-2 B

D _{B5}	Redondo / Round	Forma / Shape		L ^{+0,5} ₀						L1	
	P	Min W	Max G/P	71	80	90	100	110	125	Estándar / Standard	Max.
10	2,5 - 9,98	2,50	10,00	•	•	•	•	•	•	19	25
13	5,00 - 12,98	4,50	13,00	•	•	•	•	•	•	19	25
16	8,00 - 15,98	6,00	16,00	•	•	•	•	•	•	19	25
20	12,00 - 19,98	8,00	20,00	•	•	•	•	•	•	19	25
25	16,00 - 24,98	10,00	25,00	-	•	•	•	•	•	19	25
32	24,00 - 31,98	12,00	32,00	-	•	•	•	•	•	19	25
40	30,00 - 39,98	14,00	40,00	-	•	•	•	•	•	25	30

Forma de pedido / How to order:

Indicar / Specify	RPC_	D	L	Mat.	P o PxW	L1	B°
Ejemplo / Example	RPCO	10	71	HSS	P5,0	L1=20	B45°
Ejemplo / Example	RPCO	25	80	HSS	P21,0 W11,0	L1=17	B190°

PUNZÓN CAMBIO RÁPIDO CARGA FUERTE CON EXPULSOR, EN BRUTO RPDB HEAVY DUTY EJECTOR BALL LOCK PUNCH, BLANK RPDB

Material: 1.3343 HSS

Dureza / Hardness: 64 ±2HRC

STOCK



i También disponible en otros aceros y medidas bajo plano.
Also available in other steels and dimensions per dwg.

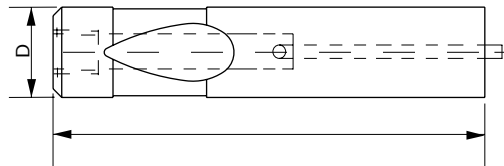

Norma / Standard: ISO 10071-2 F

D ^{h5}	L ^{+0.5} ₀						
	63	71	80	90	100	110	125
10	•	•	•	•	•	•	•
13	•	•	•	•	•	•	•
16	•	•	•	•	•	•	•
20	•	•	•	•	•	•	•
25	-	-	•	•	•	•	•
32	-	-	•	•	•	•	•
40	-	-	•	•	•	•	•

Forma de pedido / How to order:

Indicar / Specify	RPDB	D	L	Mat.
Ejemplo / Example	RPDB	10	71	HSS
Ejemplo / Example	RPDB	16	80	HSS

PUNZÓN CAMBIO RÁPIDO CARGA FUERTE CON EXPULSOR, MECHADO RPD_ HEAVY DUTY EJECTOR BALL LOCK PUNCH, STEPPED RPD_

Material: 1.3343 HSS
Dureza / Hardness: 64 ±2HRC



i También disponible en otros aceros y medidas bajo plano.
Also available in other steels and dimensions per dwg.

i Opciones de recubrimiento en pág. 81.
See page 81 for coating options.

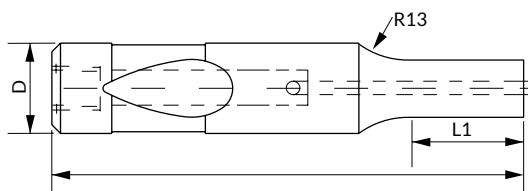

RPDC

REDONDO
ROUND

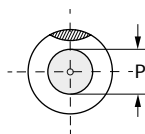

RPDO

COLISO
OBLONG

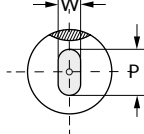

RPDR

RECTANGULAR
RECTANGLE

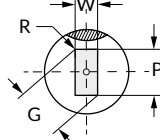

RPDH

HEXAGONAL
HEXAGON

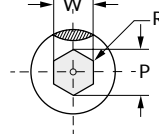

POSICIÓN ESTÁNDAR: 90°
STANDARD POSITIONING: 90°

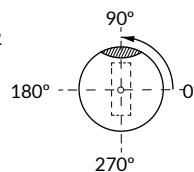

i Para un posicionamiento distinto al estándar, indicar posición deseada (B_°) en pedido.
To order alternate location, specify locating device position (B_°) in your order.

Norma / Standard: ISO 10071-2 F

D ø5	Redondo / Round	Forma / Shape		L ^{+0,5} ₀							L1	
	P	Min W	Max G/P	63	71	80	90	100	110	125	Estándar / Standard	Max.
10	2,5 - 9,98	2,50	10,00	•	•	•	•	•	•	•	19	25
13	5,00 - 12,98	4,50	13,00	•	•	•	•	•	•	•	19	25
16	8,00 - 15,98	6,00	16,00	•	•	•	•	•	•	•	19	25
20	12,00 - 19,98	8,00	20,00	•	•	•	•	•	•	•	19	25
25	16,00 - 24,98	10,00	25,00	-	-	•	•	•	•	•	19	25
32	24,00 - 31,98	12,00	32,00	-	-	•	•	•	•	•	25	25
40	30,00 - 39,98	14,00	40,00	-	-	•	•	•	•	•		30

Forma de pedido / How to order:

Indicar / Specify	RPD_	D	L	Mat.	P o PxW	L1	B°
Ejemplo / Example	RPDC	10	71	HSS	P5,0	L1=20	B45°
Ejemplo / Example	RPDO	25	80	HSS	P21,0W11,0	L1=17	B190°

PUNZÓN CAMBIO RÁPIDO CARGA FUERTE PUNTA MAYOR QUE CUERPO RPE_ HEAVY DUTY BALL LOCK PUNCH POINT LARGER THAN SHANK RPE_

Material: 1.3343 HSS
Dureza / Hardness: 64 ±2HRC



i También disponible en otros aceros y medidas bajo plano.
Also available in other steels and dimensions per dwg.

i Opciones de recubrimiento en pág. 81.
See page 81 for coating options.

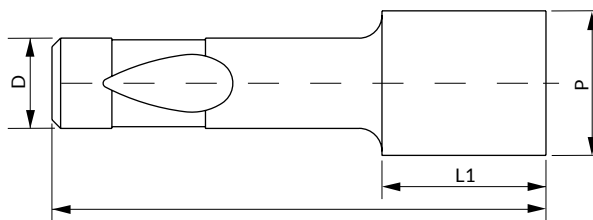

RPEC

REDONDO
ROUND

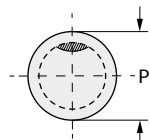

RPEO

COLISO
OBLONG

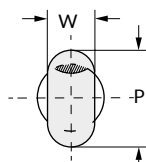

RPER

RECTANGULAR
RECTANGLE

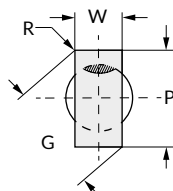

RPEH

HEXAGONAL
HEXAGON

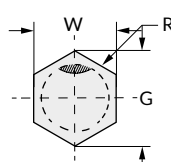

POSICIÓN ESTÁNDAR: 90°
STANDARD POSITIONING: 90°

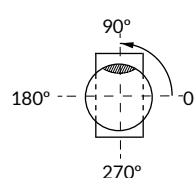

! Para un posicionamiento distinto al estándar, indicar posición deseada (B_°) en pedido.
To order alternate location, specify locating device position (B_°) in your order.

D ϵ 5	Redondo/Round	Forma / Shape		L $\begin{smallmatrix} +0,5 \\ 0 \end{smallmatrix}$			L1 $\begin{smallmatrix} +0,1 \\ 0 \end{smallmatrix}$
	P	Min W	Max G/P	80	90	100	
10	10,10 - 25,00	3,00	25,00	•	•	•	16
13	13,10 - 32,00	5,00	32,00	•	•	•	20
16	16,10 - 38,00	6,00	38,00	•	•	•	25
20	20,10 - 40,00	8,00	40,00	•	•	•	25
25	25,10 - 47,00	10,00	47,00	•	•	•	25
32	32,10 - 63,00	11,50	63,00	•	•	•	32
40	40,10 - 63,00	14,00	63,00	•	•	•	32

Forma de pedido / How to order:

Indicar / Specify	RPE_	D	L	Mat.	P o PxW	L1	B°
Ejemplo / Example	RPEC	10	80	HSS	P15,0	L1=16	B45°
Ejemplo / Example	RPEO	25	100	HSS	P41,0 W11,0	L1=25	B190°

PUNZÓN CAMBIO RÁPIDO CARGA FUERTE CON EXPULSOR

PUNTA MAYOR QUE CUERPO RPF_

HEAVY DUTY BALL LOCK PUNCH POINT LARGER THAN SHANK RPF_

Material: 1.3343 HSS
Dureza / Hardness: 64 ±2HRC



i También disponible en otros aceros y medidas bajo plano.
Also available in other steels and dimensions per dwg.

i Opciones de recubrimiento en pág. 81.
See page 81 for coating options.

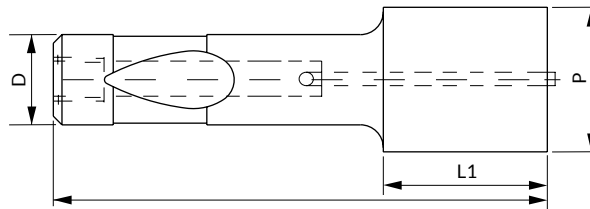

RPEC

REDONDO
ROUND

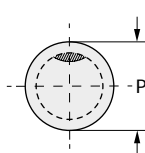

RPEO

COLISO
OBLONG

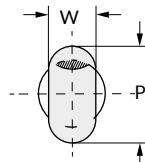

RPER

RECTANGULAR
RECTANGLE

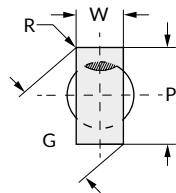

RPEH

HEXAGONAL
HEXAGON

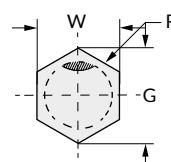

POSICIÓN ESTÁNDAR: 90°
STANDARD POSITIONING: 90°

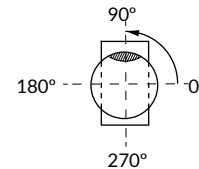

i Para un posicionamiento distinto al estándar, indicar posición deseada (B_°) en pedido.
To order alternate location, specify locating device position (B_°) in your order.

D g5	Redondo / Round	Forma / Shape		L ^{+0,5} ₀			L1 ^{+0,1} ₀
	P	Min W	Max G/P	80	90	100	
10	10,10 - 25,00	3,00	25,00	•	•	•	16
13	13,10 - 32,00	5,00	32,00	•	•	•	20
16	16,10 - 38,00	6,00	38,00	•	•	•	25
20	20,10 - 40,00	8,00	40,00	•	•	•	25
25	25,10 - 47,00	10,00	47,00	•	•	•	25
32	32,10 - 63,00	11,50	63,00	•	•	•	32
40	40,10 - 63,00	14,00	63,00	•	•	•	32

Forma de pedido / How to order:

Indicar / Specify	RPF_	D	L	Mat.	P o PxW	L1	B°
Ejemplo / Example	RPFC	10	80	HSS	P15,0	L1=16	B45°
Ejemplo / Example	RPFO	25	100	HSS	P41,0 W11,0	L1=25	B190°

PORTA PUNZÓN DE CAMBIO RÁPIDO PARA CARGA FUERTE RPPH

HEAVY DUTY BALL LOCK PUNCH RETAINER RPPH

STOCK



i Para punzones de cambio rápido [RPCB](#), [RPC_](#), [RPDB](#), [RPD_](#), [RPE_](#) y [RPF_](#)
For ball lock punches [RPCB](#), [RPC_](#), [RPDB](#), [RPD_](#), [RPE_](#) and [RPF_](#)

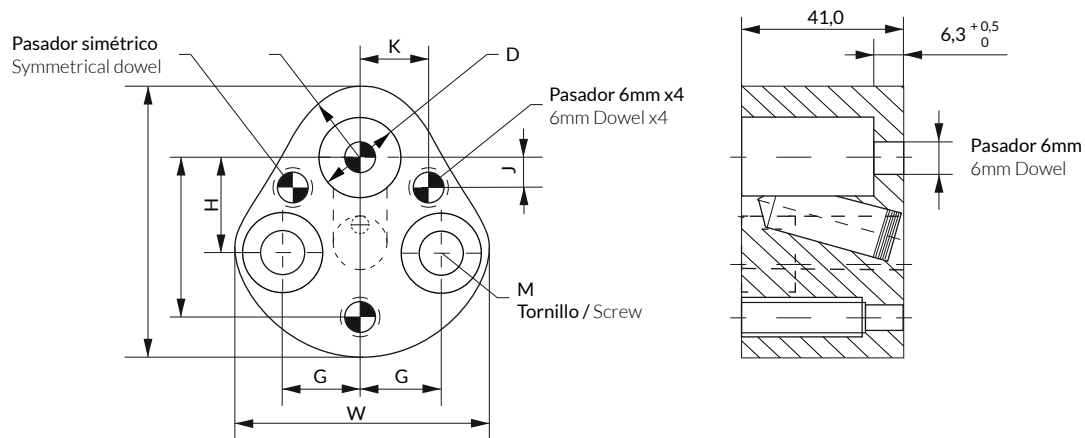

D	E ±0,01	G	L	W	R	H	J ±0,01	K ±0,01	M
10	26,924	11,12	44,5	39,9	9,5	19,05	7,5	9	M8
13	26,972	14,27	50,8	48,3	12,7	19,05	6,5	12	M8
16	31,75	15,87	54	51,6	14,3	19,05	6	13,5	M8
20	33,528	17,47	60,3	58,2	17,5	19,05	5	16,5	M10
25	40,64	19,84	69,9	66,5	22,2	23,82	7	22	M12
32	40,64	19,84	69,9	66,5	22,2	23,82	7	22	M12
40	43,993	24	77,4	77,8	26	27	10	26	M12

Forma de pedido: RPPH*D
How to order: RPPH*D

PORTA PUNZÓN DE CAMBIO RÁPIDO PARA CARGA FUERTE RPPR HEAVY DUTY BALL LOCK PUNCH RETAINER RPPR



i Para punzones de cambio rápido RPVC y RPZC
For ball lock punches RPVC and RPZC

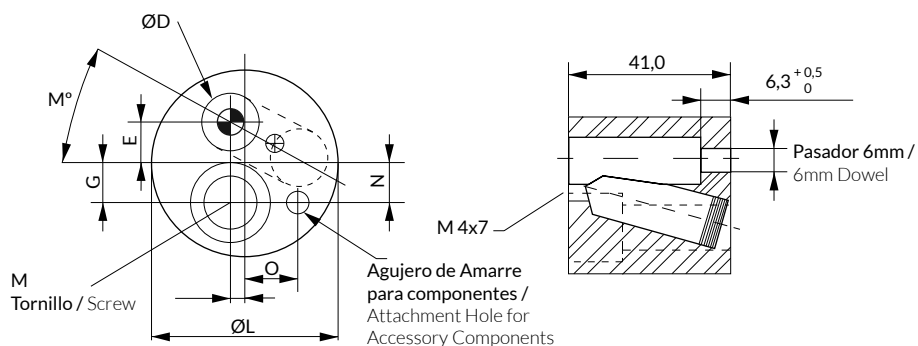

ØD	ØL	E	G	K	M	N	O	M	Agujero de amarre para componentes Attachment Hole for Components
10	38,1	9,86	7,1	2,65	20,5°	4,47	12,72	M12	M6 x 1,0
13	41,3	9,25	9,17	3,18	26°	9,35	11,88	M12	M6 x 1,0
16	44,5	9,1	11,07	1,93	33,5°	10,21	13,16	M12	M6 x 1,0
20	57,2	12,2	14,3	0	30°	9,35	19,4	M16	M8 x 1,25
25	63,5	12,51	17,5	0	30°	14,27	20,17	M16	M8 x 1,25
32	76,2	15,67	20,83	0	30°	15,46	26,12	M20	M8 x 1,25
40	82,6	15,39	23,55	0	30°	15,46	26,12	M20	M8 x 1,25

Forma de pedido: RPPR*D
How to order: RPPR*D

MATRIZ LISA RMSA HEADLESS MATRIX RMSA

Material: 1.2379 HWS
Dureza / Hardness: 62 ±2HRC

Material: 1.3343 HSS
Dureza / Hardness: 64 ±2HRC

STOCK



i También disponible en otros aceros y medidas bajo plano.
Also available in other steels and dimensions per dwg.

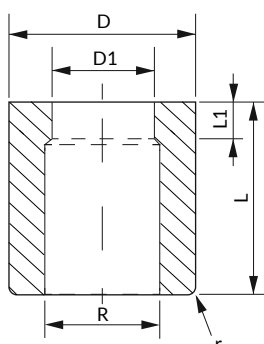

Norma / Standard: DIN 9845 A

D1 ^{H8}	L ^{+0,3} ₀		D ⁿ⁶	R ±0,1	L1	r
1	20	28	5	D1+0,3	2	0,3
1,1 - 2	20	28	6	D1+0,3	3	0,3
2,1 - 3	20	28	7	D1+0,5	3	0,4
3,1 - 4	20	28	8	D1+0,5	3	0,4
4,1 - 5	20	28	10	D1+0,7	4	0,4
5,1 - 6	20	28	12	D1+0,7	4	0,6
6,1 - 8	20	28	15	D1+0,7	4	0,8
8,1 - 10	20	28	18	D1+1	4	0,8
10,1 - 12	20	28	22	D1+1	5	0,8
12,1 - 15	20	28	26	D1+1	5	0,8

Forma de pedido / How to order:

Indicar / Specify	RMSA	D1	L	Mat.
Ejemplo / Example	RMSA	10	20	HSS
Ejemplo / Example	RMSA	5	28	HWS

MATRIZ CON VALONA RMSB HEADED MATRIX RMSB

Material: 1.2379 HWS
Dureza / Hardness: 62 ±2HRC

Material: 1.3343 HSS
Dureza / Hardness: 64 ±2HRC

STOCK



i También disponible en otros aceros y medidas bajo plano.
Also available in other steels and dimensions per dwg.

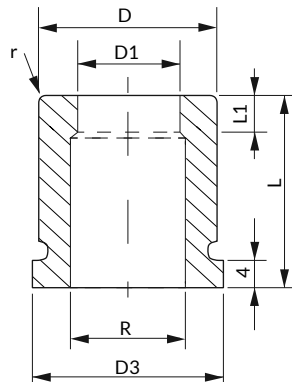

Norma / Standard: DIN 9845 B

D1H8	L $\begin{smallmatrix} +0,3 \\ 0 \end{smallmatrix}$		D k6	D3	R ±0,1	L1	r
1	20	28	5	7	D1+0,3	2	0,3
1,1 - 2	20	28	6	8	D1+0,3	3	0,3
2,1 - 3	20	28	7	9	D1+0,5	3	0,4
3,1 - 4	20	28	8	10	D1+0,5	3	0,4
4,1 - 5	20	28	10	12	D1+0,7	4	0,4
5,1 - 6	20	28	12	14	D1+0,7	4	0,6
6,1 - 8	20	28	15	17	D1+0,7	4	0,8
8,1 - 10	20	28	18	20	D1+1	4	0,8
10,1 - 12	20	28	22	24	D1+1	5	0,8
12,1 - 15	20	28	26	28	D1+1	5	0,8

Forma de pedido / How to order:

Indicar / Specify	RMSB	D1	L	Mat.
Ejemplo / Example	RMSB	10	20	HSS
Ejemplo / Example	RMSB	5	28	HWS

MATRIZ LISA SALIDA RECTA, EN BRUTO RMAB HEADLESS MATRIX COUNTERBORE RELIEF, BLANK RMAB

Material: 1.2379 HWS
Dureza / Hardness: 62 ±2HRC

STOCK



i También disponible en otros aceros y medidas bajo plano.
Also available in other steels and dimensions per dwg.

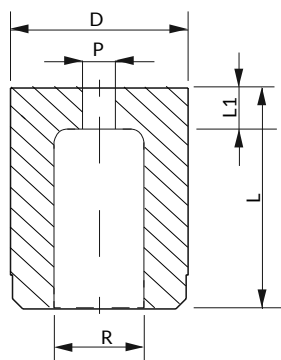

Norma / Standard: ISO 8977 C

D	n5	L 1	$\begin{matrix} +1,5 \\ 0 \end{matrix}$	R	P	$L \begin{matrix} +0,5 \\ 0 \end{matrix}$							
						20	22	25	28	30	32	35	40
8		4		4	1,2	•	•	•	•	•	•	•	•
10		4		6,0	1,2	•	•	•	•	•	•	•	•
13		5		8	1,4	•	•	•	•	•	•	•	•
16		5		9,5	2	•	•	•	•	•	•	•	•
20		5		12	2,8	•	•	•	•	•	•	•	•
22		6		15	2,8	•	•	•	•	•	•	•	•
25		6		17,5	4,4	•	•	•	•	•	•	•	•
32		6		21	5,2	•	•	•	•	•	•	•	•
38		8		27	5,6	•	•	•	•	•	•	•	•
40		8		27	5,6	•	•	•	•	•	•	•	•

Forma de pedido / How to order:

Indicar / Specify	RMAB	D	L	Mat.
Ejemplo / Example	RMAB	10	20	HWS
Ejemplo / Example	RMAB	32	30	HWS

MATRIZ LISA AGUJERO PASANTE, EN BRUTO RMCB HEADLESS MATRIX THRU HOLE, BLANK RMCB

Material: 1.2379 HWS
Dureza / Hardness: 62 ±2HRC

STOCK

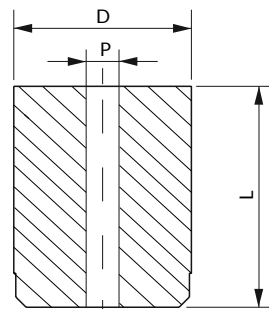

i También disponible en otros aceros y medidas bajo plano.
Also available in other steels and dimensions per dwg.

Norma / Standard: ISO 8977 E

D ⁿ⁵	P	L ^{+0.5} ₀									
		20	22	25	28	30	32	35	40		
8	1,2	•	•	•	•	•	•	•	•	•	
10	1,2	•	•	•	•	•	•	•	•	•	
13	1,4	•	•	•	•	•	•	•	•	•	
16	2	•	•	•	•	•	•	•	•	•	
20	2,4	•	•	•	•	•	•	•	•	•	
22	2,4	•	•	•	•	•	•	•	•	•	
25	2,4	•	•	•	•	•	•	•	•	•	
32	2,4	•	•	•	•	•	•	•	•	•	
38	2,4	•	•	•	•	•	•	•	•	•	
40	2,4	•	•	•	•	•	•	•	•	•	
45	2,4	•	•	•	•	•	•	•	•	•	
50	2,4	-	-	•	•	•	-	•	•	•	
56	2,4	-	-	•	•	•	-	•	•	•	
63	2,4	-	-	•	•	•	-	•	•	•	
71	2,4	-	-	•	•	•	-	•	•	•	
76	2,4	-	-	•	•	•	-	•	•	•	
85	2,4	-	-	•	•	•	-	•	•	•	
90	2,4	-	-	•	•	•	-	•	•	•	
100	2,4	-	-	•	•	•	-	•	•	•	

Forma de pedido / How to order:

Indicar / Specify	RMCB	D	L	Mat.
Ejemplo / Example	RMCB	10	20	HWS
Ejemplo / Example	RMCB	32	30	HWS

MATRIZ CON VALONA SALIDA RECTA, EN BRUTO RMBB HEADED MATRIX COUNTERBORE RELIEF, BLANK RMBB

Material: 1.2379 HWS
Dureza / Hardness: 62 ±2HRC

STOCK



i También disponible en otros aceros y medidas bajo plano.
Also available in other steels and dimensions per dwg.

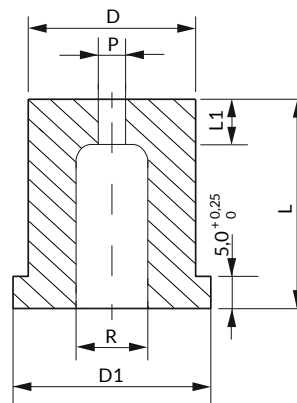

Norma / Standard: ISO 8977 D

Dm5	D1 ⁰ _{-2.5}	L1 ^{+1.5} ₀	R	P	L ^{+0.5} ₀							
					20	22	25	28	30	32	35	40
8	11	4	4	1,2	•	•	•	•	•	•	•	•
10	13	4	6,0	1,2	•	•	•	•	•	•	•	•
13	16	5	8	1,4	•	•	•	•	•	•	•	•
16	19	5	9,5	2	•	•	•	•	•	•	•	•
20	23	5	12	2,8	•	•	•	•	•	•	•	•
22	25	6	15	2,8	•	•	•	•	•	•	•	•
25	28	6	17,5	4,4	•	•	•	•	•	•	•	•
32	35	6	21	5,2	•	•	•	•	•	•	•	•
38	41	8	27	5,6	•	•	•	•	•	•	•	•
40	43	8	27	5,6	•	•	•	•	•	•	•	•

Forma de pedido / How to order:

Indicar / Specify	RMBB	D	L	Mat.
Ejemplo / Example	RMBB	10	20	HWS
Ejemplo / Example	RMBB	32	30	HWS

MATRIZ CON VALONA AGUJERO PASANTE, EN BRUTO RMDB HEADED MATRIX THRU HOLE, BLANK RMDB

Material: 1.2379 HWS
Dureza / Hardness: 62 ±2HRC

STOCK

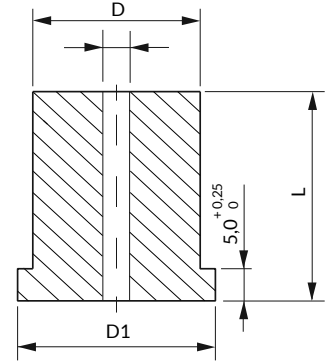

i También disponible en otros aceros y medidas bajo plano.
Also available in other steels and dimensions per dwg.

Norma / Standard: ISO 8977 F

D _{m5}	D1 _{-0,25} ⁰	P	L ₀ ^{+0,5}							
			20	22	25	28	30	32	35	40
8	11	1,2	•	•	•	•	•	•	•	•
10	13	1,2	•	•	•	•	•	•	•	•
13	16	1,4	•	•	•	•	•	•	•	•
16	19	2	•	•	•	•	•	•	•	•
20	23	2,4	•	•	•	•	•	•	•	•
22	25	2,4	•	•	•	•	•	•	•	•
25	28	2,4	•	•	•	•	•	•	•	•
32	35	2,4	•	•	•	•	•	•	•	•
38	41	2,4	•	•	•	•	•	•	•	•
40	43	2,4	•	•	•	•	•	•	•	•
45	48	2,4	•	•	•	•	•	•	•	•
50	53	2,4	-	-	•	•	•	-	•	•
56	59	2,4	-	-	•	•	•	-	•	•
63	66	2,4	-	-	•	•	•	-	•	•
71	74	2,4	-	-	•	•	•	-	•	•
76	79	2,4	-	-	•	•	•	-	•	•
85	88	2,4	-	-	•	•	•	-	•	•
90	93	2,4	-	-	•	•	•	-	•	•
100	103	2,4	-	-	•	•	•	-	•	•

Forma de pedido / How to order:

Indicar / Specify	RMDB	D	L	Mat.
Ejemplo / Example	RMDB	10	20	HWS
Ejemplo / Example	RMDB	32	30	HWS

MATRIZ LISA SALIDA RECTA, CON FORMA RMA_ HEADLESS MATRIX COUNTERBORE RELIEF, SHAPED RMA_

Material: 1.2379 HWS
Dureza / Hardness: 62 ±2HRC

i También disponible en otros aceros y medidas bajo plano.
Also available in other steels and dimensions per dwg.

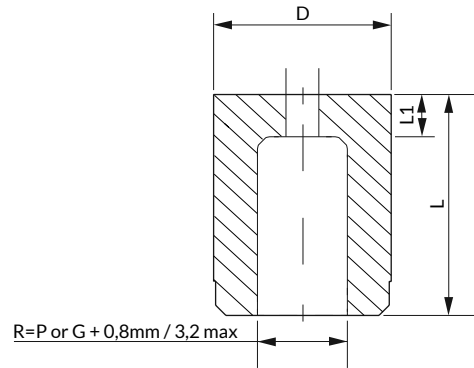

RMAC

REDONDO
ROUND

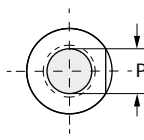

RMAO

COLISO
OBLONG

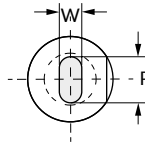

RMAR

RECTANGULAR
RECTANGLE

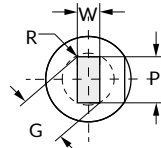

RMAH

HEXAGONAL
HEXAGON

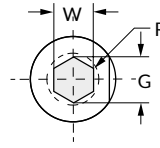

POSICIÓN ESTÁNDAR: 0°
STANDARD POSITIONING: 0°

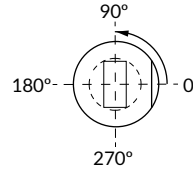

i Recomendamos montaje con bridas RBAM y RBAF
Recommended assembly with RBAM and RBAF flanges

i Indicar anti giro (AG_) en pedido. Ver anti giros (pág 76)
Specify locating device type (AG_) in your order. See locating device section (page 76)

Norma / Standard: ISO 8977 A

D ^{m5}	L1 ^{+1.5} ₀	Max R	Redondo / Round	Forma / Shape		L ^{+0.5} ₀								
			P	Min W	Max G/P	20	22	25	28	30	32	35	40	
8	4	4	1,50 - 3,20	1,5	3,2	•	•	•	•	•	•	•	•	•
10	4	6,0	1,60 - 5,00	1,6	5	•	•	•	•	•	•	•	•	•
13	5	8	1,80 - 7,20	1,8	7,2	•	•	•	•	•	•	•	•	•
16	5	9,5	5,00 - 8,80	2,5	8,8	•	•	•	•	•	•	•	•	•
20	5	12	5,50 - 11,00	3,2	11	•	•	•	•	•	•	•	•	•
22	6	15	7,50 - 14,00	4	14	•	•	•	•	•	•	•	•	•
25	6	17,5	9,50 - 16,50	4,8	16,5	•	•	•	•	•	•	•	•	•
32	6	21	13,00 - 20,00	5,5	20	•	•	•	•	•	•	•	•	•
38	8	27	16,00 - 26,00	6,4	26	•	•	•	•	•	•	•	•	•
40	8	27	16,00 - 26,00	6,4	26	•	•	•	•	•	•	•	•	•
45	8	36	17,50 - 35,00	7,5	35	-	•	•	•	•	•	•	•	•
50	8	41	20,00 - 40,00	8	40	-	•	•	•	•	•	•	•	•
56	8	46	22,50 - 45,00	9	45	-	•	•	•	•	•	•	•	•
63	8	51	25,00 - 50,00	10	50	-	•	•	•	•	•	•	•	•
71	8	57	27,50 - 56,00	11	56	-	•	•	•	•	•	•	•	•

Forma de pedido / How to order:

Indicar / Specify	RMA_	D	L	Mat.	P o PxW	AG_
Ejemplo / Example	RMAC	10	20	HWS	P4,0	AG4
Ejemplo / Example	RMAO	32	30	HWS	P15,0 W6,0	AG5

MATRIZ LISA SALIDA CÓNICA, CON FORMA RME_ HEADLESS MATRIX TAPER RELIEF, SHAPED RME_

Material: 1.2379 HWS
Dureza / Hardness: 62 ±2HRC

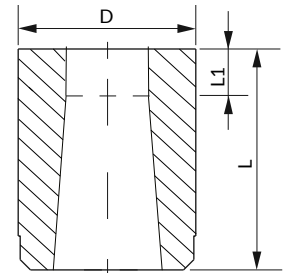

Conicidad estándar / Standard taper:
- Forma redonda / Round shape: 1°
- Otras formas / Other shapes: 1,5°

i También disponible en otros aceros y medidas bajo plano.
Also available in other steels and dimensions per dwg.

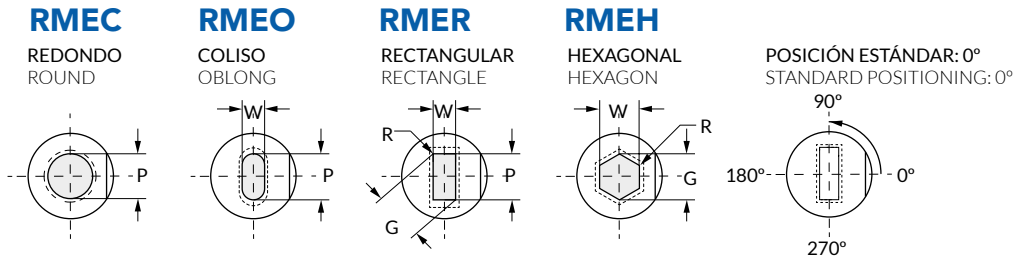

- i** Recomendamos montaje con bridas RBAM y RBAF
Recommended assembly with RBAM and RBAF flanges
- i** Indicar antigiro (AG_) en pedido. Ver antigiros (pág 76)
Specify locating device type (AG_) in your order. See locating device section (page 76)

D m5	L1 ^{+1,5} ₀	Redondo / Round		Forma / Shape		L ^{+0,5} ₀							
		P	Min W	Max G/P	20	22	25	28	30	32	35	40	
8	4	1,5 - 3,20	1,5	3,2	•	•	•	•	•	•	•	•	-
10	4	1,6 - 5,0	1,6	5	•	•	•	•	•	•	•	•	•
13	5	3,0 - 7,20	1,8	7,2	•	•	•	•	•	•	•	•	•
16	5	5,0 - 8,8	2,5	8,8	•	•	•	•	•	•	•	•	•
20	5	5,5 - 11,00	3,2	11	•	•	•	•	•	•	•	•	•
22	6	7,5 - 14,0	4	14	•	•	•	•	•	•	•	•	•
25	6	9,5 - 16,5	4,8	16,5	•	•	•	•	•	•	•	•	•
32	6	13,0 - 20,0	5,5	20	•	•	•	•	•	•	•	•	•
38	8	16,0 - 26,0	6,4	26	•	•	•	•	•	•	•	•	•
40	8	16,0 - 26,0	6,4	26	•	•	•	•	•	•	•	•	•
45	8	22,0 - 31,0	7,5	31	-	-	•	•	•	•	•	•	•
50	8	24,0 - 34,0	8	34	-	-	•	•	•	•	•	•	•
56	8	26,0 - 38,0	8,5	38	-	-	•	•	•	•	•	•	•
63	8	30,0 - 43,0	9	43	-	-	•	•	•	•	•	•	•
71	8	34,0 - 48,0	9,5	48	-	-	•	•	•	•	•	•	•
76	8	36,0 - 52,0	10	52	-	-	-	-	-	-	•	•	•
85	8	40,0 - 58,0	11	58	-	-	-	-	-	-	•	•	•
90	8	43,0 - 61,0	12	61	-	-	-	-	-	-	•	•	•
100	8	48,0 - 68,0	13	68	-	-	-	-	-	-	•	•	•

Forma de pedido / How to order:

Indicar / Specify	RME_	D	L	Mat.	P o PxW	AG_
Ejemplo / Example	RMEC	10	20	HWS	P4,0	AG4
Ejemplo / Example	RMEO	32	30	HWS	P15,0 W6,0	AG5

MATRIZ CON VALONA SALIDA RECTA, CON FORMA RMB_ HEADED MATRIX COUNTERBORE RELIEF, SHAPED RMB_

Material: 1.2379 HWS
Dureza / Hardness: 62 ±2HRC

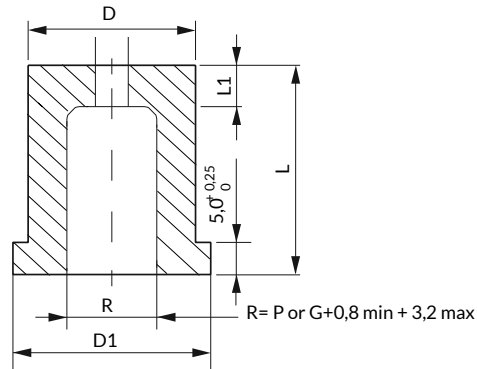

i También disponible en otros aceros y medidas bajo plano.
Also available in other steels and dimensions per dwg.

RMBC

REDONDO
ROUND

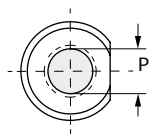

RMBO

COLISO
OBLONG

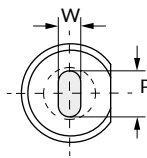

RMBR

RECTANGULAR
RECTANGLE

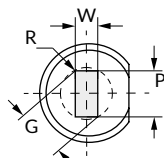

RMBH

HEXAGONAL
HEXAGON

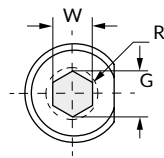

POSICIÓN ESTÁNDAR: 0°
STANDARD POSITIONING: 0°

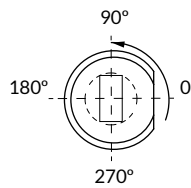

Indicar anti giro (AG_) en pedido. Ver anti giros (pág 75)
Specify locating device type (AG_) in your order. See locating device section (page 75)

Norma / Standard: ISO 8977 B

D ^{m5}	D1 ⁰ _{-2,5}	L1 ^{+1,5} ₀	Max R	Redondo / Round		Forma / Shape		L ^{+0,5} ₀							
				P	Min W	Max G/P	20	22	25	28	30	32	35	40	
8	11	4	4	1,50 - 3,20	1,5	3,2	•	•	•	•	•	•	•	•	-
10	13	4	6	1,60 - 5,00	1,6	5	•	•	•	•	•	•	•	•	•
13	16	5	8	1,80 - 7,20	1,8	7,2	•	•	•	•	•	•	•	•	•
16	19	5	9,5	5,00 - 8,00	2,5	8,8	•	•	•	•	•	•	•	•	•
20	23	5	12	5,50 - 11,00	3,2	11	•	•	•	•	•	•	•	•	•
22	25	5	15	7,50 - 14,00	4	14	•	•	•	•	•	•	•	•	•
25	28	6	17,5	9,50 - 16,50	4,8	16,5	•	•	•	•	•	•	•	•	•
32	35	6	21	13,00 - 20,00	5,5	20	•	•	•	•	•	•	•	•	•
38	41	8	27	16,00 - 26,00	6,4	26	•	•	•	•	•	•	•	•	•
40	43	8	27	16,00 - 26,00	6,5	26	•	•	•	•	•	•	•	•	•

Forma de pedido / How to order:

Indicar / Specify	RMB_	D	L	Mat.	P o PxW	AG_
Ejemplo / Example	RMBC	10	20	HWS	P4,0	AG2
Ejemplo / Example	RMBO	32	30	HWS	P15,0 W6,0	AG3

MATRIZ CON VALONA SALIDA CÓNICA, CON FORMA RMF_
HEADED MATRIX TAPER RELIEF, SHAPED RMF_

Material: 1.2379 HWS
 Dureza / Hardness: 62 ±2HRC

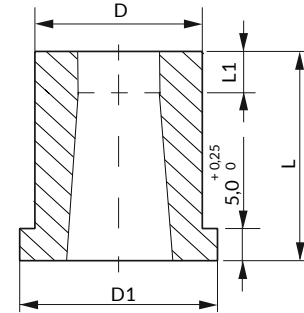

i También disponible en otros aceros y medidas bajo plano.
 Also available in other steels and dimensions per dwg.

Conicidad estándar / Standard taper:
 - Forma redonda / Round shape: 1°
 - Otras formas / Other shapes: 1,5°

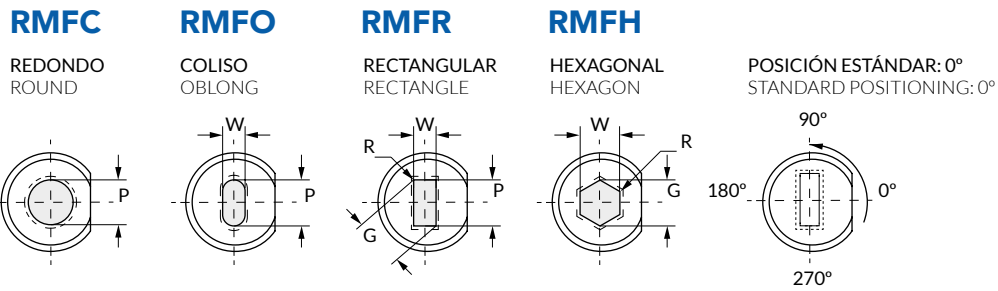

i Indicar anti giro (AG_) en pedido. Ver anti giros (pág 75)
 Specify locating device type (AG_) in your order. See locating device section (page 75)

D	D1 _{-0,25} ⁰	L1	Redondo / Round	Forma / Shape		L ₀ ^{+0,5}								
			P	Min W	Max G/P	20	22	25	28	30	32	35	40	
8	11	4	1,50 - 3,20	1,5	3,2	•	•	•	•	•	•	•	•	-
10	13	4	1,60 - 5,00	1,6	5	•	•	•	•	•	•	•	•	•
13	16	5	1,80 - 7,20	1,8	7,2	•	•	•	•	•	•	•	•	•
16	19	5	5,0 - 8,80	2,5	8,8	•	•	•	•	•	•	•	•	•
20	23	5	5,50 - 11,00	3,2	11	•	•	•	•	•	•	•	•	•
22	25	6	7,50 - 14,00	4	14	•	•	•	•	•	•	•	•	•
25	28	6	9,50 - 16,50	4,8	16,5	•	•	•	•	•	•	•	•	•
32	35	6	13,00 - 20,00	5,5	20	•	•	•	•	•	•	•	•	•
38	41	8	16,00 - 26,00	6,4	26	•	•	•	•	•	•	•	•	•
40	43	8	16,00 - 26,00	6,4	26	•	•	•	•	•	•	•	•	•
45	48	8	22,00 - 31,00	7,5	31	•	•	•	•	•	•	•	•	•

Forma de pedido / How to order:

Indicar / Specify	RMF_	D	L	Mat.	P o PxW	AG_
Ejemplo / Example	RMFC	10	20	HWS	P4,0	AG2
Ejemplo / Example	RMFO	32	30	HWS	P15,0 W6,0	AG3

MATRIZ LISA SALIDA RECTA CON ANTIGIRO, CON FORMA **RMG_** KEY LOCATED HEADLESS MATRIX COUNTERBORE RELIEF, SHAPED **RMG_**

Material: 1.2379 HWS
Dureza / Hardness: 62 ±2HRC

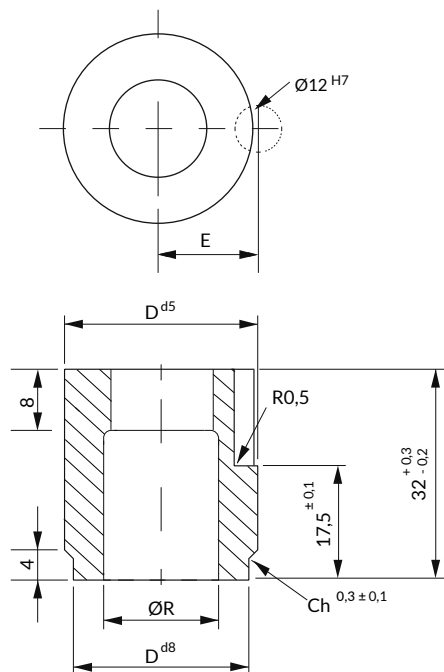

i También disponible en otros aceros y medidas bajo plano.
Also available in other steels and dimensions per dwg.

RMGC
REDONDO
ROUND

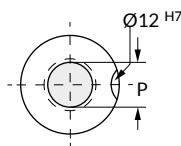

RMGO
COLISO
OBLONG

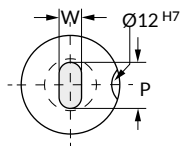

RMGR
RECTANGULAR
RECTANGLE

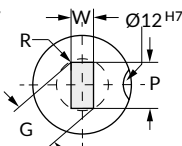

RMGH
HEXAGONAL
HEXAGON

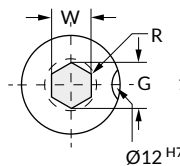

POSICIÓN ESTÁNDAR: 0°
STANDARD POSITIONING: 0°

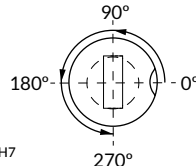

i Recomendamos montaje con tornillo **RTAM** y brida **RAAM**.
Recommended assembly with **RTAM** screw and **RAAM** flange.

i Para un posicionamiento distinto al estándar, indicar posición deseada (A_°) en pedido.
To other alternate location, specify locating device position (A_°) in your order.

Norma / Standard: NFE 63080

D	E ± 0,01	Max R	Redondo / Round	Forma / Shape	
			P	Min W	Max G/P
16	11,5	9,5	5,00 - 8,80	2,5	8,8
20	13,5	12	5,50 - 11,00	3,2	11
25	16	17,3	9,50 - 16,50	4,8	16,5
32	19,5	20,7	13,00 - 20,00	5,5	20
40	23,5	27,7	16,60 - 26,00	6,4	26
50	28,5	37	20,00 - 40,00	8	40

Forma de pedido / How to order:

Indicar / Specify	RMG_	D	Mat.	P o PxW	A_°
Ejemplo / Example	RMGC	20	HWS	P6,0	A90°
Ejemplo / Example	RMGO	32	HWS	P15,0 W6,0	A45°

MATRIZ REVERSIBLE, EN BRUTO RMHB REVERSIBLE FLAT MATRIX, BLANK RMHB

Material: 1.2379 HWS
Dureza / Hardness: 62 ±2HRC

STOCK

! Recomendamos montaje con tornillo **RTAM** y brida **RAAM**
Recommended assembly with **RTAM** screw and **RAAM** clamp

i También disponible en otros aceros y medidas bajo plano.
Also available in other steels and dimensions per dwg.

D h5	E ±0,01	P	L ^{+0,3} / ₀		
			5	8	10
13	10,5	1,5	•	•	-
16	11,5	2	•	•	-
20	13,5	2	•	•	•
25	16	2	•	•	•
32	19,5	2	•	•	-
40	23,5	2	•	•	-
50	28,5	2	•	•	-

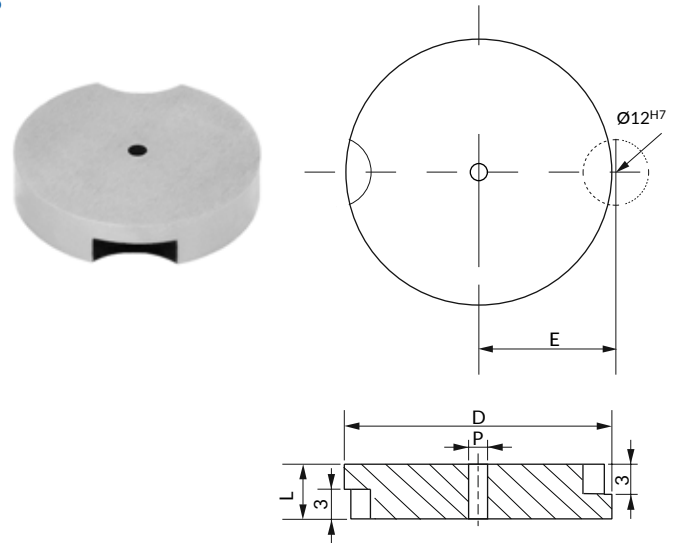

Forma de pedido / How to order:

Indicar / Specify	RMHB	D	L	Mat.
Ejemplo / Example	RMHB	20	8	HWS
Ejemplo / Example	RMHB	32	5	HWS

MATRIZ REVERSIBLE, CON FORMA RMH_ REVERSIBLE FLAT MATRIX, SHAPED RMH_

Material: 1.2379 HWS
Dureza / Hardness: 62 ±2HRC

! Recomendamos montaje con tornillo **RTAM** y brida **RAAM**
Recommended assembly with **RTAM** screw and **RAAM** clamp

! Para un posicionamiento distinto al estándar, indicar posición deseada (A_°) en pedido. / To other alternate location, specify locating device position (A_°) in your order.

i También disponible en otros aceros y medidas bajo plano.
Also available in other steels and dimensions per dwg.

D h5	E ±0,01	Redondo	Forma		L ^{+0,3} / ₀		
		Round	Min P-W	Max G,P	5	8	10
13	10,5	1,80 - 7,20	2	7	•	•	-
16	11,5	5,00 - 8,80	3	8	•	•	-
20	13,5	5,50 - 11,00	7	11	•	•	•
25	16	9,50 - 16,50	9	16	•	•	•
32	19,5	13,00 - 20,00	16	22	•	•	-
40	23,5	16,60 - 26,00	21	28	•	•	-
50	28,5	20,00 - 40,00	25	37	•	•	-

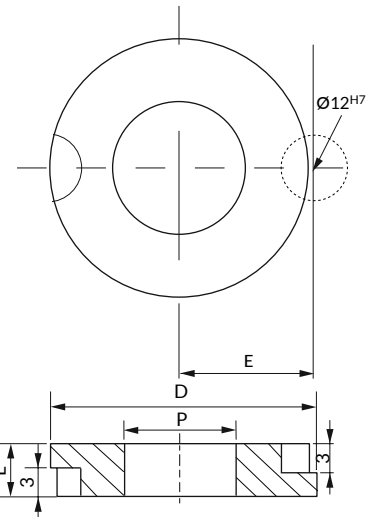

RMHC
REDONDO
ROUND

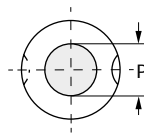

RMHO
COLISO
OBLONG

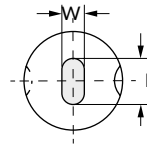

RMHR
RECTANGULAR
RECTANGLE

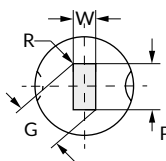

RMHH
HEXAGONAL
HEXAGON

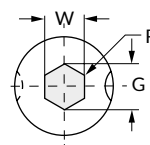

POSICIÓN ESTÁNDAR: 180°
STANDARD POSITIONING: 180°

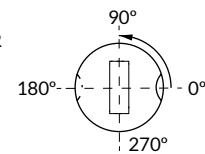

Forma de pedido / How to order:

Indicar / Specify	RMH_	D	L	Mat.	P o PxW	A_°
Ejemplo / Example	RMHO	20	8	HWS	P4,0	A100°
Ejemplo / Example	RMHR	32	5	HWS	P20,0 W18,0	A20°

CASQUILLO GUÍA PUNZÓN RMSC PUNCH GUIDING BUSH RMSC

Material: 1.7264

Dureza / Hardness: 60 ±2HRC



i También disponible en otros aceros y medidas bajo plano.
Also available in other steels and dimensions per dwg.

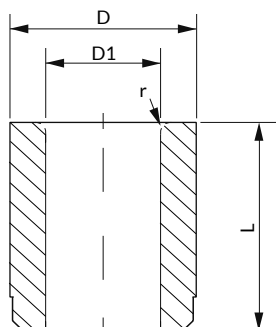

Norma / Standard: DIN 9845 C

D1 H7	D n6	L	r
2,10 - 3,0	7	12	1
3,10 - 4,0	8	12	1
4,10 - 5,0	10	16	1
5,10 - 6,0	12	16	1,5
6,10 - 8,0	15	20	1,5
8,10 - 10,0	18	20	2
10,10 - 12,0	22	28	2
12,10 - 15,0	26	28	2
15,50 - 18,0	30	36	2

Forma de pedido / How to order:

Indicar / Specify	RMSC	D1	L
Ejemplo / Example	RMSC	10	20
Ejemplo / Example	RMSC	5	28

BRIDA DE AMARRE PARA MATRIZ RBAM CLAMP FOR MATRIX RBAM

Material: CK 45

STOCK



i Brida para amarre de matrices [RMA_](#), [RME_](#), [RMH_](#) y [RMG_](#)
Clamp for fastening [RMA_](#), [RME_](#), [RMH_](#) and [RMG_](#) matrix

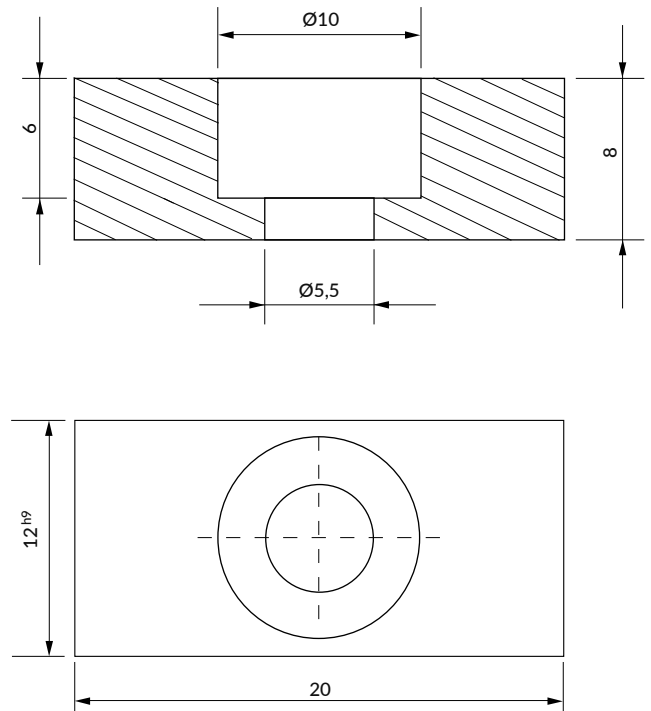

Forma de pedido: RBAM
How to order: RBAM

BRIDA DE AMARRE PARA MATRIZ RBAF CLAMP FOR MATRIX RBAF

Material: CK 45

STOCK

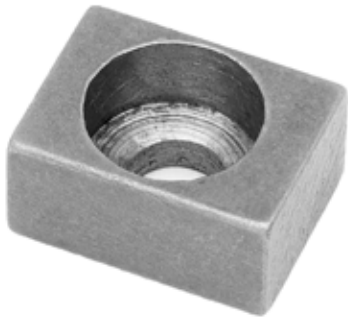

i Brida para amarre de matrices [RMA_](#) y [RME_](#)
Clamp for fastening [RMA_](#) and [RME_](#) matrix

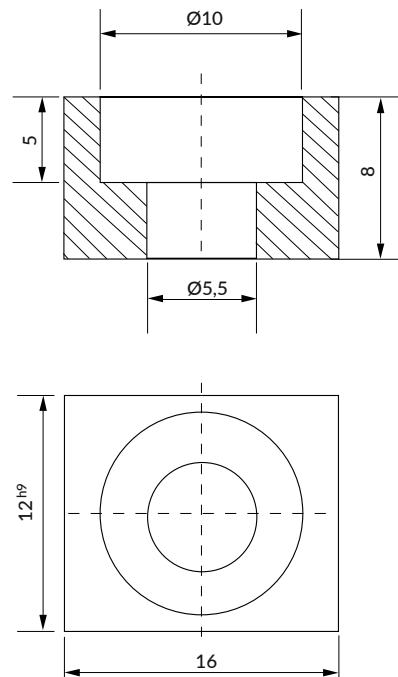

Forma de pedido: RBAF
How to order: RBAF

TORNILLO DE AMARRE PARA MATRIZ RTAM

SCREW FOR MATRIX RTAM

Material: 1.7225

STOCK

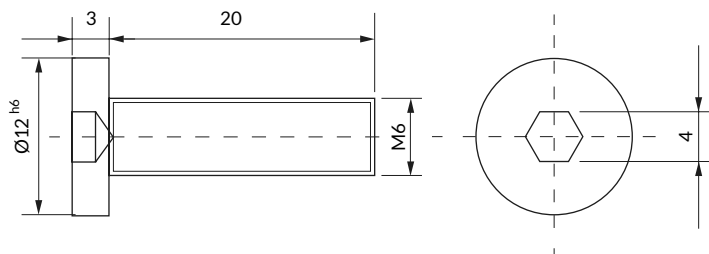

i Tornillo para amarre de matrices **RMH_** y **RMG_**
Screw for fastening **RMH_** and **RMG_** matrix

Forma de pedido: RTAM
How to order: RTAM

BRIDA DE AMARRE PARA MATRIZ RAAM

CLAMP FOR MATRIX RAAM

STOCK

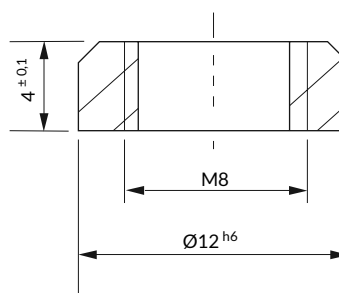

i Brida para amarre de matrices **RMH_** y **RMG_**
Clamp for fastening **RMH_** and **RMG_** matrix

Forma de pedido: RAAM
How to order: RAAM

DESPEGADOR DE URETANO RMTC HEADLESS URETHANE STRIPPER RMTC

Dureza / Hardness: 95 ± 5 Shore A

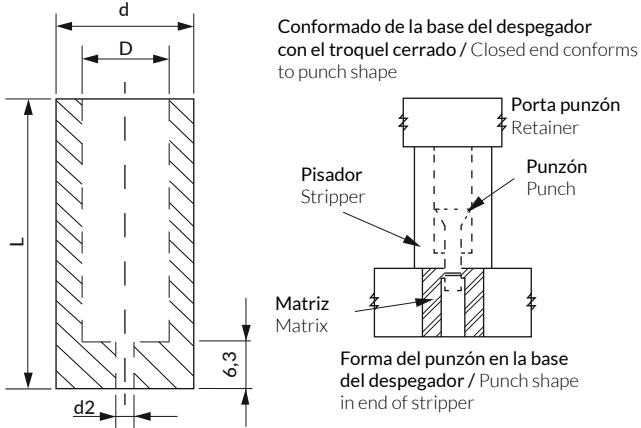

Despegador RMTC vs despegadores en forma de tubo
RMTC stripper vs tubetype strippers

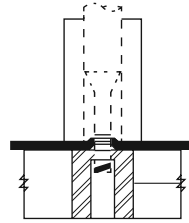

Utilizando un despegador sin base
la chapa es arrastrada
Material can be pulled upward
when using tubetype strippers

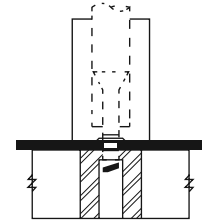

Utilizando un despegador con base
la chapa se mantiene fija
Strip-shape strippers hold stock flat

i Deflexión máx, recomendada: 15% de la longitud total
Max, Recommended Deflection: 15% of overall-length

D	L ± 1.5	d	d2	Presión con deflexión de (N) / Pressure at deflection of (N)		
				3,0 mm	6,5 mm	9,5 mm
6	45	19	1,6	1324	2256	-
6	53	19	1,6	1079	1863	2354
6	71	19	1,6	686	1079	1765
8	45	21	1,6	1471	2207	-
8	53	21	1,6	1324	1961	2942
8	71	21	1,6	981	1618	2648
10	45	23	1,6	1716	2795	-
10	53	23	1,6	1422	2452	3187
10	56	23	1,6	1422	2452	3187
10	71	23	1,6	1128	2010	2697
13	45	26	3,2	2109	3334	-
13	53	26	3,2	1471	2354	3432
13	56	26	3,2	1471	2354	2942
13	71	26	3,2	1275	1961	2452
16	45	30	3,2	2354	3825	-
16	53	30	3,2	2158	3531	4511
16	56	30	3,2	2158	3431	4511
16	71	30	3,2	1814	2942	3825
20	45	38	3,2	2452	3923	-
20	53	38	3,2	2158	3629	5590
20	71	38	3,2	1618	2942	4658
25	45	50	3,2	9317	14318	-
25	53	50	3,2	7355	11572	15985
25	71	50	3,2	4904	8336	13485

Forma de pedido: RMTC + D * L
How to order: RMTC + D * L

DESPEGADOR DE URETANO CON VALONA RMTS HEADED URETHANE STRIPPER RMTS



Dureza / Hardness: 95 ±5 Shore A

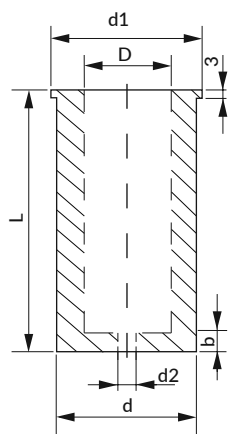

Conformado de la base del despegador con el troquel cerrado / Closed end conforms to punch shape

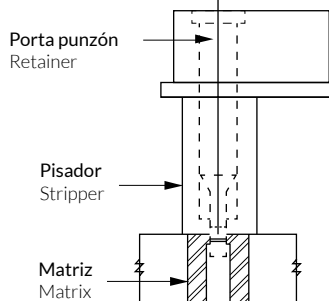

Forma del punzón en la base del despegador / Punch shape in end of stripper

Despegador RMTS vs despegadores en forma de tubo
RMTS stripper vs tubetype strippers

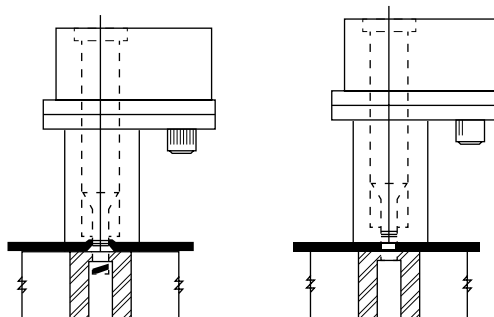

Utilizando un despegador sin base la chapa es arrastrada
Material can be pulled upward when using tubetype strippers

Utilizando de un despegador con la chapa se mantiene fija
Strip-shape strippers hold stock flat

i Deflexión máx, recomendada: 15% de la longitud total
Max. Recommended Deflection: 15 % of overall-length

D	L ± 1.5	d	d1	d2	b	Presión con deflexión de (N) / Pressure at deflection of (N)		
						3,0 mm	6,5 mm	9,5 mm
10	44	18	21	1,6	6	1060	1820	-
10	54	18	21	1,6	6	900	1650	2170
10	64	18	21	1,6	6	720	1450	1860
10	74	18	21	1,6	6	570	1280	1610
13	44	23	26	3,0	6	1700	2850	-
13	54	23	26	3,0	6	1460	2610	3410
13	64	23	26	3,0	6	1170	2320	2910
13	74	23	26	3,0	6	930	2080	2500
16	44	28	31	3,0	6	2310	3900	-
16	54	28	31	3,0	6	1990	3560	4640
16	64	28	31	3,0	6	1590	3150	3980
16	74	28	31	3,0	6	1270	2810	3440
20	44	33	36	3,0	7	2900	4900	-
20	54	33	36	3,0	7	2500	4470	5820
20	64	33	36	3,0	7	2000	3950	5000
20	74	33	36	3,0	7	1590	3420	4330
25	44	40	43	3,0	7	4440	7520	-
25	54	40	43	3,0	7	3810	6860	8780
25	64	40	43	3,0	7	3050	6050	7680
25	74	40	43	3,0	7	2420	5390	6780
32	44	50	55	3,0	7	6840	11390	-
32	54	50	55	3,0	7	5880	10450	13300
32	64	50	55	3,0	7	4700	9310	11640
32	74	50	55	3,0	7	3740	8370	10280
38	54	60	65	3,0	8	9480	19330	29720
38	74	60	65	3,0	8	5950	11630	18160
40	44	60	65	3,2	8	10100	20190	-
40	54	60	65	3,2	8	8650	17300	25960
40	64	60	65	3,2	8	6890	13780	20670

Largo punzón cambio rápido carga fuerte (con porta punzón RPPH o RPPR) Heavy duty ball lock punch length (with RPPH or RPPR retainer)	Largo punzón cabeza cilíndrica (con porta punzón RPPI o RPPIA) Cylindrical head punch length (with RPPI or RPPIA retainer)	Largo recomendado para despegador "L" Recommended Stripper Length "L"
80	71	44
90	80	54
100	90	64
110	100	74

Forma de pedido: RMTS + D * L

How to order: RMTS + D * L

BRIDA PARA DESPEGADOR DE URETANO CON VALONA RMTR HEADED URETHANE STRIPPER RETAINER RMTR



i Válido para porta punzones RPPH, RPPI y RPPIA
For shaped punches RPPH, RPPI and RPPIA

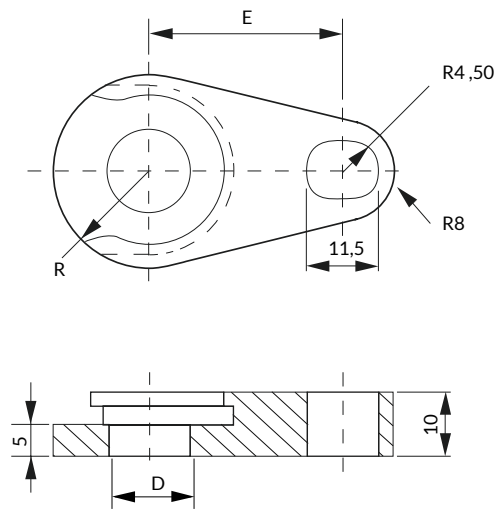

D	R	E
10	13	28
13	15,5	31
16	18	32,9
20	20,5	34,8
25	24	39,8
32	31	41,3
40	36	45

Forma de pedido: RMTR + D
How to order: RMTR + D

BRIDA PARA DESPEGADOR DE URETANO CON VALONA RMTP

HEADED URETHANE STRIPPER RETAINER RMTP



i Válido para porta punzón RPPR
For shaped punch RPPR

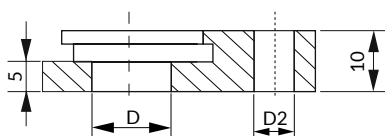
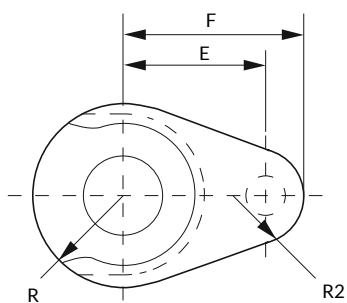

D	R	E	F	D2	R2
10	13	21,0	26,5	7	10,0
13	15,5	23,9	29,4	7	11,0
16	18,0	24,5	30,0	7	12,8
20	20,5	29,0	36,0	9	11,8
25	24,0	33,5	40,5	9	12,9
32	31,0	40,6	49,3	9	8,0
40	36,0	44,0	53,0	9	8,0

Forma de pedido: RMTP + D
How to order: RMTP + D

ANTIGIROS PARA PRODUCTOS CON CABEZA / VALONA AG_ LOCATING DEVICES FOR HEADED PRODUCTS AG_

i Los punzones y las matrices siempre se miran a troquel cerrado
Parts are viewed in die position looking from above the die

AG 1

Fresado / Key Flat

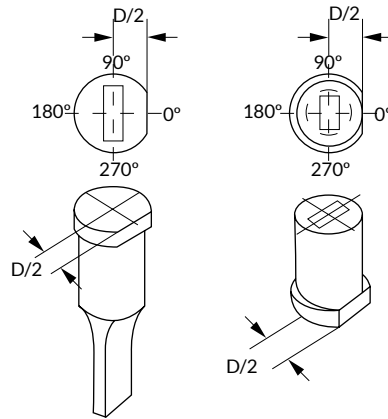

AG 2

Doble fresado / Double flat

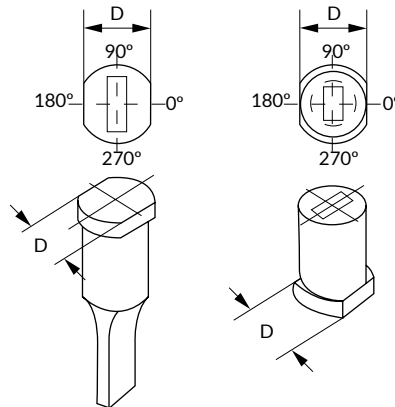

AG 3

Cuerpo fresado / Body flat

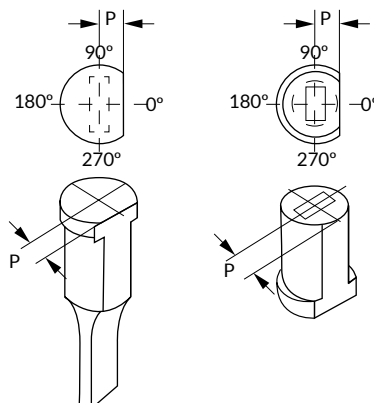

i Especificar P en pedido
Specify P in your order

ANTIGIROS EN MATRIZ LISA AG_ LOCATING DEVICES IN HEADLESS MATRIX AG_

i Los punzones y las matrices siempre se miran a troquel cerrado
Parts are viewed in die position looking from above the die

AG 4
Fresado / Key Flat

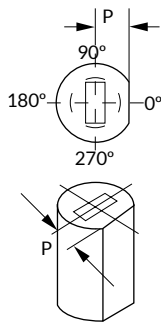

AG 5
Fresado arriba
Step flat top

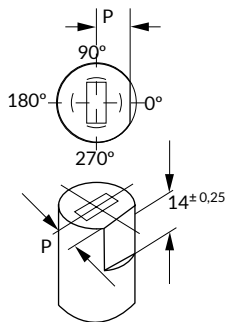

AG 6
Fresado abajo
Step flat bottom

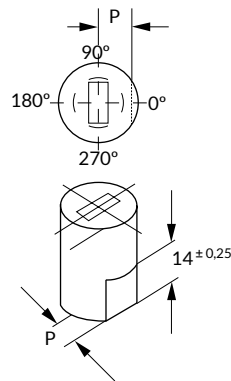

AGS
Customizable
Customizable

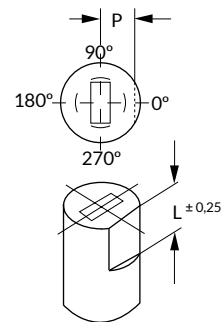

i Especificar P y L en pedido
Specify P and L in your order

D	$p \begin{smallmatrix} +0,02 \\ 0 \end{smallmatrix}$
8	3,5
10	4
13	5,5
16	7
20	8,5
22	9,5
25	11
32	14
38	17
40	18
45	20,5
50	23
56	26
63	29,5
71	33,5
76	35,5
85	40
90	42,5
100	47,5

RANURA PARA PASADOR AG_ DOWEL SLOT AG_

i Los punzones y las matrices siempre se miran a troquel cerrado
Parts are viewed in die position looking from above the die

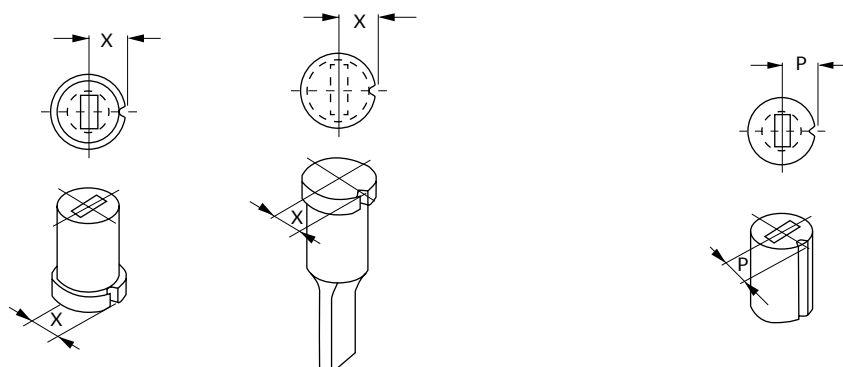

$$X = \frac{D + \varnothing \text{ pasador / dowel}}{2}$$

P= según tabla / as shown on chart

i Para \varnothing de pasador distinto a 3, 4 o 6, indicar \varnothing y P en pedido
For dowel \varnothing different to 3, 4 or 6, specify \varnothing and P in your order

Tabla para matrices lisas / Chart for headless matrix

D	p $\pm 0,013$			
	Pasador $\varnothing 3$ / $\varnothing 3$ dowel	Pasador $\varnothing 4$ / $\varnothing 4$ dowel	Pasador $\varnothing 6$ / $\varnothing 6$ dowel	Otros \varnothing / Other \varnothing
10	5,5	6	7	Especificar en pedido / Specify in your order
13	6,7	7,2	8,2	Especificar en pedido / Specify in your order
16	8	8	9	Especificar en pedido / Specify in your order
20	10	10	11	Especificar en pedido / Specify in your order
22	11	11	12	Especificar en pedido / Specify in your order
25	12,5	12,5	13,5	Especificar en pedido / Specify in your order
≥ 32	D/2	D/2	D/2	Especificar en pedido / Specify in your order

\varnothing de pasador / Dowel \varnothing	Forma de pedido / How to order
3	AG 7
4	AG 8
6	AG 9
otra other	AGP + \varnothing de pasador + P AGP + Dowel \varnothing + P

ALTERACIONES ESTÁNDAR EN LONGITUD AL1 STANDARD ALTERATIONS IN LENGTH AL1

Se reduce el largo total (L), manteniendo la L1 / Reduces total length (L), maintaining L1
No disponible para matrices con valona salida recta / Not available in headed counterbore matrixes

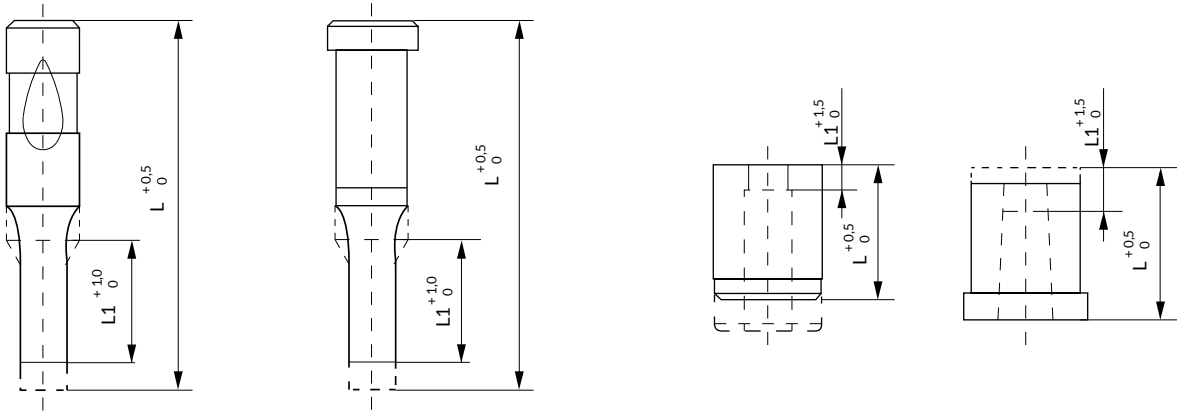

Forma de pedido: AL1+ nueva L
How to order: AL1+ new L

ALTERACIONES ESTÁNDAR EN LONGITUD AL2 STANDARD ALTERATIONS IN LENGTH AL2

Se reduce el largo total (L), y también la L1 / Reduces total length (L), and also L1

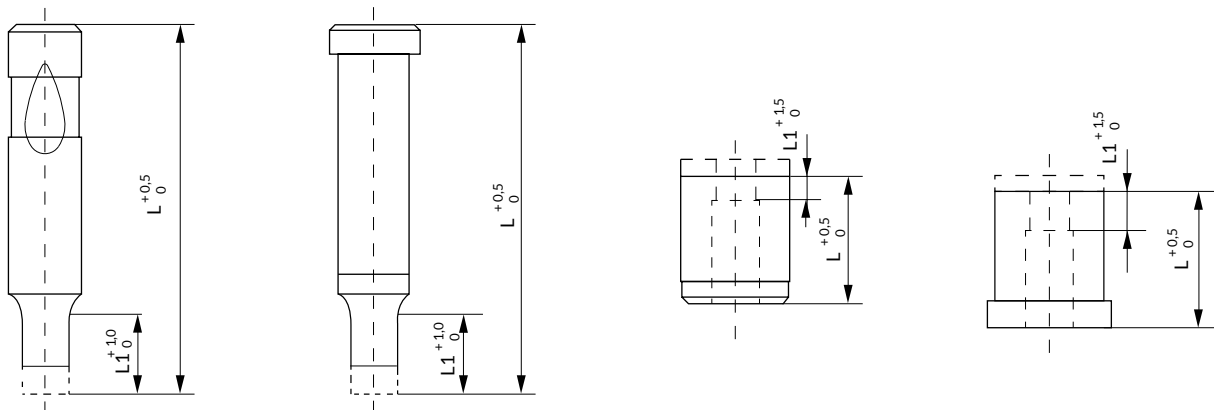

Forma de pedido: AL2+ nueva L
How to order: AL2+ new L

ALTERACIONES ESTÁNDAR EN LONGITUD AL3 STANDARD ALTERATIONS IN LENGTH AL3

Se reduce el largo total (L), y también la L1, con una precisión de $\pm 0,02$ en el largo total
Reduces total length (L), and also L1, with a precision of $\pm 0,02$ overall length

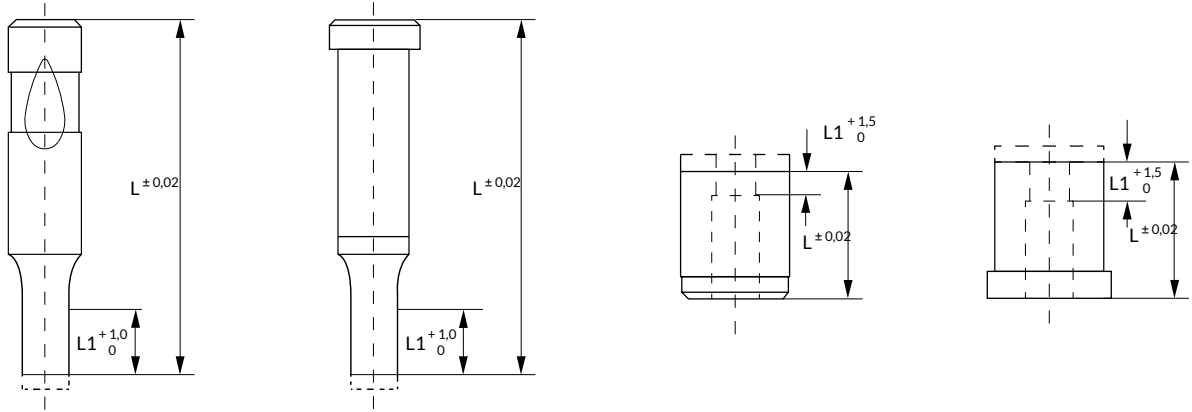

Forma de pedido: AL3 + nueva L
How to order: AL3 + new L

ALTERACIONES ESTÁNDAR EN CABEZA AL_ STANDARD ALTERATIONS IN HEAD AL_

AL 4

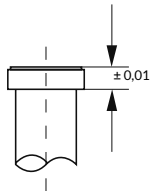

Espesor de cabeza (K) de precisión, se reduce la L total / Provides a precision head length (K) but reduces overall length (L)

AL 5

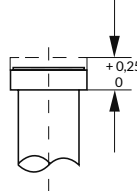

Se reducen el espesor de cabeza (K) y la L total / Reduces head length (K) but also overall length (L)

AL 6

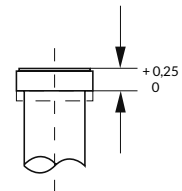

Se reduce el espesor de cabeza (K) manteniendo la L total / Reduces head length (K) maintaining overall length (L)

Forma de pedido: AL_ + nueva K
How to order: AL_ + new K

AL 7

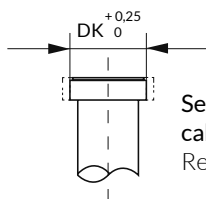

Se reduce el diámetro de la cabeza (DK) / Reduces head diameter (DK)

Forma de pedido: AL7 + nueva DK
How to order: AL7 + new DK

AL 8

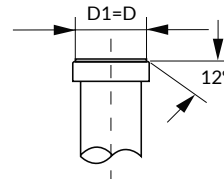

Ángulo en la cabeza para incrementar la fuerza / Angle on head face to improve strength

Forma de pedido: AL8
How to order: AL8

ALTERACIONES ESTÁNDAR EN DIÁMETRO DE CUERPO XD STANDARD ALTERATIONS IN BODY DIAMETER XD

Reduce el diámetro del cuerpo (D), sin alterar el de la cabeza (DK) / Reduces body diameter (D), maintaining head diameter (DK)
Disponible sólo para punzones con cabeza, y todo tipo de matrices / Only available for headed punches and any matrix,

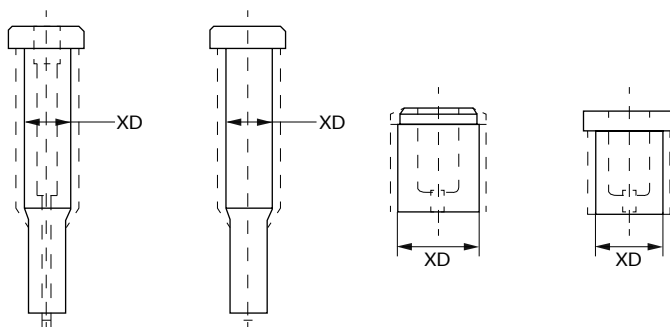

	XD Min para D inicial de / Min XD for initial D of											
	5	6	8	10	13	16	20	22	25	32	38	40
Punzón / Punch RPAX, RPVC	3,5	5,0	6,5	8,5	11,5	14,5	18,5	-	23,5	30,5	-	38,5
Punzón / Punch RPBX, RPZC	4,5	5,0	6,8	9	11,5	14,5	18,5	-	23,5	30,5	-	38,5
Matriz / Matrix	-	-	6,5	8,5	11,5	14,5	18,5	20,5	23,0	30,0	36,0	38,0

Forma de pedido: XD + nueva D
How to order: XD + new D

ALTERACIÓN DE CONTROL DE VIRUTA CV SLUG CONTROL ALTERATION CV

i Indicar espesor de material (EM) y tolerancia por lado (TL) en el pedido.
Specify material thickness (EM) and die clearance per side (TL) in your order.

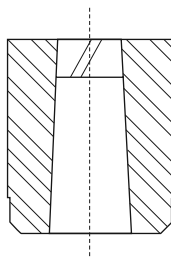

Forma de pedido: CV + EM + TL
How to order: CV + EM + TL

TRATAMIENTOS Y RECUBRIMIENTOS SURFACE TREATMENTS AND COATINGS

TiN

Materiales / Materials: Nitruro de Titanio / Titanium Nitride

Color: Dorado / Gold

Dureza / Hardness: 2300HV

Máx. Temp. de trabajo / Max. Service Temp.: 600°C

Uso recomendado / Applications: estampación de materiales de baja dureza. No recomendado para uso con acero inoxidable, níquel o cobre. / Light stamping operations. Not compatible for use with stainless steel, nickel or copper.

Características / Features:

- ☑ Excelente resistencia al desgaste. / Excellent wear resistance.
- ☑ Excelente lubricidad. / Excellent lubricity.
- ☑ Estabilidad térmica en aplicaciones de estampación en frío. / Suitable thermal stability for cold work metalworking applications.

TiCN

Materiales / Materials: Carbonitruro de Titanio / Titanium CarboNitride

Color: Gris azulado / Blue-grey

Dureza / Hardness: 3000HV

Máx. Temp. de trabajo / Max. Service Temp.: 400°C

Uso recomendado / Applications: Embutición y corte de acero inoxidable, níquel o cobre. / Forming and piercing of stainless steel, nickel and copper.

Características / Features:

- ☑ Extrema dureza y enorme tenacidad. / Excellent toughness.
- ☑ Elevada resistencia al desgaste. / High wear resistance.
- ☑ Mayor lubricidad que el TiN. / Improved lubricity over TiN.

TiAlN

Materiales / Materials: Nitruro de Titanio al Aluminio / Titanium Aluminium Nitride

Color: Violeta-gris / Violet-grey

Dureza / Hardness: 3400HV

Máx. Temp. de trabajo / Max. Service Temp.: 900°C

Uso recomendado / Applications: Conformado y embutición de chapas de resistencia media, y componentes sometidos a mucha tensión / Forming and extruding of medium strength steels and highly stressed components,

Características / Features:

- ☑ Extrema dureza y enorme tenacidad. / Excellent toughness.
- ☑ Elevada resistencia al desgaste por abrasión. / Excellent protection against abrasive wear.
- ☑ Una mayor estabilidad química y térmica permite una mayor velocidad de golpe. / A high thermal and chemical stability allows increased press stroke speed.
- ☑ Mayor lubricidad debido a una mayor calidad de la superficie. / Improved lubricity due to a higher surface quality.

AlCrN

Materiales / Materials: Nitruro de Aluminio de Cromo / Aluminium Chromium Nitride

Color: Gris brillante / Bright grey

Dureza / Hardness: 3200HV

Máx. Temp. de trabajo / Max. Service Temp.: 1100°C

Uso recomendado / Applications: Corte, conformado y punzonado de metales duros, así como estampación en caliente o aplicaciones de gran carga mecánica. / Piercing and forming of high-strength steels, as well as hot stamping and high mechanical load applications.

Características / Features:

- ☑ Elevada resistencia al desgaste. / Extraordinarily high wear resistance.
- ☑ Excelente dureza en caliente. / Excellent toughness in high temperatures.
- ☑ Una mayor estabilidad química y térmica permite una mayor velocidad de golpe. / A high thermal and chemical stability allows increased press stroke speed.

TOLERANCIAS PUNZÓN-MATRIZ PUNCH-DIE CLEARANCES

La tolerancia entre el punzón y la matriz se calcula en base al material y el grosor de la chapa que queremos punzonar, el acabado deseado del agujero y la vida útil prevista para el punzón. La tolerancia utilizada en la mayoría de los casos varía entre un 5% y un 12% aproximadamente por lado, consiguiendo así una mayor superficie pulida en el agujero; reduciendo el redondeo superficial y arrastre de material. Estas condiciones de trabajo provocan una mayor fricción, acortando la vida útil del punzón.

Un aumento de la tolerancia (9-20%), genera una menor superficie pulida y un mayor redondeo superficial y arrastre de material. A su vez, estas condiciones han demostrado que pueden reducir la rebaba y prolongar la vida útil del punzón, pero se recomienda utilizar punzones con expulsor para evitar que la pepita salga hacia arriba al extraer el punzón.

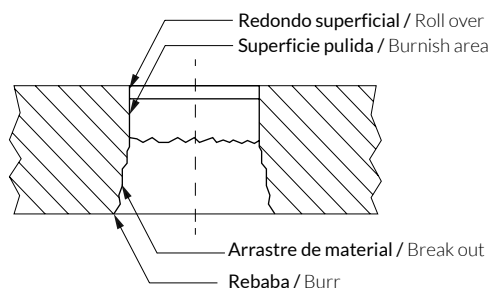

En la tabla se muestran las tolerancias recomendadas en función del material a estampar.

Ejemplo / Example

Agujero de Ø12,80 en chapa de aluminio de espesor de 1 mm / Ø12,80 hole in 1 mm aluminium stock thickness

Tolerancia total (= 10% de tolerancia por cada lado * 2) / Total punch-to-die clearance (= 10% clearance per side * 2)	0,20 mm
Diámetro de punta del punzón / Punch Point Size	12,80mm
Diámetro interior de matriz / Matrix Hole Size	13,00mm

Clearance between punch and die is based upon type of material being stamped, material thickness, finish requirement of hole and anticipated tool life. The long-time used clearance varies approximately between 5-12% of the stock thickness per side, producing a high percentage of shear or burnish area, and a minimal rollover and break, but also a high wear, shortening the life of the punch.

A significant increase in clearance (9-20%) creates a lower percentage of shear or burnish and a greater rollover and break. It has been proved that these conditions reduce burr height and improve the life of the punch, but we recommend using an ejector pin, in order to eliminate the risk of the slug being pulled up when retracting the punch.

The table below offers some guidelines for different types of material being stamped.

Material	Tolerancia estándar / Standard clearance	Tolerancia óptima (con expulsor) / Optimum clearance (with ejector)
Aluminio / Aluminium	5-12%	12-20%
Latón / Brass	4-10%	10-16%
Cobre / Copper	4-10%	10-16%
Acero (bajo en carbono) / Steel (low carbon)	10-14%	16-20%
Acero (alto en carbono) / Steel (high carbon)	18-25%	26-32%

EXPULSOR NITRURADO EXPA EJECTOR PIN BLACK NITRIDED EXPA

Material: 1.2344

Dureza / Hardness:

Superficie / Surface: 70 HRC

Núcleo / Core: 40-45HRC

Cabeza / Head: 45±5HRC

STOCK

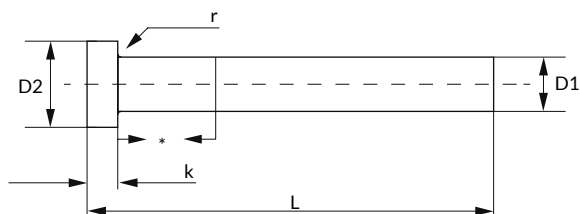

* En los expulsores se admite una desviación de la rugosidad o de la cota D1, en parte de la longitud.

* A deviation of the surface roughness or diameter D1 over a certain length is permitted for ejector pins.

i Temperatura de trabajo máxima: 650°C
Maximum working temperature: 650°C

Norma / Standard: DIN 1530 – ISO 6751

D1 g6	D2 -0,2	K -0,05	r	L + 2													
				100	125	160	200	250	315	400	500	630	800	1000	1250	1400	
1,5	3	1,5	0,2	•	•	•	•				-	-	-	-	-	-	
2	4	2	0,2	•	•	•	•	•	•		-	-	-	-	-	-	
2,2	4	2	0,2	•	•	•	•	•	•		-	-	-	-	-	-	
2,5	5	2	0,3	•	•	•	•	•	•		-	-	-	-	-	-	
2,7	5	2	0,3	•	•	•	•	•	•		-	-	-	-	-	-	
3	6	3	0,3	•	•	•	•	•	•	•	•	-	-	-	-	-	
3,2	6	3	0,3	•	•	•	•	•	•	•		-	-	-	-	-	
3,5	7	3	0,3	•	•	•	•	•	•	•		-	-	-	-	-	
3,7	7	3	0,3	•	•	•	•	•	•	•		-	-	-	-	-	
4	8	3	0,3	•	•	•	•	•	•	•	•	•	-	-	-	-	
4,2	8	3	0,3	•	•	•	•	•	•	•		-	-	-	-	-	
4,5	8	3	0,3	•	•	•	•	•	•	•		-	-	-	-	-	
5	10	3	0,3	•	•	•	•	•	•	•	•	•	•	•	-	-	
5,2	10	3	0,3	•	•	•	•	•	•	•		-	-	-	-	-	
5,5	10	3	0,3	•	•	•	•	•	•	•		-	-	-	-	-	
6	12	5	0,5	•	•	•	•	•	•	•	•	•	•	•	•	-	
6,2	12	5	0,5	•	•	•	•	•	•	•		-	-	-	-	-	
6,5	12	5	0,5	•	•	•	•	•	•	•		-	-	-	-	-	
7	12	5	0,5	•	•	•	•	•	•	•	•	-	-	-	-	-	
7,5	14	5	0,5	•	•	•	•	•	•	•		-	-	-	-	-	
8	14	5	0,5	•	•	•	•	•	•	•	•	•	•	•	•	-	
8,2	14	5	0,5	•	•	•	•	•	•	•		-	-	-	-	-	
8,5	14	5	0,5	•	•	•	•	•	•	•		-	-	-	-	-	
9	14	5	0,5	•	•	•	•	•	•	•	•	•	•	•	•	-	
10	16	5	0,5	•	•	•	•	•	•	•	•	•	•	•	•	•	
10,2	16	5	0,5	•	•	•	•	•	•	•		-	-	-	-	-	
10,5	16	5	0,5	•	•	•	•	•	•	•		-	-	-	-	-	
11	16	5	0,8	•	•	•	•	•	•	•	•	•	•	•	•	-	
12	18	7	0,8	•	•	•	•	•	•	•	•	•	•	•	•	•	
12,2	18	7	0,8	•	•	•	•	•	•	•		-	-	-	-	-	
12,5	18	7	0,8	•	•	•	•	•	•	•		-	-	-	-	-	
14	22	7	0,8	•	•	•	•	•	•	•	•	•	•	•	•	•	
16	22	7	0,8	•	•	•	•	•	•	•	•	•	•	•	•	•	
18	24	7	0,8	•	•	•	•	•	•	•	•	•	•	•	•	•	
20	26	8	1	•	•	•	•	•	•	•	•	•	•	•	•	•	
25	32	10	1	-	-	-	-	•	•	•	•	•	•	•	•	•	
32	40	10	1	-	-	-	-	•	•	•	•	•	•	•	•	•	

Forma de pedido: EXPA + D1*L

How to order: EXPA + D1*L

EXPULSOR TEMPLADO CABEZA CILÍNDRICA EXPB CYLINDRICAL HEAD EJECTOR PIN HARDENED EXPB

Material: 1.2510

Dureza / Hardness:

Cuerpo / Body: 60±2HRC

Cabeza / Head: 45±5HRC

STOCK

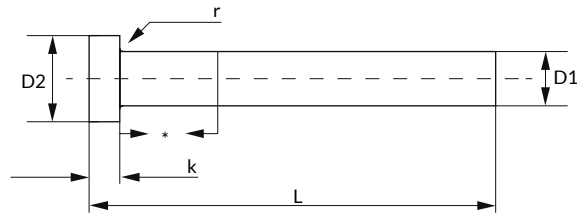

* En los expulsores se admite una desviación de la rugosidad o de la cota D1, en parte de la longitud.

* A deviation of the surface roughness or diameter D1 over a certain length is permitted for ejector pins.

 Temperatura de trabajo máxima: 220°C
Maximum working temperature: 220°C

Norma / Standard: DIN 1530 – ISO 6752

D1g6	D2-0,2	K-0,05	r	L+2							
				100	125	160	200	250	315	400	500
1,5	3	1,5	0,2	•	•	•	•	-	-	-	-
1,6	3	1,5	0,2	•	•	•	•	-	-	-	-
1,7	3	1,5	0,2	•	•	•	•	-	-	-	-
1,8	3	1,5	0,2	•	•	•	•	-	-	-	-
2	4	2	0,2	•	•	•	•	•	•	-	-
2,2	4	2	0,2	•	•	•	•	•	•	-	-
2,5	5	2	0,3	•	•	•	•	•	•	-	-
2,7	5	2	0,3	•	•	•	•	•	•	-	-
3	6	3	0,3	•	•	•	•	•	•	•	•
3,2	6	3	0,3	•	•	•	•	•	•	•	-
3,5	7	3	0,3	•	•	•	•	•	•	•	-
3,7	7	3	0,3	•	•	•	•	•	•	•	-
4	8	3	0,3	•	•	•	•	•	•	•	•
4,2	8	3	0,3	•	•	•	•	•	•	•	-
4,5	8	3	0,3	•	•	•	•	•	•	•	-
5	10	3	0,3	•	•	•	•	•	•	•	•
5,2	10	3	0,3	•	•	•	•	•	•	•	-
5,5	10	3	0,3	•	•	•	•	•	•	•	-
6	12	5	0,5	•	•	•	•	•	•	•	•
6,2	12	5	0,5	•	•	•	•	•	•	•	-
6,5	12	5	0,5	•	•	•	•	•	•	•	-
7	12	5	0,5	•	•	•	•	•	•	•	-
8	14	5	0,5	•	•	•	•	•	•	•	•
8,2	14	5	0,5	•	•	•	•	•	•	•	-
8,5	14	5	0,5	•	•	•	•	•	•	•	-
9	14	5	0,5	•	•	•	•	•	•	•	-
10	16	5	0,5	•	•	•	•	•	•	•	•
10,2	16	5	0,5	•	•	•	•	•	•	•	-
10,5	16	5	0,5	•	•	•	•	•	•	•	-
11	16	5	0,8	•	•	•	•	•	•	•	-
12	18	7	0,8	•	•	•	•	•	•	•	•
12,2	18	7	0,8	•	•	•	•	•	•	•	-
12,5	18	7	0,8	•	•	•	•	•	•	•	-
14	22	7	0,8	•	•	•	•	•	•	•	•
16	22	7	0,8	•	•	•	•	•	•	•	•
18	24	7	0,8	•	•	•	•	•	•	•	•
20	26	8	1	•	•	•	•	•	•	•	•

Forma de pedido: EXPB + D1*L

How to order: EXPB + D1*L

EXPULSOR TEMPLADO CABEZA CÓNICA EXPD CONICAL HEAD EJECTOR PIN HARDENED EXD

Material: 1.2510

Dureza / Hardness:

Superficie / Surface: 70 HRC

Cabeza / Head: 45±5HRC

STOCK

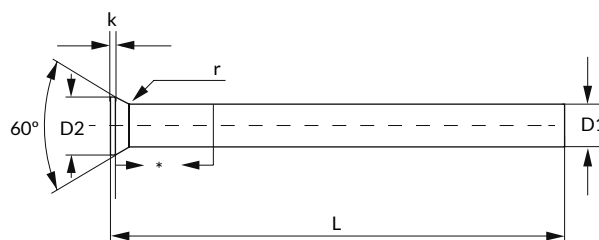

* En los expulsores se admite una desviación de la rugosidad o de la cota D1, en parte de la longitud.

* A deviation of the surface roughness or diameter D1 over a certain length is permitted for ejector pins.



Temperatura de trabajo máxima: 220°C

Maximum working temperature: 220°C

Norma / Standard: DIN 1530

D1 g6	D2 -0,2	K -0,05	r	L + 2					
				100	125	160	200	250	315
1	1,8	0,5	0,3	•	•	•	•	-	-
1,1	1,8	0,5	0,3	•	•	•	•	-	-
1,2	2	0,5	0,3	•	•	•	•	-	-
1,25	2	0,5	0,3	•	•	•	•	-	-
1,3	2	0,5	0,3	•	•	•	•	-	-
1,4	2,2	0,5	0,3	•	•	•	•	-	-
1,5	2,2	0,5	0,3	•	•	•	•	-	-
1,6	2,5	0,5	0,3	•	•	•	•	-	-
1,7	2,5	0,5	0,3	•	•	•	•	-	-
1,75	2,8	0,5	0,3	•	•	•	•	-	-
1,8	2,8	0,5	0,3	•	•	•	•	-	-
1,9	2,8	0,5	0,3	•	•	•	•	-	-
2	3	0,5	0,3	•	•	•	•	-	-
2,1	3,2	0,5	0,3	•	•	•	•	-	-
2,2	3,2	0,5	0,3	•	•	•	•	-	-
2,3	3,5	0,5	0,3	•	•	•	•	-	-
2,4	3,5	0,5	0,3	•	•	•	•	-	-
2,5	3,5	0,5	0,3	•	•	•	•	-	-
2,6	4	0,5	0,3	•	•	•	•	-	-
2,7	4	0,5	0,3	•	•	•	•	-	-
2,8	4	0,5	0,3	•	•	•	•	-	-
2,9	4	0,5	0,3	•	•	•	•	-	-
3	4,5	0,5	0,3	•	•	•	•	•	-
3,5	5	0,5	0,3	•	•	•	•	•	•
4	5,5	0,5	0,3	•	•	•	•	•	•
4,5	6	0,5	0,3	•	•	•	•	•	•
5	6,5	0,5	0,3	•	•	•	•	•	•
5,5	7	0,5	0,5	•	•	•	•	•	•
6	8	0,5	0,5	•	•	•	•	•	•
6,5	9	1	0,5	•	•	•	•	•	•
7	9	1	0,5	•	•	•	•	•	•
7,5	10	1	0,5	•	•	•	•	•	•
8	10	1	0,5	•	•	•	•	•	•
8,5	11	1	0,5	•	•	•	•	•	•
9	11	1	0,5	•	•	•	•	•	•
10	12	1	0,5	•	•	•	•	•	•
10,5	13	1	0,5	•	•	•	•	•	•
11	13	1	0,5	•	•	•	•	•	•
12	14	1	0,5	•	•	•	•	•	•
13	15	1,5	0,5	•	•	•	•	•	•
14	16	1,5	0,8	•	•	•	•	•	•
15	17	1,5	0,8	•	•	•	•	•	•
16	18	1,5	0,8	•	•	•	•	•	•

Forma de pedido: EXPD + D1*L

How to order: EXPD + D1*L

ELEMENTOS DE GUIADO SLIDING ELEMENTS



Nuestra línea de elementos de guiado ofrece una gran variedad de artículos para satisfacer las necesidades de diseño y construcción de troqueles. Todos estos elementos se producen según los estrictos requerimientos de calidad en cuanto a materiales, tolerancias y tratamientos, para garantizar la fiabilidad y durabilidad de nuestros productos.

Además, podemos diseñar y fabricar productos especiales de guiado, para dar solución a necesidades particulares de producción.

Our selection of sliding elements offers a vast variety of items set to satisfy the highest requirements regarding the design and construction of sheet metal working dies. All these elements are produced in accordance with the highest quality requirements in terms of materials, tolerances and treatments, in order to guarantee a reliable and a long lasting product.

In addition, we can design and manufacture special sliding products, according to special designs and particular production needs.

ELEMENTOS DE GUIADO SLIDING ELEMENTS

ÍNDICE INDEX

97

**MONTAJE NORMALIZADO
PORTAMATRIZ**
DIE SET STANDARD ASSEMBLY

98

PORTAMATRICES SR
DIE SET SR

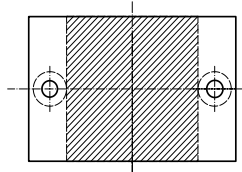

100

PORTAMATRICES SRA
DIE SET SRA

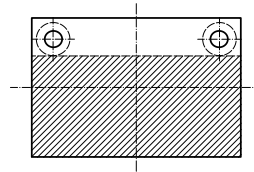

102

PORTAMATRICES SRD
DIE SET SRD

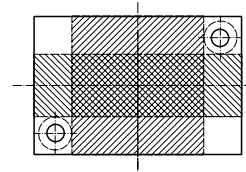

104

PORTAMATRICES SR-4
DIE SET SR-4

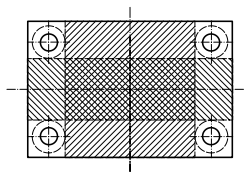

106

COLUMNA GUÍA CIS
GUIDE PILLAR CIS



DIN 9825 - ISO 9182-2

107

COLUMNA GUÍA CIN
GUIDE PILLAR CIN



-

108

COLUMNA GUÍA CIAF
GUIDE PILLAR CIAF



DIN 9825 - ISO 9182-2

109

COLUMNA GUÍA CPC
GUIDE PILLAR CPC



-

110

COLUMNA GUÍA CRN
GUIDE PILLAR CRN



-

111

COLUMNA GUÍA CRT
GUIDE PILLAR CRT



-

112

COLUMNA GUÍA CIW
GUIDE PILLAR CIW



DIN 9833

113

COLUMNA GUÍA CIWH
GUIDE PILLAR CIWH



DIN 9833

114

COLUMNA GUÍA CFW
GUIDE PILLAR CFW



DIN 9833

115

COLUMNA GUÍA CFWH
GUIDE PILLAR CFWH



DIN 9833

116

**COLUMNA GUÍA
CON VALONA CE**
GUIDE PILLAR WITH COLLAR CE



-

117

COLUMNA GUÍA CON VALONA CEN
GUIDE PILLAR WITH COLLAR CEN



-

118

COLUMNA GUÍA CON VALONA CEI
GUIDE PILLAR WITH COLLAR CEI



-

119

COLUMNA GUÍA CON VALONA CEJ
GUIDE PILLAR WITH COLLAR CEJ



DIN 9825-4 - ISO 9182-5

120

COLUMNA GUÍA CÓNICA COCI
CONICAL GUIDE PILLAR COCI



DIN 9825-4 - ISO 9182-5

121

CASQUILLO CÓNICO CACI
CONICAL BUSH CACI



DIN 9825-4 - ISO 9182-5

122

COLUMNA GUÍA CON VALONA CEV
GUIDE PILLAR WITH COLLAR CEV



-

123

COLUMNA DOBLE DIÁMETRO CDD
GUIDE PILLAR DOUBLE DIAMETER CDD



-

124

COLUMNA GUÍA CDDN
GUIDE PILLAR CDDN



-

125

CASQUILLO GUÍA CAC - CBC
GUIDE BUSH CAC - CBC



-

126

CASQUILLO GUÍA CAV - CBV
GUIDE BUSH CAV - CBV



-

127

CASQUILLO GUÍA CAL - CBL
GUIDE BUSH CAL - CBL



-

128

CASQUILLO GUÍA CAA
GUIDE BUSH CAA



-

129

CASQUILLO GUÍA CACN - CBCN
GUIDE BUSH CACN - CBCN



-

130

CASQUILLO GUÍA CAVN - CBVN
GUIDE BUSH CAVN - CBVN



-

131

CASQUILLO GUÍA CAEC - CBEC - CABEC
GUIDE BUSH CAEC - CBEC - CABEC



-

132

CASQUILLO GUÍA CAEM - CBEM - CABEM
GUIDE BUSH CAEM - CBEM - CABEM



-

133

CASQUILLO GUÍA
CAEV - CBEV - CABEV
GUIDE BUSH
CAEV - CBEV - CABEV



134

CASQUILLO GUÍA
CAEL - CBEL - CABEL
GUIDE BUSH
CAEL - CBEL - CABEL



135

CASQUILLO GUÍA
CAEX - CBEX - CABEX
GUIDE BUSH
CAEX - CBEX - CABEX



136

CASQUILLO GUÍA
CAIC - CABIC - CABRC
GUIDE BUSH CAIC - CABIC - CABRC



ISO 9448-6

137

CASQUILLO GUÍA
CAIV - CABIV - CABRV
GUIDE BUSH
CAIV - CABIV - CABRV



ISO 9448-6

138

CASQUILLO GUÍA
CAIL - CABIL - CABRL
GUIDE BUSH
CAIL - CABIL - CABRL



ISO 9448-6

139

CASQUILLO GUÍA
CASC - CABSC
GUIDE BUSH
CASC - CABSC



ISO 9448-4

140

CASQUILLO GUÍA CASV - CABS
GUIDE BUSH CASV - CABS



ISO 9448-4

141

CASQUILLO GUÍA CASL - CABSL
GUIDE BUSH CASL - CABSL



ISO 9448-4

142

**CASQUILLO GUÍA PARA JAULA
DE BOLAS CJC**
GUIDE BUSH FOR BALL CAGE
CJC



-

143

**CASQUILLO GUÍA PARA JAULA
DE BOLAS CJV**
GUIDE BUSH FOR BALL CAGE
CJV



-

144

**CASQUILLO GUÍA PARA JAULA
DE BOLAS CJL**
GUIDE BUSH FOR BALL CAGE
CJL



-

145

**CASQUILLO GUÍA PARA JAULA
DE BOLAS CJA**
GUIDE BUSH FOR BALL CAGE
CJA



-

146

**CASQUILLO GUÍA PARA JAULA
DE BOLAS CJCN**
GUIDE BUSH FOR BALL CAGE
CJCN



-

147

**CASQUILLO GUÍA PARA JAULA
DE BOLAS CJVN**
GUIDE BUSH FOR BALL CAGE
CJVN



-

148

**CASQUILLO PARA JAULA
DE BOLAS SUSPENDIDA CJSN**
GUIDE BUSH FOR HANGING
BALL CJSN



-

149

CASQUILLO GUÍA PARA JAULA DE BOLAS CJIC
GUIDE BUSH FOR BALL CAGE CJIC



ISO 9448-7

150

CASQUILLO GUÍA PARA JAULA DE BOLAS CJIM
GUIDE BUSH FOR BALL CAGE CJIM



ISO 9448-7

151

CASQUILLO GUÍA PARA JAULA DE BOLAS CJIV
GUIDE BUSH FOR BALL CAGE CJIV



ISO 9448-7

152

CASQUILLO GUÍA PARA JAULA DE BOLAS CJIL
GUIDE BUSH FOR BALL CAGE CJIL



ISO 9448-7

153

CASQUILLO GUÍA PARA JAULA DE BOLAS CJIX
GUIDE BUSH FOR BALL CAGE CJIX



ISO 9448-7

154

CASQUILLO GUÍA PARA JAULA DE BOLAS CJSC
GUIDE BUSH FOR BALL CAGE CJSC



DIN 9831 / ISO 9448-5

155

CASQUILLO GUÍA PARA JAULA DE BOLAS CJSV
GUIDE BUSH FOR BALL CAGE CJSV



DIN 9831 / ISO 9448-5

156

CASQUILLO GUÍA PARA JAULA DE BOLAS CJSL
GUIDE BUSH FOR BALL CAGE CJSL



DIN 9831 - ISO 9448-5

157

JAULA DE BOLAS JB - JBB
BALL CAGE JB - JBB



158

JAULA DE BOLAS JBA - JBBA
BALL CAGE JBA - JBBA



159

JAULA DE BOLAS JBL - JBBL
BALL CAGE JBL - JBBL



160

JAULA DE BOLAS JBS
BALL CAGE JBS



161

JAULA DE BOLAS JBD
BALL CAGE JBD



162

JAULA DE BOLAS JBI
BALL CAGE JBI



163

JAULA DE BOLAS SUSPENDIDA JBIS
HANGING BALL CAGE JBIS



164

JAULA DE RODILLOS JBR
ROLLER CAGE JBR



165

MUELLE PARA JAULA DE BOLAS MJB
SPRING FOR BALL CAGE MJB



-

166

CASQUILLO DE BOLAS CON VALONA CBOV
BALL GUIDE BUSH WITH COLLAR CBOV



-

167

CASQUILLO DE BOLAS CON VALONA CBOM
BALL GUIDE BUSH WITH COLLAR CBOM



-

168

CASQUILLO DE BOLAS LISO CBOL
BALL GUIDE BUSH CBOL



-

169

CASQUILLO GUÍA CBGC
GUIDE BUSH CBGC



-

170

CASQUILLO GUÍA CBGV
GUIDE BUSH CBGV



-

171

CASQUILLO GUÍA CBGL
GUIDE BUSH CBGL



-

172

CASQUILLO GUÍA BGW
GUIDE BUSH BGW



DIN 9834

173

CASQUILLO GUÍA BGP
GUIDE BUSH BGP



AFNOR

174

CASQUILLO GUÍA BGN
GUIDE BUSH BGN



-

175

CASQUILLO GUÍA BGO
GUIDE BUSH BGO



ISO 9448-4

176

CASQUILLO GUÍA BGT
GUIDE BUSH BGT



ISO 9448-4

177

CASQUILLO GUÍA BGF
GUIDE BUSH BGF



-

178

CASQUILLO GUÍA CBP
GUIDE BUSH CBP



-

179

CASQUILLO GUÍA BGA
GUIDE BUSH BGA



-

180

CASQUILLO GUÍA BGB
GUIDE BUSH BGB



-

181

**ARANDELA AUTOLUBRICADA
ABG**
OILLESS WASHER ABG



-

182

CASQUILLO AUTOLUBRICADO A
SELF-LUBRICATING BUSH A



ISO 2795

184

CASQUILLO AUTOLUBRICADO B
SELF-LUBRICATING BUSH B



ISO 2795

185

**CASQUILLO AUTOLUBRICADO
GLYB**
SELF-LUBRICATING BUSH GLYB



DIN 1494 - ISO 3548

186

**CASQUILLO AUTOLUBRICADO
GLY**
SELF-LUBRICATING BUSH GLY



DIN 1494 - ISO 3547

188

**ARANDELA PARA COLUMNA
RTE - RTI**
WASHER FOR PILLAR RTE - RTI



-

189

BRIDA DE RETENCIÓN BRC
RETAINING CLAMP BRC



-

190

**ANILLO RETENCIÓN
COLUMNA ANR**
RETAINING RING FOR PILLAR
ANR



-

191

**BRIDA RETENCIÓN COLUMNA
BRCO**
RETAINING CLAMP FOR PILLAR
BRCO



AFNOR

192

BRIDA DE RETENCIÓN BRE 5
RETAINING CLAMP BRE 5



-

192

BRIDA DE RETENCIÓN BRE 6
RETAINING CLAMP BRE 6



-

192

BRIDA DE RETENCIÓN BRE 8
RETAINING CLAMP BRE 8



-

192

BRIDA DE RETENCIÓN BRE A8
RETAINING CLAMP BRE A8



-

193

BRIDA DE RETENCIÓN BREI 6
RETAINING CLAMP BREI 6



-

193

BRIDA DE RETENCIÓN BREI 8
RETAINING CLAMP BREI 8



-

193

BRIDA DE RETENCIÓN BREI 8P
RETAINING CLAMP BREI 8P



-



193

BRIDA DE RETENCIÓN BREI 14
RETAINING CLAMP BREI 14

-

193

BRIDA DE RETENCIÓN BREI 23
RETAINING CLAMP BREI 23

-

194

BRIDA DE RETENCIÓN BRW
RETAINING CLAMP BRW

DIN 9832

194

BRIDA DE RETENCIÓN BRM
RETAINING CLAMP BRM

-

195

**BRIDA DE RETENCIÓN
BRN - BRT**
RETAINING CLAMP BRN - BRT

-

196

BRIDA MECANIZADA BRO
TOE CLAMP BRO

-

197

BRIDA PARA CASQUILLO BRCA
CLAMP FOR BUSH BRCA

AFNOR

198

BRIDA PARA CASQUILLO BRCC
CLAMP FOR BUSH BRCC

-

199

TORNILLO TCI - TCO - TCC
SCREW TCI - TCO - TCC

-

200

PLACA PBGF
WEAR PLATE PBGF

-

201

PLACA PBGL
WEAR PLATE PBGL

-

202

PLACA PBGN
WEAR PLATE PBGN

-

203

PLACA PBGG - PACG
WEAR PLATE PBGG - PACG

-

204

PLACA PBGV - PACV
WEAR PLATE PBGV - PACV

VDI 3357

205

PLACA PSTV
WEAR PLATE PSTV

VDI 3357

206

PLACA PBGW - PSTW - PACW
WEAR PLATE PBGW - PSTW -
PACW

VDI 3357

207

PLACA PBGZ
WEAR PLATE PBGZ



VDI 3357

208

PLACA PBGH - PACH
WEAR PLATE PBGH - PACH



-

210

PLACA PBGE
WEAR PLATE PBGE



-

212

PLACA PBGR - PACR
WEAR PLATE PBGR - PACR



-

213

PLACÓN PAGW
PLATE PAGW

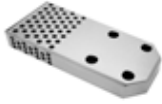

VDI 3387

214

ESCUADRA EBGW
ANGULAR GUIDE EBGW



-

215

ESCUADRA EBGW
ANGULAR GUIDE EBGW



-

216

GUÍA "V" GACH
"V" DRIVER GACH



VDI 3357

217

GUÍA "V" GBGM
"V" DRIVER GBGM



VDI 3357

218

GUÍA "V" GBGH
"V" DRIVER GBGH



-

219

GUÍA "V" GACM
"V" DRIVER GACM



-

220

GUÍA CARRO GBGO - GACO
CAM WEAR PLATE GBGO - GACO

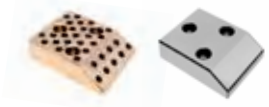

-

221

GUÍA CARRO GBGW - GACW
CAM WEAR PLATE GBGW - GACW



VDI 3357



MONTAJE NORMALIZADO PORTAMATRIZ DIE SET STANDARD ASSEMBLY

EL montaje normalizado de los portamatrices se hace con la columna CIS. La siguiente tabla representa las distintas opciones de casquillo y su forma de pedido. Para columnas y casquillos distintos al normalizado, indicar código en pedido.

Standard assembly of die sets with CIS pillar. The following chart represents the different bush options and the way to order. For alternate pillars and bushes, specify code in your order.

MATERIAL CASQUILLO BUSH MATERIAL	ESTÁNDAR (Incluye placas C1 y C2) STANDARD (C1 and C2 plates included)		ESTÁNDAR + PLACA INTERMEDIA (Incluye placas C1, C2 y C3) STANDARD + INTERMEDIATE PLATE (C1, C2 and C3 plates included)	
	Código casquillo Bush Code	Forma de pedido How to order	Código casquillo Bush Code	Forma de pedido How to order
Acero / Steel	CAV	Código / Code + AC	CAV + CAC	Código / Code + AC + PI
Bronce + grafito / Bronze + graphite	CBGV	Código / Code + BG	CBGV + CBGC	Código / Code + BG + PI
Bronce / Bronze	CBV	Código / Code + BR	CBV + CBC	Código / Code + BR + PI
Para jaula de bolas / For ball cage	CJV	Código / Code + JB	CJV + CJC	Código / Code + JB + PI

PORTAMATRICES SR DIE SET SR

Material: 1.1730

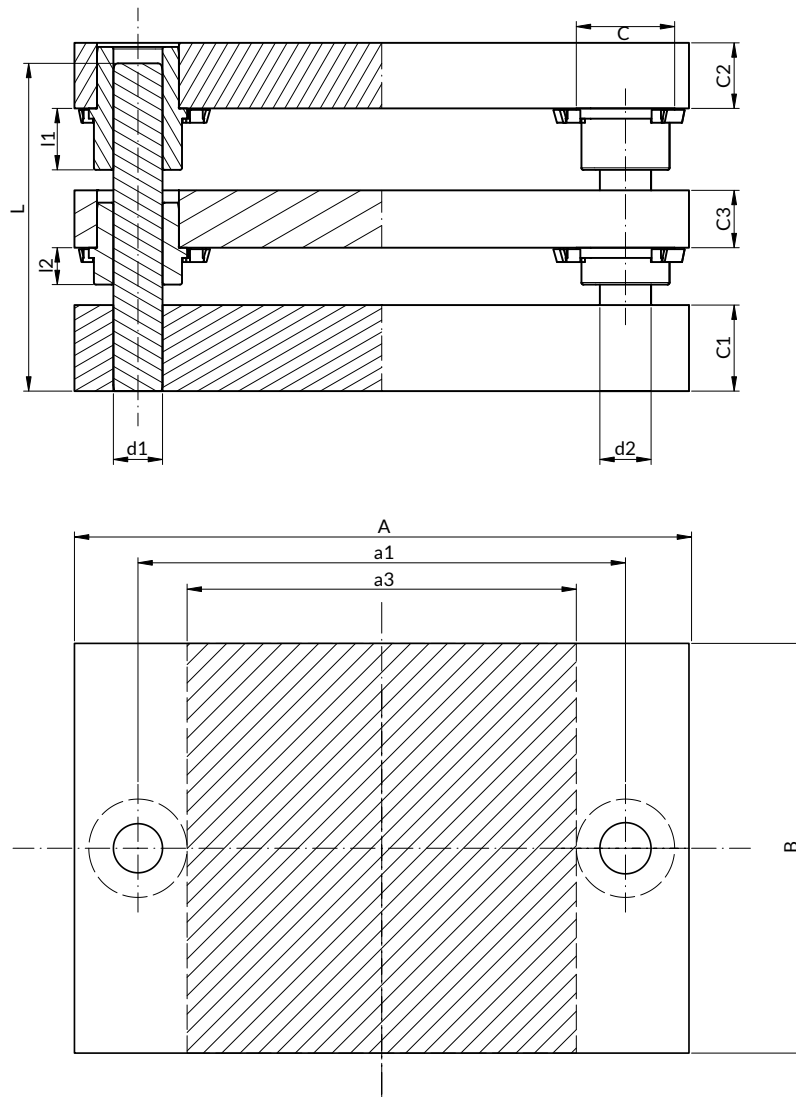

Se fabrican todo tipo de medidas y materiales bajo pedido
We also produce other dimensions and materials

Código Code	Dimensiones / Dimensions				Espesores / Thicknesses				Col. / Casq.				
	A	B	a ₁	a ₃	C ₁	C ₂	C ₃	d ₁	d ₂	L	C	l ₁	l ₂
SR 1	175	65	125	85	32	27	18	18	19	130	40	35	18
SR 2	200	65	150	110	32	27	18	18	19	130	40	35	18
SR 3	225	80	163	135	32	27	23	18	19	140	40	35	18
SR 4	250	80	188	160	32	27	23	18	19	140	40	35	18
SR 5	225	100	163	115	37	32	23	24	25	140	48	45	18
SR 6	250	100	188	140	37	32	23	24	25	140	48	45	18
SR 7	285	100	223	175	37	32	23	24	25	140	48	45	18
SR 8	325	100	263	215	37	32	23	24	25	140	48	45	18
SR 12	235	125	199	125	37	32	23	24	25	140	48	45	18
SR 13	275	125	213	165	37	32	23	24	25	140	48	45	18
SR 14	325	125	263	215	37	32	23	24	25	140	48	45	18
SR 15	365	125	313	255	37	32	23	24	25	140	48	45	18
SR 18	275	165	213	165	37	32	23	24	25	140	48	45	18
SR 20	325	165	263	215	37	32	23	24	25	140	48	45	18

Continúa en la siguiente página...
Continue next page...

Forma de pedido: Ver Montaje Normalizado (pág. 97)
How to order: See Standard Assembly (page 97)

Código Code	Dimensiones / Dimensions				Espesores / Thicknesses			Col. / Casq.					
	A	B	a ₁	a ₃	C ₁	C ₂	C ₃	d ₁	d ₂	L	C	l ₁	l ₂
SR 22	400	165	323	265	37	32	28	30	32	160	58	50	18
SR 23	450	165	373	315	37	32	28	30	32	160	58	50	18
SR 28	350	200	273	215	42	32	28	30	32	160	58	50	18
SR 29	400	200	323	265	42	32	28	30	32	160	58	50	18
SR 30	450	200	373	315	42	32	28	30	32	160	58	50	18
SR 31	500	200	423	365	42	32	28	30	32	160	58	50	18
SR 43	450	250	362	290	42	42	32	40	42	180	72	50	18
SR 44	500	250	412	340	42	42	32	40	42	180	72	50	18
SR 45	550	250	462	390	42	42	32	40	42	180	72	50	18
SR 46	600	250	512	440	42	42	32	40	42	180	72	50	18
SR 54	500	300	412	340	47	42	32	40	42	180	72	50	18
SR 55	550	300	462	390	47	42	32	40	42	180	72	50	18
SR 56	600	300	512	440	47	42	32	40	42	180	72	50	18
SR 57	650	300	562	490	47	42	32	40	42	180	72	50	18
SR 61	500	350	412	340	47	42	32	40	42	180	72	50	18
SR 62	550	350	462	390	47	42	32	40	42	180	72	50	18
SR 63	600	350	512	440	47	42	32	40	42	180	72	50	18
SR 64	650	350	562	490	47	42	32	40	42	180	72	50	18
SR 65	700	350	612	540	47	42	32	40	42	180	72	50	18
SR 67	500	400	412	340	47	42	32	40	42	180	72	50	18
SR 68	600	400	512	440	47	42	32	40	42	180	72	50	18
SR 69	700	400	612	540	47	42	32	40	42	180	72	50	18
SR 70	800	400	712	640	47	42	32	40	42	180	72	50	18
SR 71	500	450	412	340	57	47	32	40	42	200	72	50	18
SR 72	600	450	512	440	57	47	32	40	42	200	72	50	18
SR 73	700	450	612	540	57	47	32	40	42	200	72	50	18
SR 74	800	450	712	640	57	47	32	40	42	200	72	50	18
SR 76	600	500	512	440	57	47	32	40	42	225	72	50	18
SR 77	700	500	612	540	57	47	32	40	42	225	72	50	18
SR 78	800	500	712	640	57	47	32	40	42	225	72	50	18
SR 79	900	500	812	740	57	47	32	40	42	225	72	50	18
SR 80	1000	500	912	840	57	47	32	40	42	225	72	50	18
SR 81	700	600	602	520	57	47	38	50	52	225	82	55	18
SR 82	800	600	702	620	57	47	38	50	52	225	82	55	18
SR 83	900	600	802	720	57	47	38	50	52	225	82	55	18
SR 84	1000	600	902	820	57	47	38	50	52	225	82	55	18
SR 85	1200	600	1102	1020	57	47	38	50	52	225	82	55	18

Forma de pedido: Ver Montaje Normalizado (pág. 97)
How to order: See Standard Assembly (page 97)

PORTAMATRICES SRA DIE SET SRA

Material: 1.1730

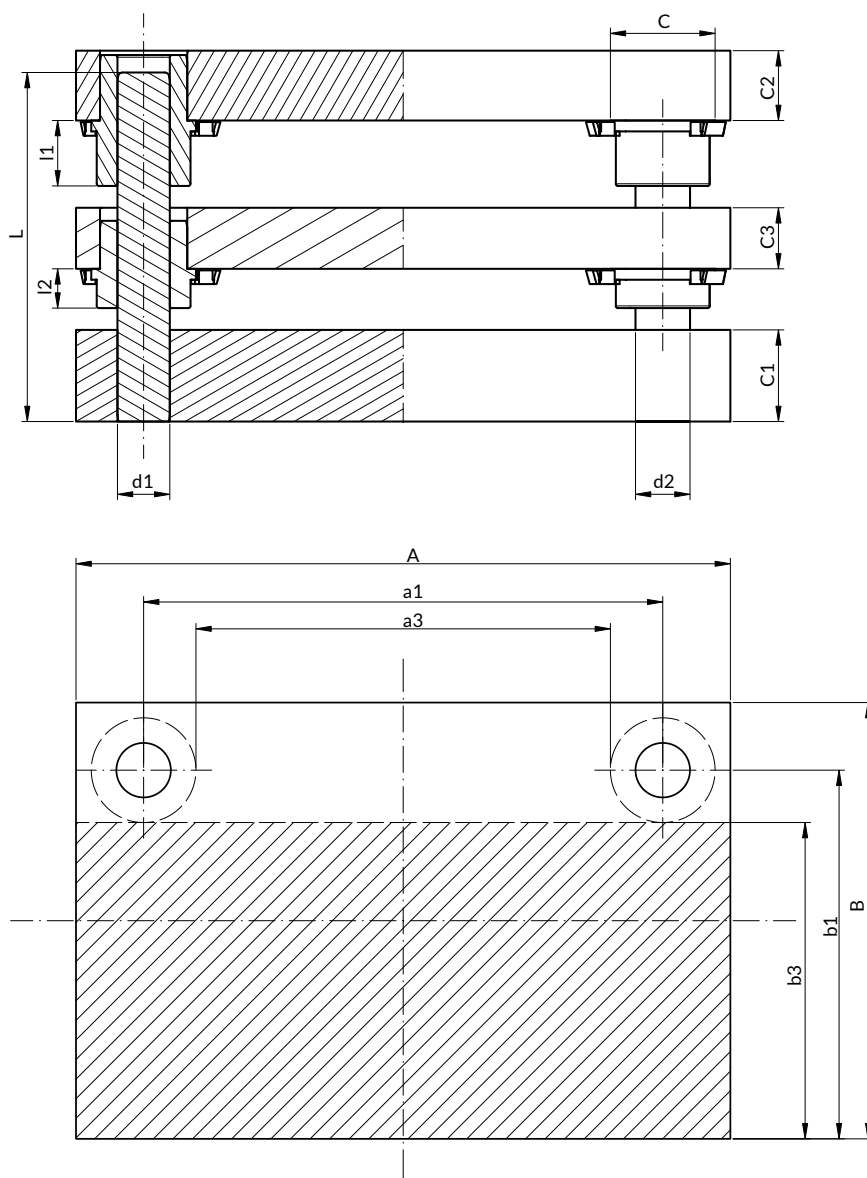

Se fabrican todo tipo de medidas y materiales bajo pedido
We also produce other dimensions and materials

Código Code	Dimensiones / Dimensions							Espesores / Thicknesses			Col. / Casq.				
	A	B	a ₁	a ₃	b ₁	b ₂	b ₃	C ₁	C ₂	C ₃	d	L	C	l ₁	l ₂
SRA 9	150	125	100	57	100	90	80	32	27	18	19	130	38	35	18
SRA 10	178	125	125	87	100	90	80	32	27	18	19	130	38	35	18
SRA 16	200	165	138	90	134	121	110	37	32	23	25	140	48	45	18
SRA 17	250	165	188	140	134	121	110	37	32	23	25	140	48	45	18
SRA 19	300	165	238	190	134	121	110	37	32	23	25	140	48	45	18
SRA 21	350	165	288	240	134	121	110	37	32	23	25	140	48	45	18
SRA 24	200	165	123	65	134	121	110	37	32	23	25	140	48	45	18
SRA 25	225	200	148	90	161	145	132	42	32	28	30	160	58	50	18
SRA 26	250	200	173	115	161	145	132	42	32	28	30	160	58	50	18
SRA 27	300	200	223	165	161	145	132	42	32	28	30	160	58	50	18
SRA 28	350	200	273	215	161	145	132	42	32	28	30	160	58	50	18

Continúa en la siguiente página...
Continue next page...

Forma de pedido: Ver Montaje Normalizado (pág. 97)
How to order: See Standard Assembly (page 97)

Código Code	Dimensiones / Dimensions							Espesores / Thicknesses			Col. / Casq.				
	A	B	a ₁	a ₃	b ₁	b ₂	b ₃	C ₁	C ₂	C ₃	d	L	C	l ₁	l ₂
SRA 32	225	225	148	90	186	170	157	42	32	38	30	160	58	50	18
SRA 33	250	225	173	115	186	170	157	42	32	38	30	160	58	50	18
SRA 34	275	225	198	140	186	170	157	42	32	38	32	160	58	50	18
SRA 35	300	225	223	165	186	170	157	42	32	38	32	160	58	50	18
SRA 36	350	225	273	215	186	170	157	42	32	38	32	160	58	50	18
SRA 38	250	250	173	115	211	195	182	42	37	28	32	180	58	50	18
SRA 39	275	250	198	140	211	195	182	42	37	28	32	180	58	50	18
SRA 40	300	250	223	165	211	195	182	42	37	28	32	180	58	50	18
SRA 41	350	250	273	215	211	195	182	42	37	28	32	180	58	50	18
SRA 42	400	250	312	240	206	186	170	47	42	32	40	180	72	50	18
SRA 43	450	250	362	290	206	186	170	47	42	32	40	180	72	50	18
SRA 47	300	275	212	140	231	211	195	47	42	32	40	180	72	50	18
SRA 48	350	275	262	190	231	211	195	47	42	32	40	180	72	50	18
SRA 49	400	275	312	240	231	211	195	47	42	32	40	180	72	50	18
SRA 50	450	275	362	290	231	211	195	47	42	32	40	180	72	50	18
SRA 51	350	300	262	190	256	236	220	47	42	32	40	180	72	50	18
SRA 52	400	300	312	240	256	236	220	47	42	32	40	180	72	50	18
SRA 53	450	300	362	290	256	236	220	47	42	32	40	180	72	50	18
SRA 59	400	350	312	240	306	286	270	47	42	32	40	180	72	50	18
SRA 60	450	350	362	290	306	286	270	47	42	32	40	180	72	50	18
SRA 61	500	350	412	340	306	286	270	47	42	32	40	180	72	50	18
SRA 66	450	400	362	290	356	336	320	47	42	32	42	180	72	50	18
SRA 67	500	400	412	340	356	336	320	47	42	32	42	180	72	50	18
SRA 68	600	400	512	440	356	336	320	47	42	32	42	180	72	50	18
SRA 71	500	450	412	340	406	386	370	57	47	32	42	200	72	50	18
SRA 72	600	450	512	440	406	386	370	57	47	32	42	200	72	50	18
SRA 73	700	450	612	540	406	386	370	57	47	32	42	200	72	50	18
SRA 75	500	500	412	340	456	436	420	57	47	32	42	225	72	50	18
SRA 76	600	500	512	440	456	436	420	57	47	32	42	225	72	50	18
SRA 77	700	500	612	540	456	436	420	57	47	32	42	225	72	50	18
SRA 78	800	500	712	650	456	436	420	57	47	32	42	225	72	50	18
SRA 80	600	600	502	420	551	526	510	57	47	38	50	225	82	55	18
SRA 81	700	600	602	520	551	526	510	57	47	38	50	225	82	55	18
SRA 82	800	600	702	620	551	526	510	57	47	38	50	225	82	55	18
SRA 83	900	600	802	720	551	526	510	57	47	38	50	225	82	55	18

Forma de pedido: Ver Montaje Normalizado (pág. 97)
How to order: See Standard Assembly (page 97)

PORTAMATRICES SRD DIE SET SRD

Material: 1.1730

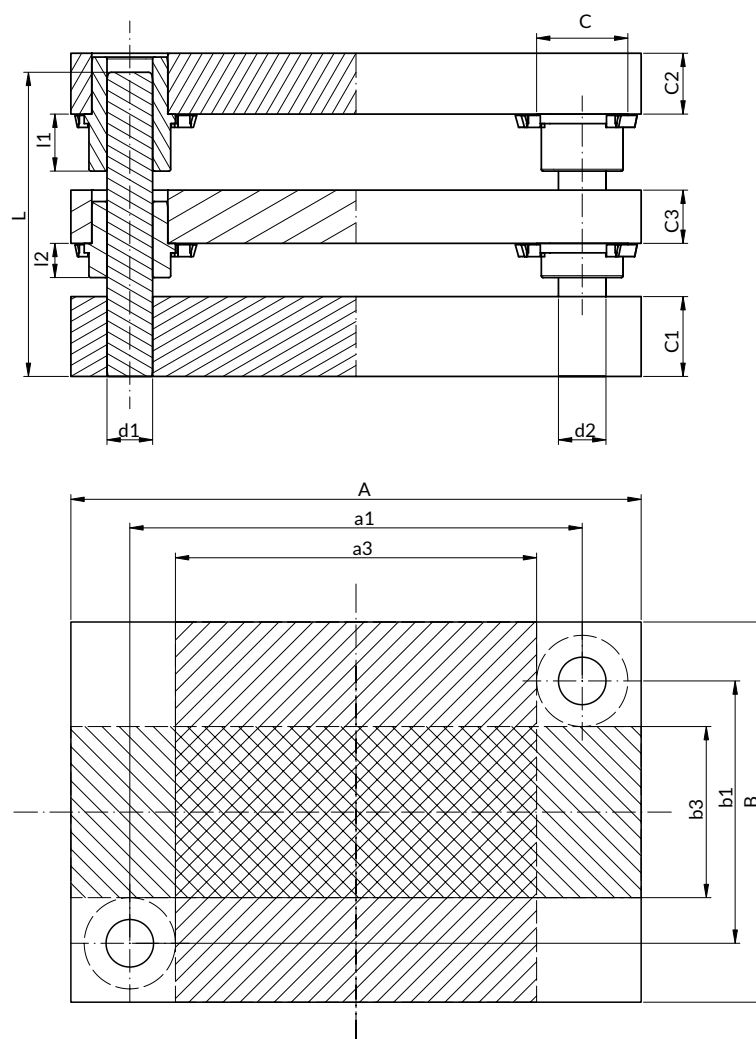

Se fabrican todo tipo de medidas y materiales bajo pedido
We also produce other dimensions and materials

Código Code	Dimensiones / Dimensions							Espesores / Thicknesses			Col. / Casq.					
	A	B	a ₁	a ₃	b ₁	b ₂	b ₃	C ₁	C ₂	C ₃	d ₁	d ₂	L	C	l ₁	l ₂
SRD 9	150	125	100	60	75	56	35	32	27	18	18	19	130	34	25	18
SRD 11	200	125	150	110	75	56	35	32	27	18	18	19	130	34	25	18
SRD 16	200	165	138	90	103	78	55	37	32	23	24	25	140	48	45	18
SRD 17	250	165	188	140	103	78	55	37	32	23	24	25	140	48	45	18
SRD 19	300	165	238	190	103	78	55	37	32	23	24	25	140	48	45	18
SRD 24	200	200	123	65	123	92	65	42	32	28	30	32	160	58	50	18
SRD 25	225	200	148	90	123	92	65	42	32	28	30	32	160	58	50	18
SRD 26	250	200	173	115	123	92	65	42	32	28	30	32	160	58	50	18
SRD 27	300	200	223	165	123	92	65	42	32	28	30	32	160	58	50	18
SRD 28	350	200	273	216	123	92	65	42	32	28	30	32	160	58	50	18
SRD 32	225	225	148	90	148	117	90	42	32	28	30	32	160	58	50	18
SRD 33	250	225	173	115	148	117	90	42	32	28	30	32	160	58	50	18
SRD 35	300	225	223	165	148	117	90	42	32	28	30	32	160	58	50	18
SRD 36	350	225	273	210	148	117	90	42	32	28	30	32	160	58	50	18
SRD 37	400	225	323	165	148	117	90	42	32	28	30	32	160	58	50	18

Continúa en la siguiente página...
Continue next page...

Forma de pedido: Ver Montaje Normalizado (pág. 97)
How to order: See Standard Assembly (page 97)

Código Code	Dimensiones / Dimensions							Espesores/Thicknesses			Col. / Casq.					
	A	B	a ₁	a ₃	b ₁	b ₂	b ₃	C ₁	C ₂	C ₃	d ₁	d ₂	L	C	I ₁	I ₂
SRD 38	250	250	173	116	173	142	115	42	37	28	30	32	180	58	50	18
SRD 40	300	250	223	165	173	142	115	42	37	28	30	32	180	58	50	18
SRD 41	350	250	373	215	173	142	115	42	37	28	30	32	180	58	50	18
SRD 42	400	250	312	240	162	121	90	47	42	32	40	42	180	72	50	18
SRD 43	450	250	362	290	162	121	90	47	42	32	40	42	180	72	50	18
SRD 44	500	250	412	340	162	121	90	47	42	32	40	42	180	72	50	18
SRD 46	600	250	512	440	162	121	90	47	42	32	40	42	180	72	50	18
SRD 51	350	300	262	190	212	171	140	47	42	32	40	42	180	72	50	18
SRD 52	400	300	312	240	212	171	140	47	42	32	40	42	180	72	50	18
SRD 53	450	300	362	290	212	171	140	47	42	32	40	42	180	72	50	32
SRD 54	500	300	412	340	212	171	140	47	42	32	40	42	180	72	50	32
SRD 56	600	300	512	440	212	171	140	47	42	32	40	42	180	72	50	18
SRD 59	400	350	312	240	262	221	190	47	18	32	40	42	180	72	50	18
SRD 60	450	350	362	290	262	221	190	47	18	32	40	42	180	72	50	18
SRD 61	500	350	412	340	262	221	190	47	42	32	40	42	180	72	50	18
SRD 63	600	350	512	440	262	221	190	47	42	32	40	42	180	72	50	18
SRD 65	700	350	612	540	262	221	190	47	42	32	40	42	180	72	50	18
SRD 66	450	400	363	290	312	271	240	47	42	32	40	42	180	72	50	18
SRD 67	500	400	412	340	312	271	240	47	42	32	40	42	180	72	50	18
SRD 68	600	400	512	440	312	271	240	47	42	32	40	42	180	72	50	18
SRD 69	700	400	612	540	312	271	240	47	42	32	40	42	180	72	50	18
SRD 70	800	400	712	640	312	271	240	47	42	32	40	42	180	72	50	18
SRD 71	500	450	412	340	362	321	290	57	47	32	40	42	200	72	50	18
SRD 72	600	450	512	440	362	321	290	57	47	32	40	42	200	72	50	18
SRD 73	700	450	612	540	362	321	290	57	47	32	40	42	200	72	50	18
SRD 74	800	450	712	640	362	321	290	57	47	32	40	42	200	72	50	18
SRD 76	600	500	512	440	412	371	340	57	47	32	40	42	225	72	50	18
SRD 77	700	500	612	540	412	371	340	57	47	32	40	42	225	72	50	18
SRD 78	800	500	712	640	412	371	340	57	47	32	40	42	225	72	50	18
SRD 79	900	500	812	740	412	371	340	57	47	32	40	42	225	72	50	18
SRD 81	700	600	602	520	502	451	420	57	47	38	50	52	225	82	55	18
SRD 82	800	600	702	620	502	451	420	57	47	38	50	52	225	82	55	18
SRD 83	900	600	802	720	502	451		57	47	38	50	52	225	82	55	18

Forma de pedido: Ver Montaje Normalizado (pág. 97)
How to order: See Standard Assembly (page 97)

PORTAMATRICES SR-4 DIE SET SR-4

Material: 1.1730

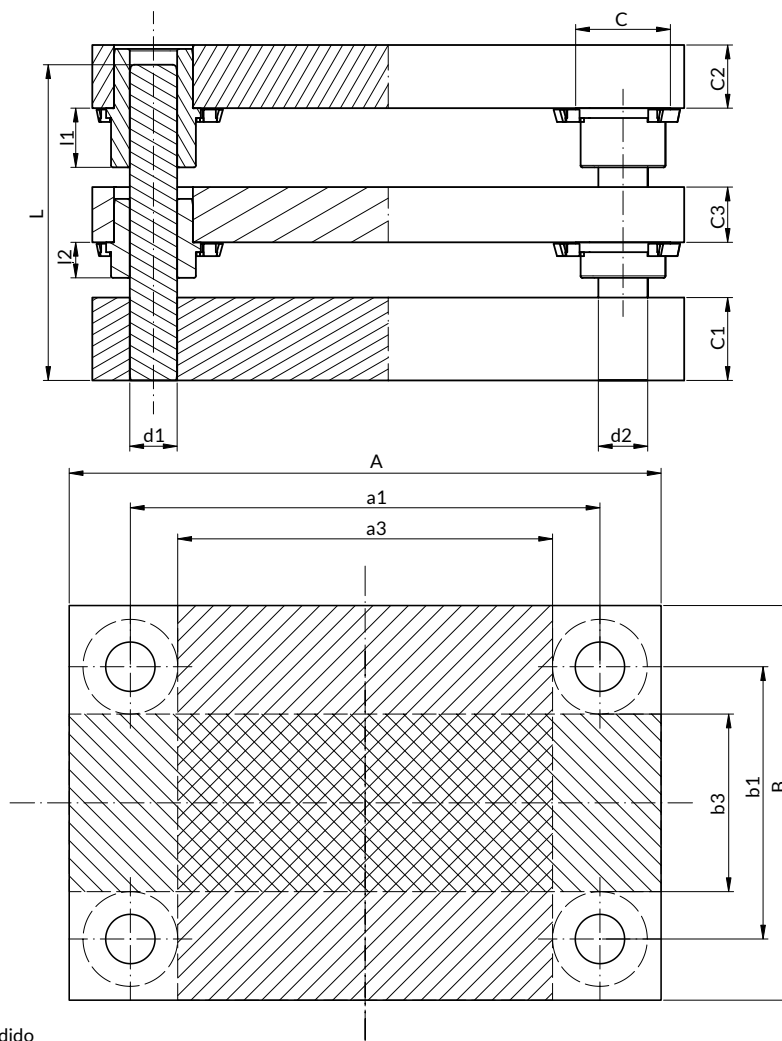

Se fabrican todo tipo de medidas y materiales bajo pedido
We also produce other dimensions and materials

Código Code	Dimensiones / Dimensions							Espesores / Thicknesses			Col. / Casq.					
	A	B	a ₁	a ₃	b ₁	b ₂	b ₃	C ₁	C ₂	C ₃	d ₁	d ₂	L	C	l ₁	l ₂
SR-49	150	125	100	60	75	56	35	32	27	18	18	19	130	38	35	16
SR-411	200	125	150	110	75	56	35	32	27	18	18	19	130	38	35	16
SR-416	200	165	138	90	103	78	55	37	32	23	24	25	140	48	45	18
SR-417	250	165	188	140	103	78	55	37	32	23	24	25	140	48	45	18
SR-419	300	165	238	190	103	78	55	37	32	23	24	25	140	48	45	18
SR-421	350	165	288	240	103	78	55	37	32	23	24	25	140	48	45	18
SR-425	225	200	163	115	138	113	90	42	32	23	24	25	160	47	45	18
SR-426	250	200	188	140	138	113	90	42	32	23	24	25	160	47	45	18
SR-427	300	200	238	190	138	113	90	42	32	34	24	25	160	47	45	18
SR-428	350	200	273	215	123	92	65	42	32	28	30	32	160	58	50	18
SR-429	400	200	323	265	123	92	65	42	32	28	30	32	160	58	50	18
SR-430	450	200	373	315	123	92	65	42	32	28	30	32	160	58	50	18
SR-440	300	250	223	165	173	142	115	42	37	28	30	32	180	58	50	18
SR-441	350	250	273	215	173	142	115	42	37	28	30	32	180	58	50	18
SR-442	400	250	323	265	173	142	115	42	37	28	30	32	180	58	50	18
SR-443	450	250	373	315	173	142	115	42	37	28	30	32	180	58	50	18
SR-444	500	250	423	365	173	142	115	42	37	28	30	32	180	58	50	18

Continúa en la siguiente página...
Continue next page...

Forma de pedido: Ver Montaje Normalizado (pág. 97)
How to order: See Standard Assembly (page 97)

Código Code	Dimensiones / Dimensions							Espesores / Thicknesses			Col. / Casq.					
	A	B	a ₁	a ₃	b ₁	b ₂	b ₃	C ₁	C ₂	C ₃	d ₁	d ₂	L	C	l ₁	l ₂
SR-451	350	300	273	215	223	192	165	42	37	28	30	32	180	58	50	18
SR-452	400	300	323	265	223	192	165	42	37	28	30	32	180	58	50	18
SR-453	450	300	373	315	223	192	165	42	37	28	30	32	180	58	50	18
SR-454	500	300	423	365	223	192	165	42	37	28	30	32	180	58	50	18
SR-456	600	300	523	465	223	192	165	42	37	28	30	32	180	58	50	18
SR-458	700	300	623	565	223	192	165	42	37	28	30	32	180	58	50	18
SR-459	400	350	312	240	262	221	190	47	42	32	40	42	180	72	50	18
SR-460	450	350	362	290	262	221	190	47	42	32	40	42	180	72	50	18
SR-461	500	350	412	340	262	221	190	47	42	32	40	42	180	72	50	18
SR-463	600	350	512	440	262	221	190	47	42	32	40	42	180	72	50	18
SR-465	700	350	612	540	262	221	190	47	42	32	40	42	180	72	50	18
SR-466	450	400	362	290	312	271	240	47	42	32	40	42	180	72	50	18
SR-467	500	400	412	340	312	271	240	47	42	32	40	42	180	72	50	18
SR-468	600	400	512	440	312	271	240	47	42	32	40	42	180	72	50	18
SR-469	700	400	612	540	312	271	240	47	42	32	40	42	180	72	50	18
SR-470	800	400	712	640	312	271	240	47	42	32	40	42	180	72	50	18
SR-471	500	450	412	340	362	321	290	57	47	32	40	42	200	72	50	18
SR-472	600	450	512	440	362	321	290	57	47	32	40	42	200	72	50	18
SR-473	700	450	612	540	362	321	290	57	47	32	40	42	200	72	50	18
SR-474	800	450	712	640	362	321	290	57	47	32	40	42	200	72	50	18
SR-476	600	500	512	440	412	371	340	57	47	32	40	42	225	72	50	18
SR-477	700	500	612	540	412	371	340	57	47	32	40	42	225	72	50	18
SR-478	800	500	712	640	412	371	340	57	47	32	40	42	225	72	50	18
SR-479	900	500	812	740	412	371	340	57	47	32	40	42	225	72	50	18
SR-480	1000	500	912	840	412	371	340	57	47	32	40	42	225	72	50	18
SR-481	700	600	602	520	502	450	420	57	47	38	50	52	225	82	55	18
SR-482	800	600	702	620	502	450	420	57	47	38	50	52	225	82	55	18
SR-483	900	600	802	720	502	450	420	57	47	38	50	52	225	82	55	18
SR-484	1000	600	902	820	502	450	420	57	47	38	50	52	225	82	55	18
SR-485	1200	600	1102	1020	502	450	420	57	47	38	50	52	225	82	55	18
SR-487	800	700	702	620	602	550	520	63	53	43	50	52	240	82	55	18
SR-488	900	700	802	720	602	550	520	63	53	43	50	52	240	82	55	18
SR-489	1000	700	902	820	602	550	520	63	53	43	50	52	240	82	55	18
SR-490	1100	700	1002	920	602	550	520	63	53	43	50	52	240	82	55	18
SR-491	1200	700	1102	1020	602	550	520	63	53	43	50	52	240	82	55	18
SR-492	1400	700	1302	1220	602	550	520	63	53	43	50	52	240	82	55	18

Forma de pedido: Ver Montaje Normalizado (pág. 97)
How to order: See Standard Assembly (page 97)

COLUMNA GUÍA CIS GUIDE PILLAR CIS

Material: Acero Cementación / Case Hardened Steel
Dureza / Hardness: 61-63 HRC

STOCK



Norma / Standard: DIN 9825 - ISO 9182-2

D1	L																													
	90	100	112	120	125	130	140	150	160	170	180	190	200	210	220	224	230	240	250	260	270	280	300	315	355	400	450	500		
15	•	•	•	-	•	-	•	-	•	-	•	-	•	-	•	-	•	-	•	-	•	-	•	-	•	-	•	-	•	
16	•	•	•	-	•	-	•	-	•	-	•	-	•	-	•	-	•	-	•	-	•	-	•	-	•	-	•	-	•	
18	-	-	-	•	-	•	•	•	•	•	•	•	•	-	-	•	-	-	-	-	-	-	-	-	-	-	-	-	-	
19	-	•	•	•	•	•	•	•	•	•	•	•	•	-	-	•	-	-	-	•	-	-	-	-	-	-	-	-	-	
20	-	•	•	-	•	-	•	-	•	-	•	-	•	-	•	-	•	-	-	•	-	-	-	-	-	-	-	-	-	
24	-	-	-	-	•	-	•	•	•	•	•	•	•	•	•	•	•	•	•	•	•	•	•	•	•	•	•	•	•	•
25	-	-	-	-	•	-	•	•	•	•	•	•	•	•	•	•	•	•	•	•	•	•	•	•	•	•	•	•	•	•
30	-	-	-	-	•	-	•	•	•	•	•	•	•	•	•	•	•	•	•	•	•	•	•	•	•	•	•	•	•	•
32	-	-	-	-	•	-	•	•	•	•	•	•	•	•	•	•	•	•	•	•	•	•	•	•	•	•	•	•	•	•

D1	L																												
	160	170	180	190	200	210	220	224	230	240	250	260	270	280	300	315	320	350	355	360	400	450	500	600	700	800			
38	•	-	•	-	•	-	-	•	-	-	•	-	-	•	-	•	-	-	•	-	•	•	•	-	-	-	-	-	
40	•	•	•	•	•	•	•	•	•	•	•	•	•	•	•	•	•	•	•	•	-	•	•	•	-	-	-	-	
42	-	•	•	•	•	•	•	-	•	•	•	•	•	•	•	-	•	•	-	-	•	-	-	-	-	-	-	-	
48	-	-	-	-	•	-	-	•	-	-	•	-	-	•	-	•	-	-	•	-	•	•	•	-	-	-	-	-	
50	-	-	•	•	•	•	•	•	•	•	•	•	•	•	•	•	•	•	•	•	-	•	•	•	-	-	-	-	
52	-	-	•	•	•	•	•	-	•	•	•	•	•	•	•	-	•	•	-	-	•	-	-	-	-	-	-	-	
60	-	-	-	-	-	-	-	-	-	-	•	-	-	•	-	•	-	-	•	-	•	•	•	-	-	-	-	-	
63	-	-	-	-	•	-	•	-	-	•	•	•	-	•	•	•	•	-	•	•	•	•	•	•	-	-	-	-	
80	-	-	-	-	-	-	-	-	-	-	-	-	-	•	•	•	•	-	•	•	•	•	•	•	•	•	•	•	•

Forma de pedido: CIS + D1*L
How to order: CIS + D1*L

COLUMNA GUÍA CIN GUIDE PILLAR CIN

Material: Acero Cementación / Case Hardened Steel
Dureza / Hardness: 61-63 HRC

STOCK

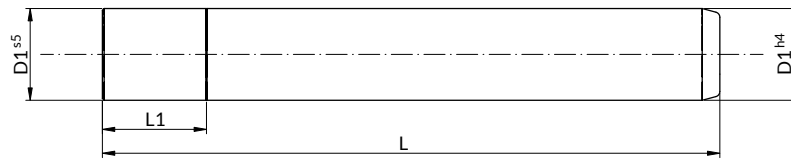

D1	L1	L															
		125	140	150	160	175	190	200	210	225	240	250	260	275	300	325	350
18	27	•	-	•	-	•	-	•	-	-	-	-	-	-	-	-	-
19	27	•	-	•	-	•	-	•	-	-	-	-	-	-	-	-	-
24	44	•	•	•	•	•	•	•	•	•	•	•	-	-	-	-	-
25	44	•	•	•	•	•	•	•	•	•	•	•	-	-	-	-	-
30	49	•	•	•	•	•	•	•	•	•	•	•	-	•	•	•	-
32	49	•	•	•	•	•	•	•	•	•	•	•	-	•	•	•	-
40	54	-	-	•	•	•	•	•	•	•	•	•	•	•	•	•	-
42	54	-	-	•	•	•	•	•	•	•	•	•	•	•	•	•	-
50	59	-	-	-	-	•	-	•	-	•	•	•	•	•	•	•	•
52	59	-	-	-	-	•	-	•	-	•	•	•	•	•	•	•	•

Forma de pedido: CIN + D1*L

How to order: CIN + D1*L

COLUMNA GUÍA CIAF GUIDE PILLAR CIAF

Material: Acero Cementación / Case Hardened Steel
Dureza / Hardness: 61-63 HRC

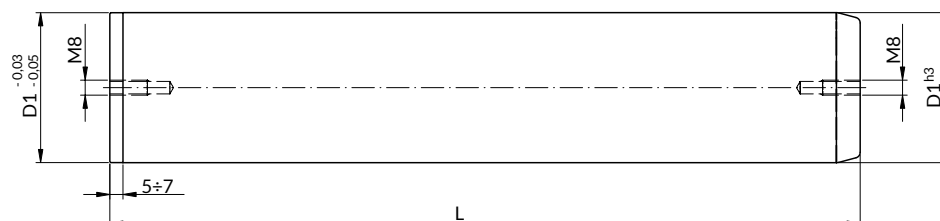

Norma / Standard: DIN 9825 - ISO 9182-2

D1	L																		
	90	100	112	125	140	160	180	200	224	250	280	315	355	400	450	500	600	700	800
15	•	•	•	•	•	•	•	•	•	•	-	-	-	-	-	-	-	-	-
16	•	•	•	•	•	•	•	•	•	•	-	-	-	-	-	-	-	-	-
19	-	•	•	•	•	•	•	•	•	•	-	-	-	-	-	-	-	-	-
20	-	•	•	•	•	•	•	•	•	•	-	-	-	-	-	-	-	-	-
24	-	-	-	•	•	•	•	•	•	•	•	•	•	•	•	•	-	-	-
25	-	-	-	•	•	•	•	•	•	•	•	•	•	•	•	•	-	-	-
30	-	-	-	•	•	•	•	•	•	•	•	•	•	•	•	•	-	-	-
32	-	-	-	•	•	•	•	•	•	•	•	•	•	•	•	•	-	-	-
38	-	-	-	-	-	•	•	•	•	•	•	•	•	•	•	•	-	-	-
40	-	-	-	-	-	•	•	•	•	•	•	•	•	•	•	•	-	-	-
48	-	-	-	-	-	-	-	•	•	•	•	•	•	•	•	•	-	-	-
50	-	-	-	-	-	-	-	•	•	•	•	•	•	•	•	•	-	-	-
60	-	-	-	-	-	-	-	-	•	•	•	•	•	•	•	•	-	-	-
63	-	-	-	-	-	-	-	-	-	•	•	•	•	•	•	•	-	-	-
80	-	-	-	-	-	-	-	-	-	-	•	•	•	•	•	•	•	•	•

Forma de pedido: CIAF + D1*L
How to order: CIAF + D1*L

COLUMNA GUÍA CPC GUIDE PILLAR CPC

Material: Acero Cementación / Case Hardened Steel
Dureza / Hardness: 61-63 HRC

STOCK

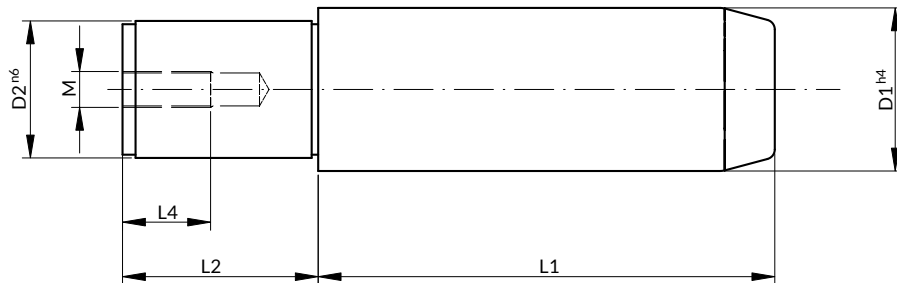

D1	D2	L2	L3	M	L4	L5	L1			
							80	100	125	140
20	16	23	6	M10	22	27	•	-	-	-
25	20	28	8	M10	22	27	-	•	-	-
40	32	50	12	M12	27	42	-	-	•	-
50	40	60	16	M12	27	42	-	-	-	•

Forma de pedido: CPC + D1*L1

How to order: CPC + D1*L1

COLUMNA GUÍA CRN GUIDE PILLAR CRN

Material: Acero Cementación / Case Hardened Steel
Dureza / Hardness: 61-63 HRC

STOCK

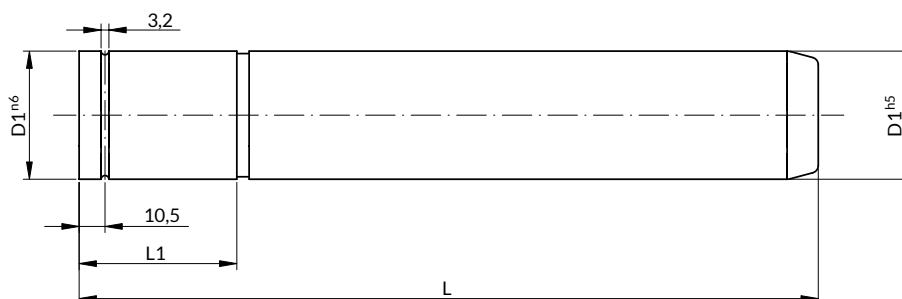

D1	L1	L													
		140	150	160	170	180	190	200	220	240	260	280	300	320	
24	49	•	•	•	•	•	•	•	•	-	-	-	-	-	
25	49	•	•	•	•	•	•	•	•	-	-	-	-	-	
30	54	-	-	•	•	•	•	•	•	•	•	•	-	-	
32	54	-	-	•	•	•	•	•	•	•	•	•	-	-	
40	59	-	-	-	•	•	•	•	•	•	•	•	•	•	
42	59	-	-	-	•	•	•	•	•	•	•	•	-	-	
50	64	-	-	-	-	-	-	•	•	•	•	•	•	-	
52	64	-	-	-	-	-	-	•	•	•	•	•	•	-	

Forma de pedido: CRN + D1*L
How to order: CRN + D1*L

COLUMNA GUÍA CRT GUIDE PILLAR CRT

Material: Acero Cementación / Case Hardened Steel
Dureza / Hardness: 61-63 HRC

STOCK

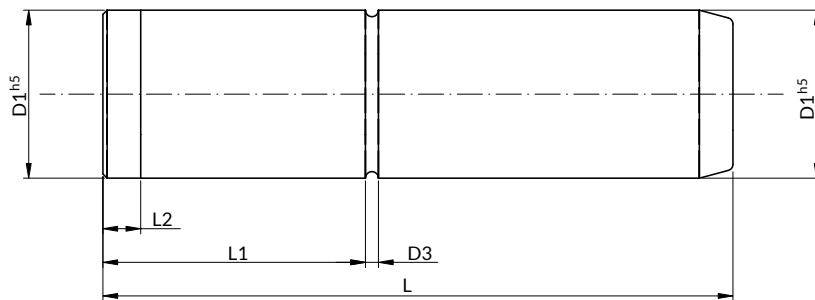

i Recomendación de montaje con brida **BRCO** y anillo **ANR**.
Assembly recommendation with **BRCO** clamp and **ANR** ring.

D1	D3	L1	L2	L															
				100	125	140	160	180	200	220	224	250	280	315	355	400	450	500	
25	2,7	25	8	•	•	•	•	•	•	•	-	-	-	-	-	-	-		
32	4,2	32	12	-	•	•	•	•	•	•	-	•	•	-	-	-	-		
40	4,2	63	12	-	-	-	-	•	•	•	-	•	•	•	-	-	-		
50	4,2	80	12	-	-	-	-	•	•	•	•	•	•	•	•	•	•		
63	6,2	100	18	-	-	-	-	-	-	-	-	•	•	•	•	•	•		
80	6,2	125	18	-	-	-	-	-	-	-	-	-	-	•	•	•	•		
100	6,2	160	18	-	-	-	-	-	-	-	-	-	-	-	•	•	•		

Forma de pedido: CRT + D1*L
How to order: CRT + D1*L

COLUMNA GUÍA CIW GUIDE PILLAR CIW

Material: Acero Cementación / Case Hardened Steel
Dureza / Hardness: 61-63 HRC

STOCK

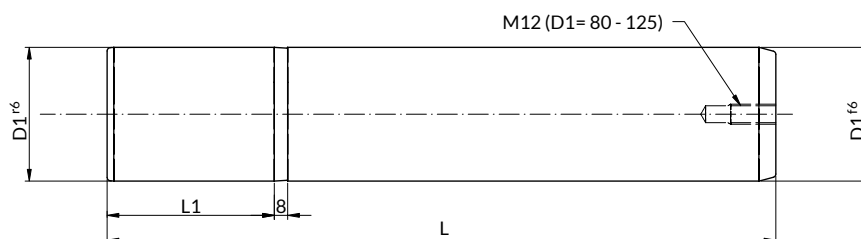

Norma / Standard: DIN 9833

D1	L1	L													
		125	140	160	180	200	224	250	280	315	355	400	450	500	
25	40	•	•	•	•	•	•	-	-	-	-	-	-	-	
32	45	•	•	•	•	•	•	•	-	-	-	-	-	-	
40	56	-	•	•	•	•	•	•	•	-	-	-	-	-	
50	70	-	-	•	•	•	•	•	•	•	•	-	-	-	
63	80	-	-	-	•	•	•	•	•	•	•	•	-	-	
80	100	-	-	-	-	•	•	•	•	•	•	•	•	•	
100	125	-	-	-	-	-	•	-	•	•	•	•	•	•	
125	140	-	-	-	-	-	-	-	-	•	•	•	•	•	

Forma de pedido: CIW + D1*L
How to order: CIW + D1*L

COLUMNA GUÍA CIWH GUIDE PILLAR CIWH

Material: Acero Cementación / Case Hardened Steel
Dureza / Hardness: 61-63 HRC

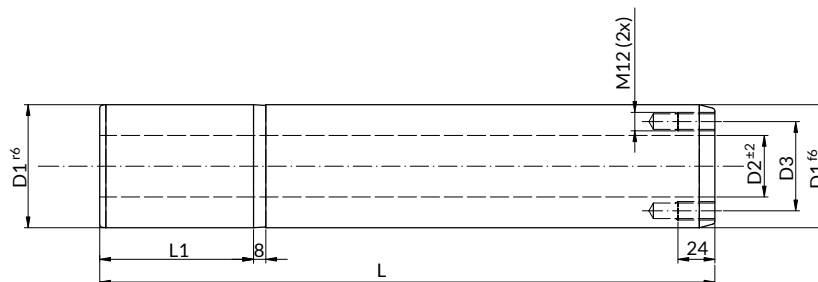

Norma / Standard: DIN 9833

D1	D2	D3	L1	L									
				200	224	250	280	315	355	400	450	500	560
80	40	58	100	•	•	•	•	•	•	•	•	•	-
100	50	72	125	-	•	•	•	•	•	•	•	•	-
125	65	90	140	-	-	-	-	•	•	•	•	•	-
160	95	132	180	-	-	-	-	-	-	•	•	•	•

Forma de pedido: CIWH + D1*L
How to order: CIWH + D1*L

COLUMNA GUÍA CFW GUIDE PILLAR CFW

Material: Acero Cementación / Case Hardened Steel
Dureza / Hardness: 61-63 HRC

STOCK

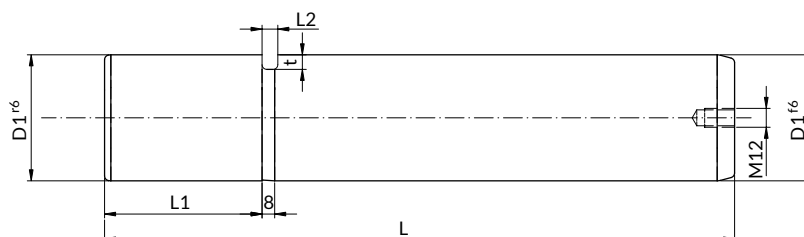

i Recomendación de montaje con brida **BRC**
Assembly recommendation with **BRC** clamp

Norma / Standard: DIN 9833

D1	L1	L2	t	L												
				125	140	160	180	200	224	250	280	315	355	400	450	500
25	40	7	3	•	•	•	•	•	•	-	-	-	-	-	-	-
32	45	7	3	•	•	•	•	•	•	•	-	-	-	-	-	-
40	56	10	4	-	•	•	•	•	•	•	•	-	-	-	-	-
50	70	10	5	-	-	•	•	•	•	•	•	•	•	-	-	-
63	80	12	6,5	-	-	-	•	•	•	•	•	•	•	•	-	-
80	100	12	8	-	-	-	-	-	•	•	•	•	•	•	•	•

Forma de pedido: CFW + D1*L
How to order: CFW + D1*L

COLUMNA GUÍA CFWH GUIDE PILLAR CFWH

Material: Acero Cementación / Case Hardened Steel
Dureza / Hardness: 61-63 HRC

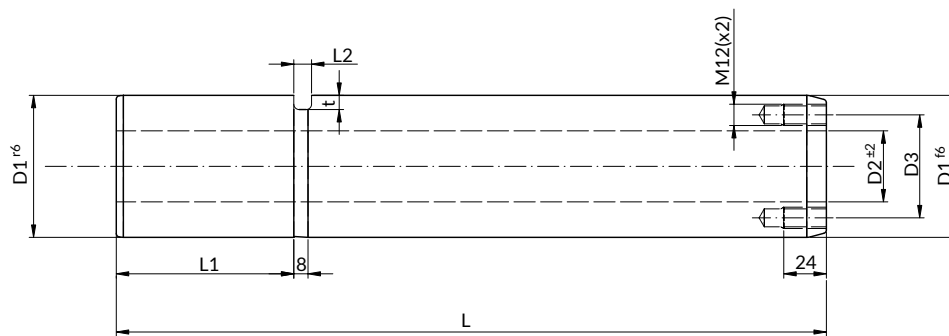

i Recomendación de montaje con brida [BRC](#)
Assembly recommendation with [BRC](#) clamp

Norma / Standard: DIN 9833

D1	D2	D3	L1	L2	t	L								
						224	250	280	315	355	400	450	500	560
80	40	58	100	12	8	•	•	•	•	•	•	-	-	-
100	50	72	125	12	10	-	-	•	•	•	•	-	-	-
125	65	90	140	12	12	-	-	-	•	•	•	•	•	-
160	95	132	180	18	15	-	-	-	-	-	•	•	•	•

Forma de pedido: CFWH + D1*L

How to order: CFWH + D1*L

COLUMNA GUÍA CON VALONA CE GUIDE PILLAR WITH COLLAR CE

Material: Acero Cementación / Case Hardened Steel
Dureza / Hardness: 61-63 HRC

STOCK

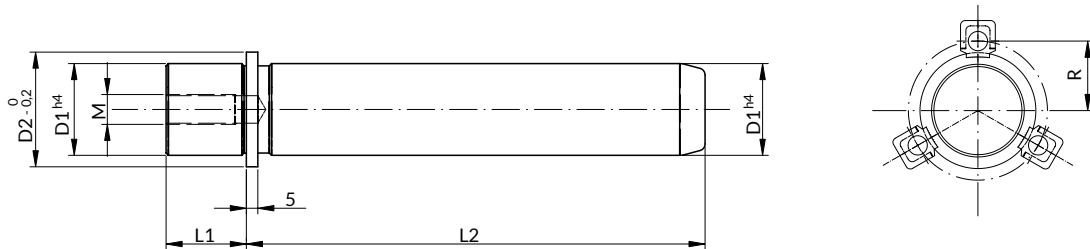

i Recomendación de montaje con arandela **RTE** o brida **BRE**
Assembly recommendation with **RTE** washer or clamp **BRE**

D1 ≤ 25 : 3 x **BRE 6** + **TCI M6x15**

D1 > 25 : 3 x **BRE 8** / **BREA 8** + **TCI M8x20**

D1	D2	L1	R	M	L2																							
					100	110	120	130	140	150	160	170	180	200	220	240	260	280	300	320	360	400						
18	25	20	16,5	M8	•	•	•	•	•	•	•	-	-	-	-	-	-	-	-	-	-	-	-	-	-	-	-	-
19	25	20	16,5	M8	•	•	•	•	•	•	•	-	-	-	-	-	-	-	-	-	-	-	-	-	-	-	-	-
24	32	25	20	M10	•	•	•	•	•	•	•	•	•	•	•	-	-	-	-	-	-	-	-	-	-	-	-	-
25	32	25	20	M10	•	•	•	•	•	•	•	•	•	•	•	-	-	-	-	-	-	-	-	-	-	-	-	-
30	40	30	25	M10	•	•	•	•	•	•	•	•	•	•	•	•	•	•	•	•	-	-	-	-	-	-	-	-
32	40	30	25	M10	•	•	•	•	•	•	•	•	•	•	•	•	•	•	•	•	-	-	-	-	-	-	-	-
40	50	35	30	M12	•	•	•	•	•	•	•	•	•	•	•	•	•	•	•	•	•	•	-	-	-	-	-	-
42	50	35	30	M12	•	•	•	•	•	•	•	•	•	•	•	•	•	•	•	•	•	•	-	-	-	-	-	-
50	62	45	36	M12	-	•	•	•	•	•	•	•	•	•	•	•	•	•	•	•	•	•	•	•	•	•	•	•
52	62	45	36	M12	-	•	•	•	•	•	•	•	•	•	•	•	•	•	•	•	•	•	•	•	•	•	•	•
63	73	49	41,5	M12	-	-	-	•	•	•	•	•	•	•	•	•	•	•	•	•	•	•	•	•	•	•	•	•
80*	93	59	51,5	M12	-	-	-	-	-	-	-	-	-	-	•	•	•	•	•	•	•	•	•	•	•	•	•	•

*Con rosca M10 en la punta / With M10 thread on tip

Forma de pedido CE + D1*L2

How to order: CE + D1*L2

COLUMNA GUÍA CON VALONA CEN GUIDE PILLAR WITH COLLAR CEN

Material: Acero Cementación / Case Hardened Steel
Dureza / Hardness: 61-63 HRC

STOCK

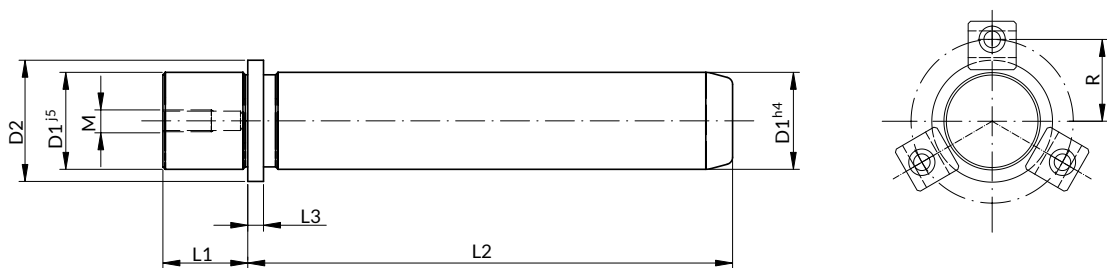

i Recomendación de montaje / Assembly recommendation
D1 ≤ 25 : 3x BRM 25 + TCC M5X16
D1 > 25 : 3x BRW 20 + TCC M6X16

D1	D2	L1	L3	R	M	L2													
						100	110	125	140	160	180	200	220	240	260	280	315	355	400
24	33	24	5	23	M6	•	•	•	•	•	•	•	•	•	-	-	-	-	-
25	33	24	5	23	M6	•	•	•	•	•	•	•	•	•	-	-	-	-	-
30	41	30	6,5	28,5	M8	•	•	•	•	•	•	•	•	•	•	•	•	-	-
32	41	30	6,5	29,5	M8	•	•	•	•	•	•	•	•	•	•	•	•	-	-
40	51	37	6,5	33,5	M8	-	•	•	•	•	•	•	•	•	•	•	•	-	-
42	51	37	6,5	34,5	M8	-	•	•	•	•	•	•	•	•	•	•	•	-	-
50	64	45	6,5	40	M10	-	-	-	•	•	•	•	•	•	•	•	•	•	•
52	64	45	6,5	40	M10	-	-	-	•	•	•	•	•	•	•	•	•	•	•
63	76	49	6,5	46	M12	-	-	-	-	-	-	•	•	•	•	•	•	•	•
80	93	60	6,5	55	M12	-	-	-	-	-	-	•	•	•	•	•	•	•	•

Forma de pedido: CEN + D1*L2
How to order: CEN + D1*L2

COLUMNA GUÍA CON VALONA CEI GUIDE PILLAR WITH COLLAR CEI

Material: Acero Cementación / Case Hardened Steel
Dureza / Hardness: 61-63 HRC

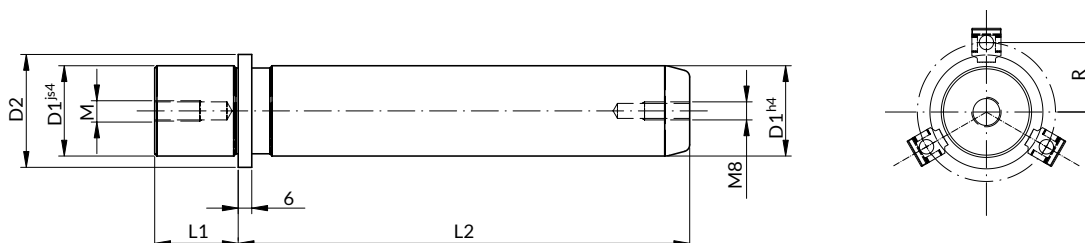

i Recomendación de montaje con arandela RTI o brida BREI 6
Assembly recommendation with RTI washer or clamp BREI 6

D1 < 38: 3 x BREI 6 + TCI M6x15
D1 ≥ 38: 4 x BREI 6 + TCI M6x15

D1	D2	L1	R	M	L2												
					100	112	125	140	160	180	200	224	250	280	315	355	400
15	22	20	16,5	M8	•	•	•	•	•	•	•	-	-	-	-	-	-
16	22	20	16,5	M8	•	•	•	•	•	•	•	-	-	-	-	-	-
19	25	23	18	M8	•	•	•	•	•	•	•	-	-	-	-	-	-
20	25	23	18	M8	•	•	•	•	•	•	•	-	-	-	-	-	-
24	32	30	21,5	M8	•	•	•	•	•	•	•	•	•	-	-	-	-
25	32	30	21,5	M8	•	•	•	•	•	•	•	•	•	-	-	-	-
30	40	37	25,5	M8	-	•	•	•	•	•	•	•	•	•	•	-	-
32	40	37	25,5	M8	-	•	•	•	•	•	•	•	•	•	•	-	-
38	50	37	30,5	M8	-	-	•	•	•	•	•	•	•	•	•	•	-
40	50	37	30,5	M8	-	-	•	•	•	•	•	•	•	•	•	•	-
48	63	47	37	M8	-	-	-	•	•	•	•	•	•	•	•	•	•
50	63	47	37	M8	-	-	-	•	•	•	•	•	•	•	•	•	•
60	80	47	45,5	M8	-	-	-	-	•	•	•	•	•	•	•	•	•
63	80	47	45,5	M8	-	-	-	-	•	•	•	•	•	•	•	•	•
80	95	60	53	M12	-	-	-	-	-	-	•	•	•	•	•	•	•

Forma de pedido CEI + D1*L2
How to order CEI + D1*L2

COLUMNA GUÍA CON VALONA CEJ GUIDE PILLAR WITH COLLAR CEJ

Material: Acero Cementación / Case Hardened Steel
Dureza / Hardness: 61-63 HRC

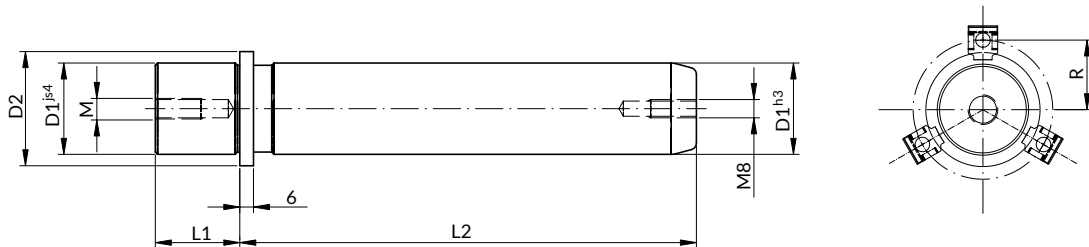

i Recomendación de montaje con arandela RTI o brida BREI 6
Assembly recommendation with RTI washer or clamp BREI 6

D1 < 38 : 3 x BREI 6 + TCI M6x15
D1 ≥ 38 : 4 x BREI 6 + TCI M6x15

Norma / Standard: DIN 9825-4 - ISO 9182-5

D1	D2	L1	R	M	L2											
					100	112	125	140	160	180	200	224	250	280	315	355
15	22	20	16,5	M8	•	•	•	•	•	•	•	-	-	-	-	-
16	22	20	16,5	M8	•	•	•	•	•	•	•	-	-	-	-	-
19	25	23	18	M8	•	•	•	•	•	•	•	-	-	-	-	-
20	25	23	18	M8	•	•	•	•	•	•	•	-	-	-	-	-
24	32	30	21,5	M8	•	•	•	•	•	•	•	•	•	-	-	-
25	32	30	21,5	M8	•	•	•	•	•	•	•	•	•	-	-	-
30	40	37	25,5	M8	-	•	•	•	•	•	•	•	•	•	•	-
32	40	37	25,5	M8	-	•	•	•	•	•	•	•	•	•	•	-
38	50	37	30,5	M8	-	-	•	•	•	•	•	•	•	•	•	-
40	50	37	30,5	M8	-	-	•	•	•	•	•	•	•	•	•	-
48	63	47	37	M8	-	-	-	•	•	•	•	•	•	•	•	•
50	63	47	37	M8	-	-	-	•	•	•	•	•	•	•	•	•
60	80	47	45,5	M8	-	-	-	-	•	•	•	•	•	•	•	•
63	80	47	45,5	M8	-	-	-	-	•	•	•	•	•	•	•	•
80	95	60	53	M12	-	-	-	-	-	-	•	•	•	•	•	•

Forma de pedido: CEJ + D1*L2
How to order: CEJ + D1*L2

COLUMNA GUÍA CÓNICA COCI CONICAL GUIDE PILLAR COCI

Material: Acero Cementación / Case Hardened Steel
Dureza / Hardness: 61-63 HRC



i Se suministra con arandela y tornillo
Washer and screw are included



Norma / Standard: DIN 9825-4 - ISO 9182-5

D1	D2	L2	L3	M	L1											
					100	112	125	140	160	180	200	224	250	280	315	355
24	25	35	3	8	L=123	L=135	L=148	L=163	L=183	L=203	L=223	L=247	L=273	-	-	-
25	25	35	3	8	L=123	L=135	L=148	L=163	L=183	L=203	L=223	L=247	L=273	-	-	-
30	32	48	3	8	-	L=145	L=158	L=173	L=193	L=213	L=233	L=257	L=283	L=313	-	-
32	32	48	3	8	-	L=145	L=158	L=173	L=193	L=213	L=233	L=257	L=283	L=313	-	-
38	40	48	5	8	-	-	L=158	L=173	L=193	L=213	L=233	L=257	L=283	L=313	L=348	-
40	40	48	5	8	-	-	L=158	L=173	L=193	L=213	L=233	L=257	L=283	L=313	L=348	-
48	50	58	5	10	-	-	-	L=180	L=200	L=220	L=240	L=264	L=290	L=320	L=355	L=395
50	50	58	5	10	-	-	-	L=180	L=200	L=220	L=240	L=264	L=290	L=320	L=355	L=395
60	63	69	6	12	-	-	-	-	L=211	L=231	L=251	L=275	L=301	L=331	L=366	L=406
63	63	69	6	12	-	-	-	-	L=211	L=231	L=251	L=275	L=301	L=331	L=366	L=406

Forma de pedido: COCI + D1*L2
How to order: COCI + D1*L2

CASQUILLO CÓNICO CACI CONICAL BUSH CACI

Material: Acero Cementación / Case Hardened Steel
Dureza / Hardness: 61-63 HRC

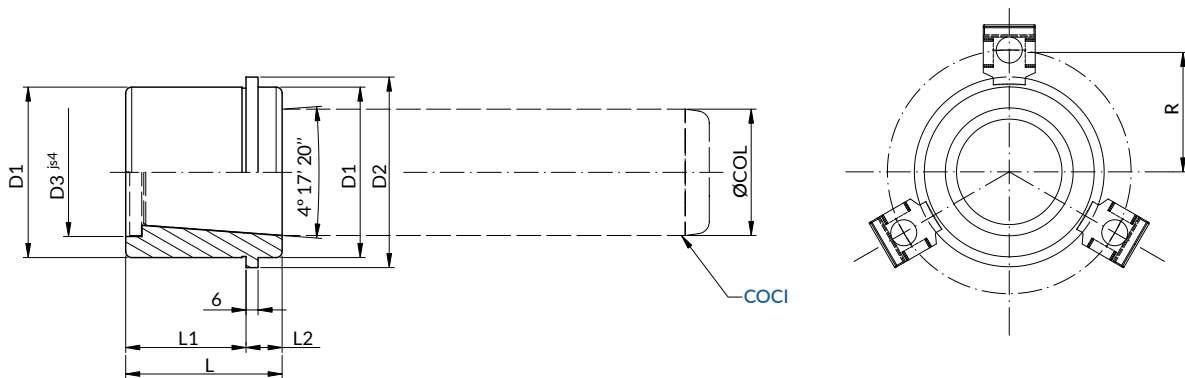

i Recomendación de montaje / Assembly recommendation
 $\varnothing \text{COL} \leq 48$: 3 x BREI 6 + TCI M6x15
 $\varnothing \text{COL} > 48$: 4 x BREI 6 + TCI M6x15

Norma / Standard: DIN 9825-4 - ISO 9182-5

$\varnothing \text{COL}$	D1	D2	D3	L	L1	L2	R
24	40	48	26	49	37	12	30
24	40	48	26	59	47	12	30
25	40	48	26	49	37	12	30
25	40	48	26	59	47	12	30
30	48	56	33	52	37	15	33,5
30	48	56	33	62	47	15	33,5
32	48	56	33	52	37	15	33,5
32	48	56	33	62	47	15	33,5
38	58	66	41	62	47	15	38,5
38	58	66	41	75	60	15	38,5
40	58	66	41	62	47	15	38,5
40	58	66	41	75	60	15	38,5
48	70	80	51	65	47	18	45,5
48	70	80	51	78	60	18	45,5
50	70	80	51	65	47	18	45,5
50	70	80	51	78	60	18	45,5
60	85	95	64	78	60	18	53
60	85	95	64	95	77	18	53
63	85	95	64	78	60	18	53
63	85	95	64	95	77	18	53

Forma de pedido: CACI + D1*L

How to order: CACI + D1*L

COLUMNA GUÍA CON VALONA CEV GUIDE PILLAR WITH COLLAR CEV

Material: Acero Cementación / Case Hardened Steel
Dureza / Hardness: 61-63 HRC

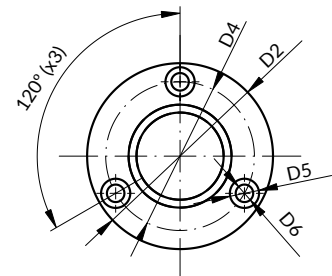
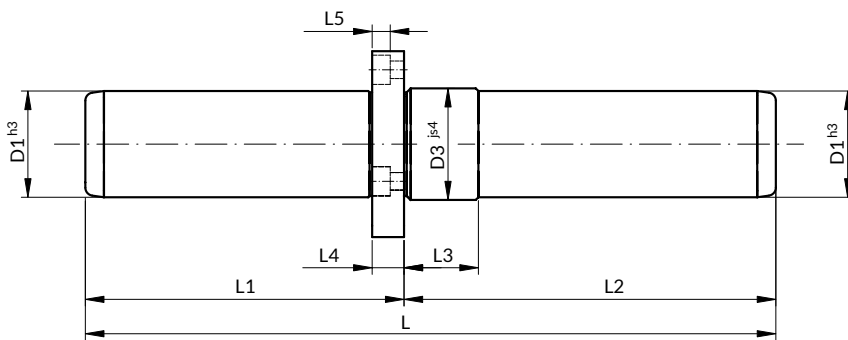

															L																
D1	D2	D3	D4	D5	D6	L3	L4	L5	160		170		180		190		200		210		220		230		240		250		260		
									L1	L2	L1	L2	L1	L2	L1	L2	L1	L2	L1	L2	L1	L2	L1	L2	L1	L2	L1	L2	L1	L2	L1
19	42	22	32	8	4,5	20	8	4,6	80	100	80	110	90	110	100	110	-	-	100	110	-	-	-	-	-	-	-	-	-	-	-
25	48	26	38	8	4,5	22	8	4,6	80	100	80	110	90	110	90	120	100	120	90	120	100	120	110	120	-	-	-	-	-	-	
32	60	34	48	10	5,5	25	10	5,7	80	100	80	110	90	110	90	120	100	120	90	120	100	120	100	130	110	130	110	140	-	-	
40	70	42	56	11	6,6	27	12	6,8	-	-	-	-	90	110	90	120	100	120	90	120	100	120	100	130	110	130	110	140	120	140	

Forma de pedido: CEV + D1*L
How to order: CEV + D1*L

COLUMNA DOBLE DIÁMETRO CDD GUIDE PILLAR DOUBLE DIAMETER CDD

Material: Acero Cementación / Case Hardened Steel
Dureza / Hardness: 61-63 HRC

STOCK

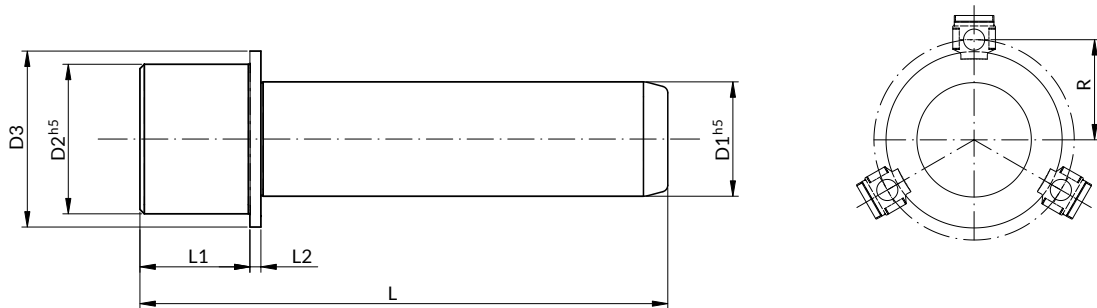

i Recomendación de montaje / Assembly recommendation
D1≤63 = 3x BRE 6 + TCI M6x15
D1=80 = 3x BRE 8 / BRE A 8 + TCI M8x20

D1	D2	D3	L1	L2	R	L															
						130	140	160	170	180	190	200	212	225	235	240	250	275	300	325	355
15	28	34	25	5	20,5	•	•	-	-	-	-	-	-	-	-	-	-	-	-	-	-
16	28	34	25	5	20,5	•	•	-	-	-	-	-	-	-	-	-	-	-	-	-	-
18	32	40	30	5	23,5	•	•	•	-	-	-	-	-	-	-	-	-	-	-	-	-
19	32	40	30	5	23,5	•	•	•	-	-	-	-	-	-	-	-	-	-	-	-	-
24	40	45	35	5	27,5	-	•	•	•	•	-	-	-	-	-	-	-	-	-	-	-
25	40	45	35	5	27,5	-	•	•	•	•	-	-	-	-	-	-	-	-	-	-	-
30	48	55	40	5	32,5	-	-	•	•	•	•	-	-	-	-	-	-	-	-	-	-
32	48	55	40	5	32,5	-	-	•	•	•	•	-	-	-	-	-	-	-	-	-	-
40	58	70	45	5	40	-	-	-	-	•	•	•	•	•	-	•	-	-	-	-	-
42	58	70	45	5	40	-	-	-	-	•	•	•	•	•	-	•	-	-	-	-	-
50	68	80	50	5	45	-	-	-	-	-	•	•	•	-	•	-	-	-	-	-	-
52	68	80	50	5	45	-	-	-	-	-	•	•	•	-	•	-	-	-	-	-	-
60	85	95	55	5	52,5	-	-	-	-	-	-	-	-	-	•	-	•	•	•	-	-
63	85	95	55	5	52,5	-	-	-	-	-	-	-	-	-	•	-	•	•	•	-	-
80	100	120	60	6,5	65	-	-	-	-	-	-	-	-	-	•	-	•	•	•	•	•

Forma de pedido: CDD + D1*L
How to order: CDD + D1*L

COLUMNA GUÍA CDDN GUIDE PILLAR CDDN

Material: Acero de cementación / Hardened steel
Dureza / Hardness: 62 ± 2 HRC

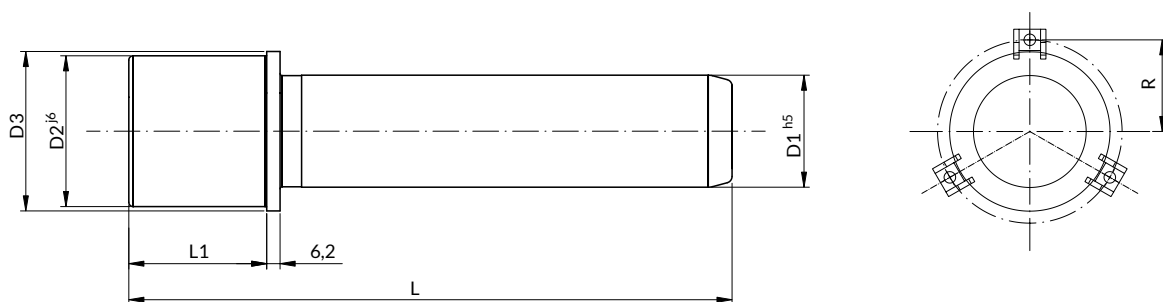

i Recomendación de montaje con brida BRE 5 (x3)
Assembly recommendation with BRE 5 (x3)

D1	D2	D3	L1	R	L							
					140	160	180	200	220	240	260	280
24	40	44	49	27,5	•	•	•	•	•	-	-	-
25	40	44	49	27,5	•	•	•	•	•	-	-	-
30	48	52	54	31,5	-	•	•	•	•	•	-	-
32	48	52	54	31,5	-	•	•	•	•	•	-	-
40	58	62	59	36,5	-	-	•	•	•	•	•	•
42	58	62	59	36,5	-	-	•	•	•	•	•	•
50	70	74	64	42,5	-	-	-	•	•	•	•	•
52	70	74	64	42,5	-	-	-	•	•	•	•	•

Forma de pedido: CDDN + D1*L
How to order: CDDN + D1*L

CASQUILLO GUÍA CAC - CBC

GUIDE BUSH CAC - CBC

CAC



Material: Acero Cementación / Case Hardened Steel
Dureza / Hardness: 61-63 HRC

STOCK

CBC



Material: Bronce al aluminio / Aluminium bronze
Dureza / Hardness: HB > 190

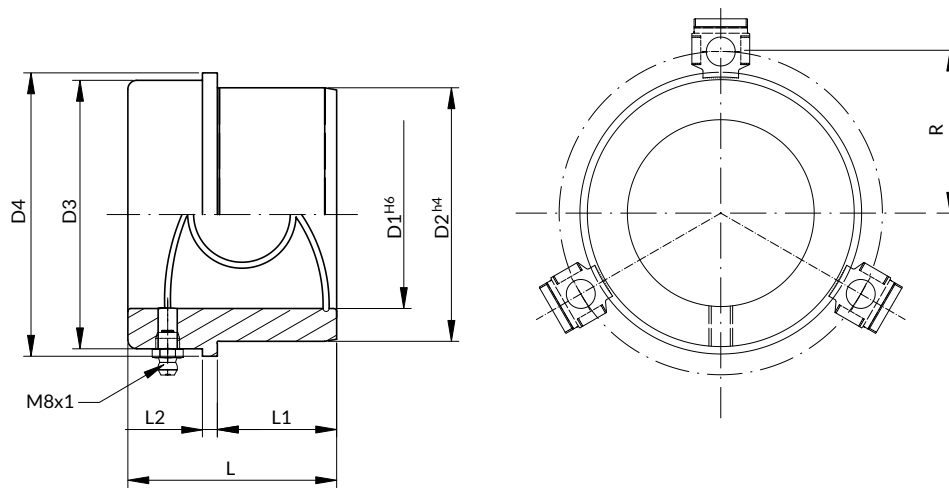

i Recomendación de montaje / Assembly recommendation
D1 ≤ 63 = 3 x BRE 6 + TCI M6x15
D1 = 80 = 3 x BRE 8 / BRE A 8 + TCI M8x20

D1	D2	D3	D4	L1	L2	R	L							
							31	33	40	45	48	57	70	100
15	28	30	34	15	5	21,5	•	-	-	-	-	-	-	-
16	28	30	34	15	5	21,5	•	-	-	-	-	-	-	-
18	32	34	38	17	5	23,5	-	•	-	-	-	-	-	-
19	32	34	38	17	5	23,5	-	•	-	-	-	-	-	-
24	40	43	48	22	5	29	-	-	•	-	-	-	-	-
25	40	43	48	22	5	29	-	-	•	-	-	-	-	-
30	48	53	58	27	5	34	-	-	-	•	-	-	-	-
32	48	53	58	27	5	34	-	-	-	•	-	-	-	-
40	58	66	72	30	5	41	-	-	-	-	•	-	-	-
42	58	66	72	30	5	41	-	-	-	-	•	-	-	-
50	68	77	82	35	5	46	-	-	-	-	-	•	-	-
52	68	77	82	35	5	46	-	-	-	-	-	•	-	-
60	85	90	95	40	5	52,5	-	-	-	-	-	-	•	-
63	85	90	95	40	5	52,5	-	-	-	-	-	-	•	-
80	100	112	120	55	6,5	65	-	-	-	-	-	-	-	•

Forma de pedido / How to order: CAC + D1*L
CBC + D1*L

CASQUILLO GUÍA CAV - CBV

GUIDE BUSH CAV - CBV

CAV



CBV



Material: Acero Cementación / Case Hardened Steel
Dureza / Hardness: 61-63 HRC

Material: Bronce al aluminio / Aluminium bronze
Dureza / Hardness: HB> 190

STOCK

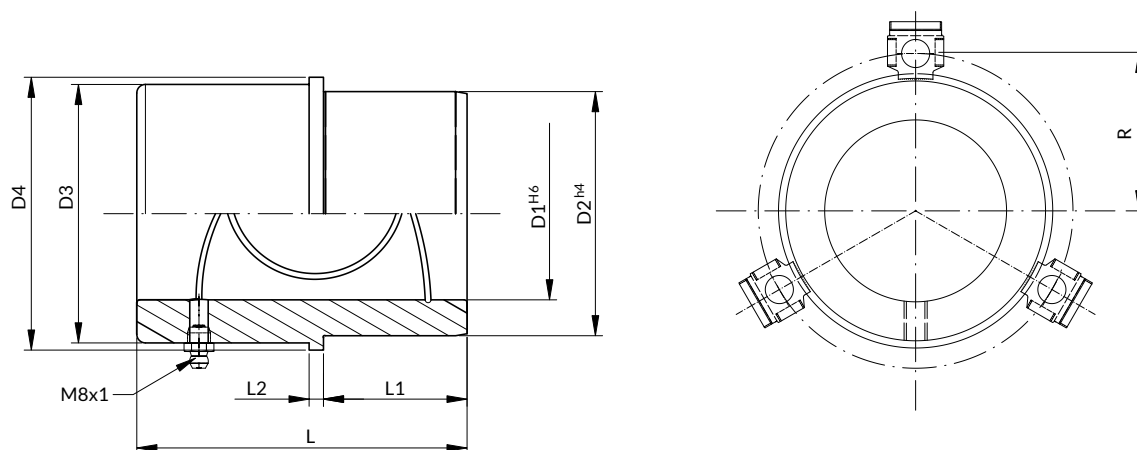

i Recomendación de montaje / Assembly recommendation
D1≤63 = 3 x BRE 6 + TCI M6x15
D1=80 = 3 x BRE 8 / BRE A 8 + TCI M8x20

D1	D2	D3	D4	L1	L2	R	L								
							50	60	65	75	80	85	100	115	125
15	28	30	34	20	5	21,5	•	-	-	-	-	-	-	-	-
16	28	30	34	20	5	21,5	•	-	-	-	-	-	-	-	-
18	32	34	38	25	5	23,5	-	•	-	-	-	-	-	-	-
19	32	34	38	25	5	23,5	-	•	-	-	-	-	-	-	-
24	40	43	48	30	5	29	-	•	-	•	-	-	-	-	-
25	40	43	48	30	5	29	-	•	-	•	-	-	-	-	-
30	48	53	58	30	5	34	-	•	-	-	•	-	-	-	-
32	48	53	58	30	5	34	-	•	-	-	•	-	-	-	-
40	58	66	72	35	5	41	-	-	•	-	-	•	-	-	-
42	58	66	72	35	5	41	-	-	•	-	-	•	-	-	-
50	68	77	82	45	5	46	-	-	-	•	-	-	•	-	-
52	68	77	82	45	5	46	-	-	-	•	-	-	•	-	-
60	85	90	95	50	5	52,5	-	-	-	-	-	-	-	•	-
63	85	90	95	50	5	52,5	-	-	-	-	-	-	-	•	-
80	100	112	120	55	6,5	65	-	-	-	-	-	-	-	-	•

Forma de pedido / How to order: CAV + D1*L
CBV + D1*L

CASQUILLO GUÍA CAL - CBL

GUIDE BUSH CAL - CBL

CAL



Material: Acero Cementación / Case Hardened Steel
Dureza / Hardness: 61-63 HRC

STOCK

CBL



Material: Bronce al aluminio / Aluminium bronze
Dureza / Hardness: HB > 190

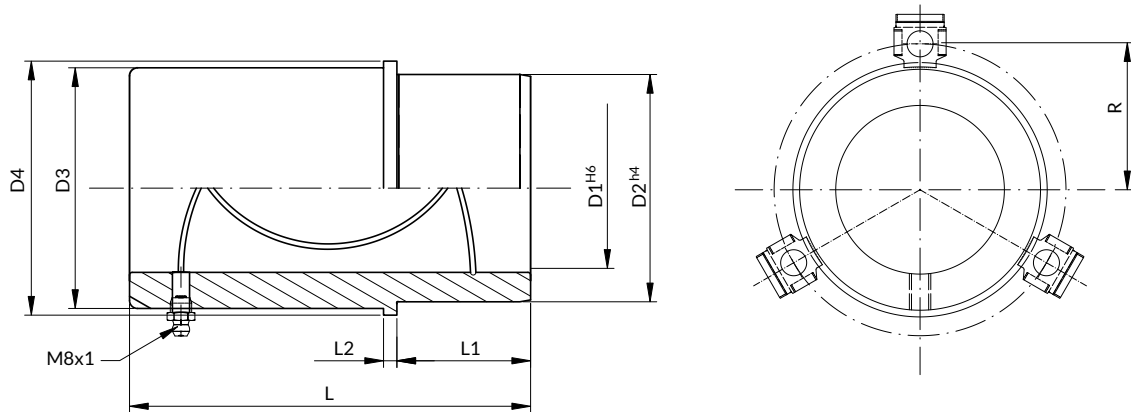

i Recomendación de montaje / Assembly recommendation
D1 ≤ 63 = 3 x BRE 6 + TCI M6x15
D1 = 80 = 3 x BRE 8 / BREA 8 + TCI M8x20

D1	D2	D3	D4	L1	L2	R	L								
							105	110	115	125	130	135	145	150	180
18	32	34	38	25	5	23,5	•	-	-	•	-	-	-	-	-
19	32	34	38	25	5	23,5	•	-	-	•	-	-	-	-	-
24	40	43	48	30	5	29	-	•	-	-	•	-	-	-	-
25	40	43	48	30	5	29	-	•	-	-	•	-	-	-	-
30	48	53	58	30	5	34	-	•	-	-	•	-	-	-	-
32	48	53	58	30	5	34	-	•	-	-	•	-	-	-	-
40	58	66	72	35	5	41	-	-	•	-	-	•	-	-	-
42	58	66	72	35	5	41	-	-	•	-	-	•	-	-	-
50	68	77	82	45	5	46	-	-	-	•	-	-	•	-	-
52	68	77	82	45	5	46	-	-	-	•	-	-	•	-	-
60	85	90	95	50	5	52,5	-	-	-	-	•	-	-	•	-
63	85	90	95	50	5	52,5	-	-	-	-	•	-	-	•	-
80	100	112	120	55	6,5	65	-	-	-	-	-	-	-	-	•

Forma de pedido / How to order: CAL + D1*L
CBL + D1*L

CASQUILLO GUÍA CAA GUIDE BUSH CAA

Material: Acero Cementación / Case Hardened Steel
Dureza / Hardness: 61-63 HRC

STOCK

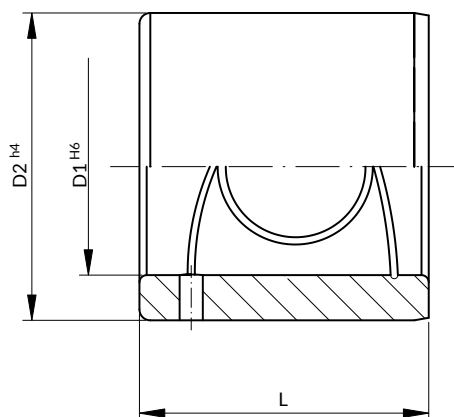

D1	D2	L										
		35	55	60	65	70	75	80	85	95	115	
15	28	•	-	•	-	-	-	-	-	-	-	-
16	28	•	-	•	-	-	-	-	-	-	-	-
18	32	-	•	-	•	-	-	-	-	-	-	-
19	32	-	•	-	•	-	-	-	-	-	-	-
24	40	-	•	-	-	•	-	-	-	-	-	-
25	40	-	•	-	-	•	-	-	-	-	-	-
30	48	-	-	•	-	-	•	-	-	-	-	-
32	48	-	-	•	-	-	•	-	-	-	-	-
40	58	-	-	-	-	•	-	-	•	-	-	-
42	58	-	-	-	-	•	-	-	•	-	-	-
50	68	-	-	-	-	-	-	•	-	•	-	-
52	68	-	-	-	-	-	-	•	-	•	-	-
60	85	-	-	-	-	-	-	•	-	•	-	-
63	85	-	-	-	-	-	-	•	-	•	-	-
80	100	-	-	-	-	-	-	-	-	•	•	-

Forma de pedido: CAA + D1*L
How to order: CAA + D1*L

CASQUILLO GUÍA CACN - CBCN

GUIDE BUSH CACN - CBCN

CACN



Material: Acero de cementación / Hardened steel
Dureza / Hardness: 62 ± 2 HRC

CBCN



Material: Bronce al aluminio / Aluminium bronze
Dureza / Hardness: HB > 190

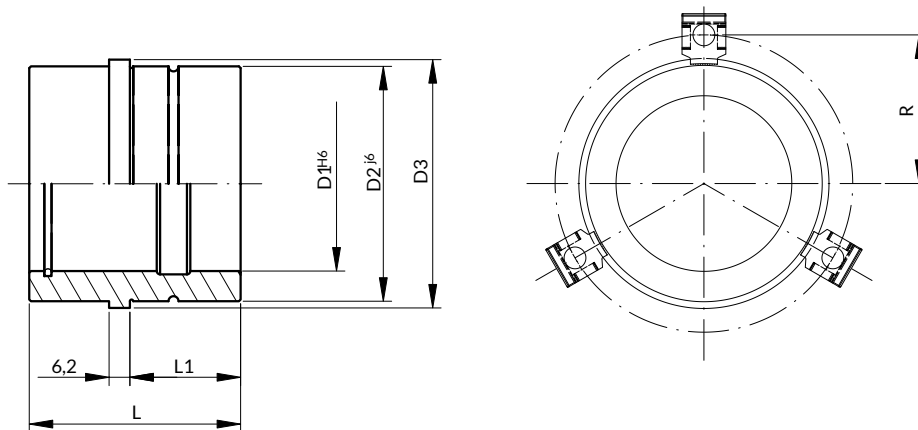

i Recomendación de montaje con brida BREI 6 (x3)
Assembly recommendation with BREI 6 clamp (x3)

D1	D2	D3	L1	R	L		
					47	52	63
24	40	44	25	29	•	-	-
25	40	44	25	29	•	-	-
30	48	52	30	33	-	•	-
32	48	52	30	33	-	•	-
40	58	62	33	38	-	-	•
42	58	62	33	38	-	-	•
50	70	74	33	44	-	-	•
52	70	74	33	44	-	-	•

Forma de pedido / How to order: CACN + D1*L
CBCN + D1*L

CASQUILLO GUÍA CAVN - CBVN

GUIDE BUSH CAVN - CBVN

CAVN



Material: Acero de cementación / Hardened steel
Dureza / Hardness: 62 ± 2 HRC

CBVN



Material: Bronce al aluminio / Aluminium bronze
Dureza / Hardness: HB > 190

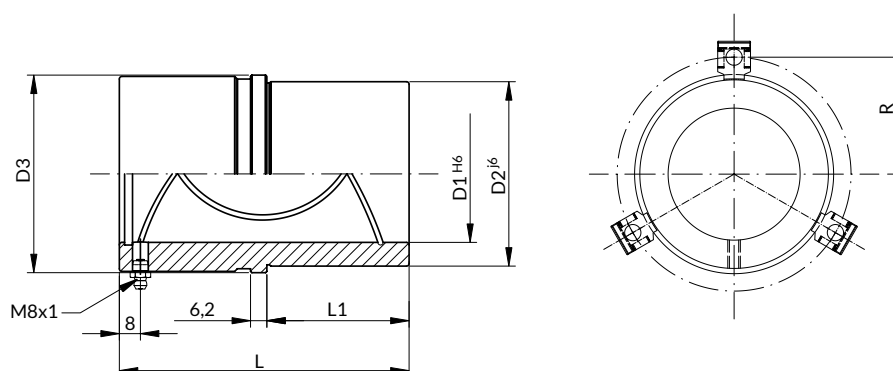

i Recomendación de montaje con brida BREI 6 (x3)
Assembly recommendation with BREI 6 clamp (x3)

D1	D2	D3	L1	R	L									
					64	76	80	81	90	100	110	120	130	145
24	40	44	34	29	•	-	•	-	-	-	•	-	-	-
25	40	44	34	29	•	-	•	-	-	-	•	-	-	-
30	48	52	39	33	•	-	-	-	•	-	-	•	-	-
32	48	52	39	33	•	-	-	-	•	-	-	•	-	-
40	58	62	49	38	-	•	-	-	-	•	-	-	•	-
42	58	62	49	38	-	•	-	-	-	•	-	-	•	-
50	70	74	54	44	-	-	-	•	-	-	•	-	-	•
52	70	74	54	44	-	-	-	•	-	-	•	-	-	•

Forma de pedido / How to order: CAVN + D1*L
CBVN + D1*L

CASQUILLO GUÍA CAEC - CBEC - CABEC

GUIDE BUSH CAEC - CBEC - CABEC

CAEC



Material: Acero Cementación
Case Hardened Steel
Dureza / Hardness: 61-63 HRC

CBEC



Material: Bronce al aluminio
Aluminium bronze
Dureza / Hardness: HB > 190

CABEC



Material: Acero Cementación + Bronce
Case Hardened Steel + Bronze
Dureza acero / Steel hardness: 52-54 HRC

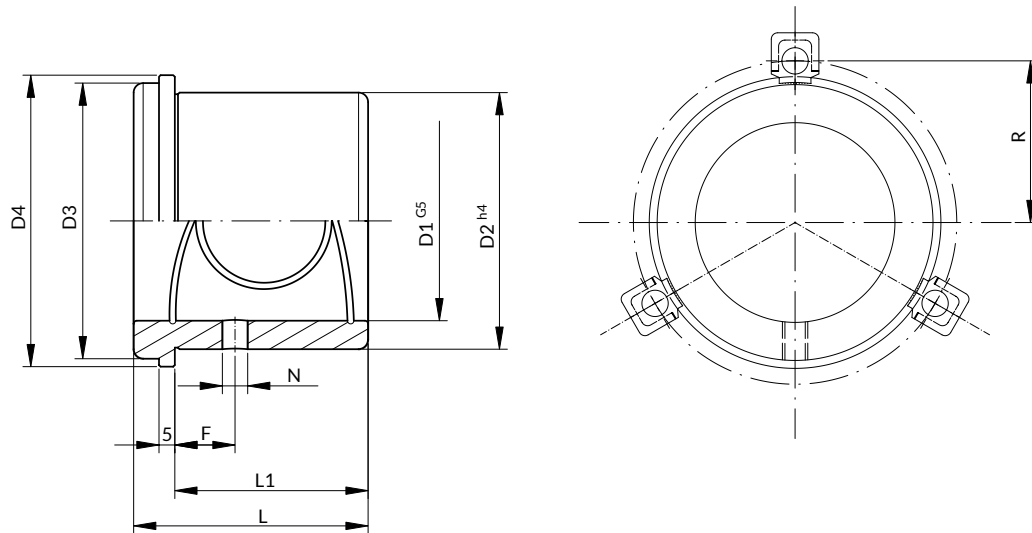

i Recomendación de montaje / Assembly recommendation
D1 ≤ 25 : 3x BRE 6 + TCI M6x15
D1 > 25 : 3x BRE 8 / BRE A 8 + TCI M8x20

D1	D2	D3	D4	L1	N	F	R	L						
								31	36	43	51	61	74	91
18	28	29	34	18	5	8	21	•	-	-	-	-	-	-
19	28	29	34	18	5	8	21	•	-	-	-	-	-	-
24	38	39	44	23	5	12	26	-	•	-	-	-	-	-
25	38	39	44	23	5	12	26	-	•	-	-	-	-	-
30	45	48	53	30	5	16	31,5	-	-	•	-	-	-	-
32	45	48	53	30	5	16	31,5	-	-	•	-	-	-	-
40	54	58	63	38	8	19	36,5	-	-	-	•	-	-	-
42	54	58	63	38	8	19	36,5	-	-	-	•	-	-	-
50	65	74	79	48	8	19	44,5	-	-	-	-	•	-	-
52	65	74	79	48	8	19	44,5	-	-	-	-	•	-	-
63	81	87	92	61	8	19	51	-	-	-	-	-	•	-
80*	100	106	111	78	8	19	60,5	-	-	-	-	-	-	•

* Sólo disponible para CBEC y CABEC / Only available for CBEC and CABEC

Forma de pedido / How to order: CAEC + D1*L
CBEC + D1*L
CABEC + D1*L

CASQUILLO GUÍA CAEM - CBEM - CABEM

GUIDE BUSH CAEM - CBEM - CABEM

CAEM



Material: Acero Cementación
Case Hardened Steel
Dureza / Hardness: 61-63 HRC

CBEM



Material: Bronce al aluminio
Aluminium bronze
Dureza / Hardness: HB > 190

CABEM



Material: Acero Cementación + Bronce
Case Hardened Steel + Bronze
Dureza acero / Steel hardness: 52-54 HRC

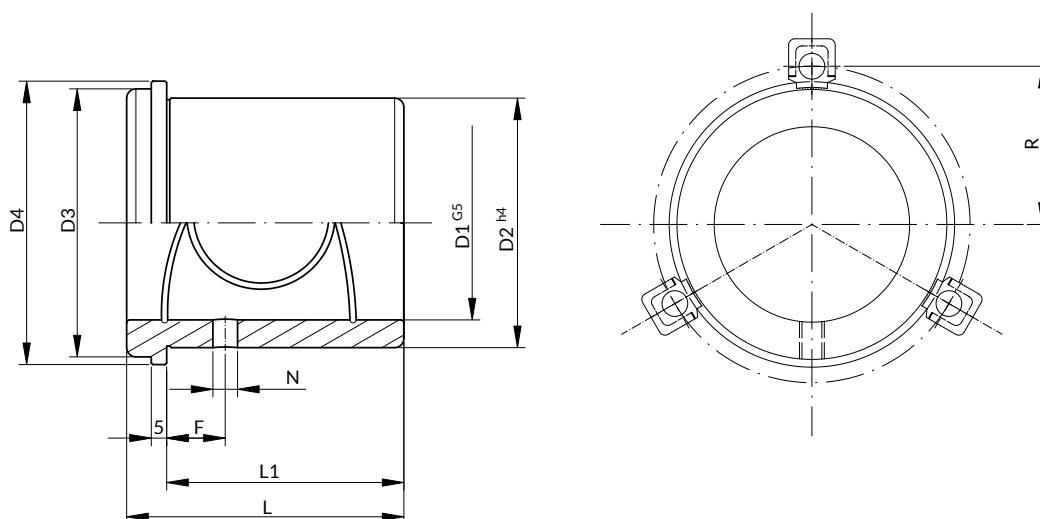

i Recomendación de montaje / Assembly recommendation
D1 ≤ 25 : 3 x BRE 6 + TCI M6x15
D1 > 25 : 3 x BRE 8 / BRE A 8 + TCI M8x20

D1	D2	D3	D4	L1	N	F	R	L						
								50	55	60	67	75	90	
18	28	29	34	37	5	8	21	•	-	-	-	-	-	-
19	28	29	34	37	5	8	21	•	-	-	-	-	-	-
24	38	39	44	42	5	12	26	-	•	-	-	-	-	-
25	38	39	44	42	5	12	26	-	•	-	-	-	-	-
30	45	48	53	47	5	16	31,5	-	-	•	-	-	-	-
32	45	48	53	47	5	16	31,5	-	-	•	-	-	-	-
40	54	58	63	54	8	19	36,5	-	-	-	•	-	-	-
42	54	58	63	54	8	19	36,5	-	-	-	•	-	-	-
50	65	74	79	62	8	19	44,5	-	-	-	-	•	-	-
52	65	74	79	62	8	19	44,5	-	-	-	-	•	-	-
63	81	87	92	77	8	19	51	-	-	-	-	-	-	•

Forma de pedido / How to order: CAEM + D1*L
CBEM + D1*L
CABEM + D1*L

CASQUILLO GUÍA CAEV - CBEV - CABEV

GUIDE BUSH CAEV - CBEV - CABEV

CAEV



Material: Acero Cementación
Case Hardened Steel
Dureza / Hardness: 61-63 HRC

CBEV



Material: Bronce al aluminio
Aluminium bronze
Dureza / Hardness: HB > 190

CABEV



Material: Acero Cementación + Bronce
Case Hardened Steel + Bronze
Dureza acero / Steel hardness: 52-54 HRC

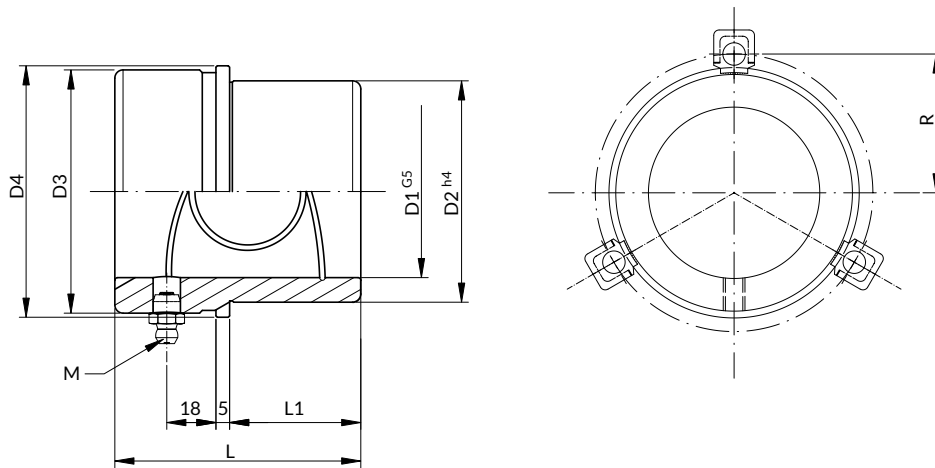

i Recomendación de montaje / Assembly recommendation
D1 ≤ 25 : 3 x BRE 6 + TCI M6x15
D1 > 25 : 3 x BRE 8 / BRE A 8 + TCI M8x20

D1	D2	D3	D4	L1	M	R	L						
							50	55	60	67	75	90	100
18	28	31	34	18	M6x1	21	•	-	-	-	-	-	-
19	28	31	34	18	M6x1	21	•	-	-	-	-	-	-
24	38	41	44	23	M10x1	26	-	•	-	-	-	-	-
25	38	41	44	23	M10x1	26	-	•	-	-	-	-	-
30	45	50	53	26	M10x1	31,5	-	-	•	-	-	-	-
32	45	50	53	26	M10x1	31,5	-	-	•	-	-	-	-
40	54	60	63	30	M10x1	36,5	-	-	-	•	-	-	-
42	54	60	63	30	M10x1	36,5	-	-	-	•	-	-	-
50	65	76	79	35	M10x1	44,5	-	-	-	-	•	-	-
52	65	76	79	35	M10x1	44,5	-	-	-	-	•	-	-
63	81	89	92	48	M10x1	51	-	-	-	-	-	•	-
80*	100	108	111	48	M10x1	60,5	-	-	-	-	-	-	•

* Sólo para CBEV y CABEV / Only for CBEV and CABEV

Forma de pedido / How to order: CAEV + D1*L
CBEV + D1*L
CABEV + D1*L

CASQUILLO GUÍA CAEL - CBEL - CABEL

GUIDE BUSH CAEL - CBEL - CABEL

CAEL



Material: Acero Cementación
Case Hardened Steel
Dureza / Hardness:
61-63 HRC

CBEL



Material: Bronce al aluminio
Aluminium bronze
Dureza / Hardness: HB > 190

CABEL



Material: Acero Cementación + Bronce
Case Hardened Steel + Bronze
Dureza acero / Steel hardness: 52-54 HRC

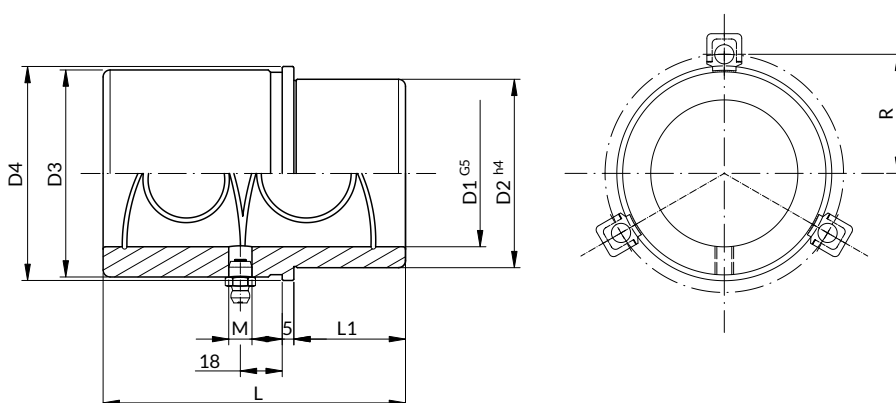

i Recomendación de montaje / Assembly recommendation
D1 ≤ 25 : 3 x BRE 6 + TCI M6x15
D1 > 25 : 3 x BRE 8 / BRE A 8 + TCI M8x20

D1	D2	D3	D4	L1	M	R	L						
							70	80	90	100	110	130	150
18	28	31	34	18	M6x1	21	•	-	-	-	-	-	-
19	28	31	34	18	M6x1	21	•	-	-	-	-	-	-
24	38	41	44	23	M10x1	26	-	•	-	-	-	-	-
25	38	41	44	23	M10x1	26	-	•	-	-	-	-	-
30	45	50	53	26	M10x1	31,5	-	-	•	-	-	-	-
32	45	50	53	26	M10x1	31,5	-	-	•	-	-	-	-
40	54	60	63	30	M10x1	36,5	-	-	-	•	-	-	-
42	54	60	63	30	M10x1	36,5	-	-	-	•	-	-	-
50	65	76	79	35	M10x1	44,5	-	-	-	-	•	-	-
52	65	76	79	35	M10x1	44,5	-	-	-	-	•	-	-
63	81	89	92	48	M10x1	51	-	-	-	-	-	•	-
80*	100	108	111	48	M10x1	60,5	-	-	-	-	-	-	•

* Sólo para CBEL y CABEL / Only for CBEL and CABEL

Forma de pedido / How to order: CAEL + D1*L
CBEL + D1*L
CABEL + D1*L

CASQUILLO GUÍA CAEX - CBEX - CABEX

GUIDE BUSH CAEX - CBEX - CABEX

CAEX



Material: Acero Cementación
Case Hardened Steel
Dureza / Hardness: 61-63 HRC

CBEX



Material: Bronce al aluminio
Aluminium bronze
Dureza / Hardness: HB > 190

CABEX



Material: Acero Cementación + Bronce
Case Hardened Steel + Bronze
Dureza acero / Steel hardness: 52-54 HRC

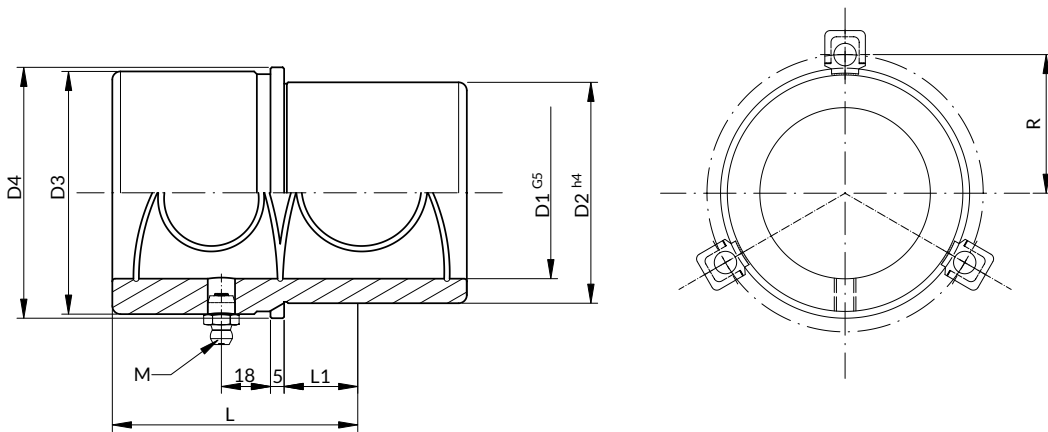

i Recomendación de montaje / Assembly recommendation
D1 ≤ 25: 3 x BRE 6 + TCI M6x15
D1 > 25: 3 x BRE 8 / BREA 8 + TCI M8x20

D1	D2	D3	D4	L1	M	R	L							
							70	80	90	100	110	130	150	
18	28	31	34	27	M6x1	21	•	-	-	-	-	-	-	-
19	28	31	34	27	M6x1	21	•	-	-	-	-	-	-	-
24	38	41	44	32	M10x1	26	-	•	-	-	-	-	-	-
25	38	41	44	32	M10x1	26	-	•	-	-	-	-	-	-
30	45	50	53	37	M10x1	31,5	-	-	•	-	-	-	-	-
32	45	50	53	37	M10x1	31,5	-	-	•	-	-	-	-	-
40	54	60	63	47	M10x1	36,5	-	-	-	•	-	-	-	-
42	54	60	63	47	M10x1	36,5	-	-	-	•	-	-	-	-
50	65	76	79	57	M10x1	44,5	-	-	-	-	•	-	-	-
52	65	76	79	57	M10x1	44,5	-	-	-	-	•	-	-	-
63	81	89	92	67	M10x1	51	-	-	-	-	-	•	-	-
80*	100	108	111	77	M10x1	60,5	-	-	-	-	-	-	-	•

* Sólo para CBEX y CABEX / Only for CBEX and CABEX

Forma de pedido / How to order: CAEX + D1*L
CBEX + D1*L
CABEX + D1*L

CASQUILLO GUÍA CAIC - CABIC - CABRC

GUIDE BUSH CAIC - CABIC - CABRC

CAIC



Material: Acero Cementación *
Case Hardened Steel *
Dureza / Hardness: 61-63 HRC

CABIC



Material: Acero Cementación + Bronce
Case Hardened Steel + Bronze
Dureza acero / Steel hardness: 52-54 HRC

CABRC



Material: C45 plaqueado en bronce
C45 bronze plated
Dureza / Hardness: 54-58 HRC

* Buenas propiedades antifricción con un coeficiente de 0,06 se desarrollan a través de la combinación de polímeros fluorados y grafito.
Good anti-seized properties and low friction coefficient (0,06) are developed through the combination of fluoropolymers and graphite.

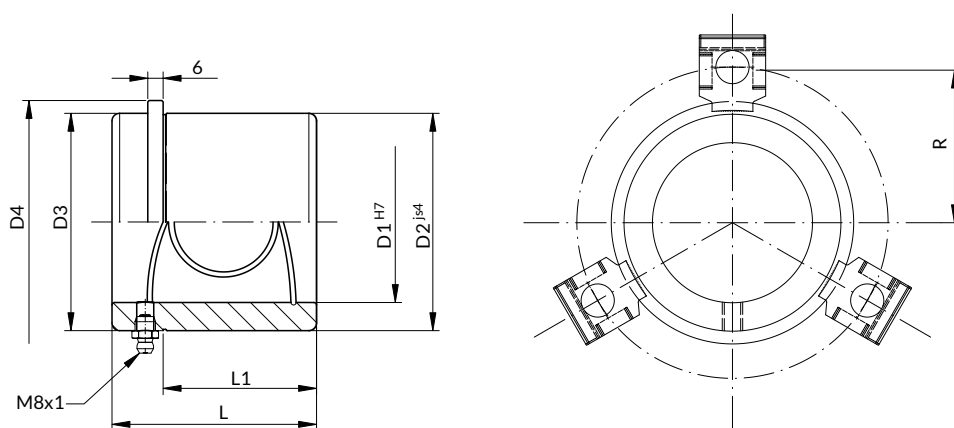

i Recomendación de montaje / Assembly recommendation
D1 < 38: 3 x BREI 6 + TCI M6x15
D1 ≥ 38: 4 x BREI 6 + TCI M6x15

Norma / Standard: ISO 9448-6

D1	D2	D3	D4	L1	R	L				
						35	42	52	65	80
19	32	32	40	23	26	•	-	-	-	-
20	32	32	40	23	26	•	-	-	-	-
24	40	40	48	23	30	•	-	-	-	-
25	40	40	48	23	30	•	-	-	-	-
30	48	48	56	30	33,5	-	•	-	-	-
32	48	48	56	30	33,5	-	•	-	-	-
38	58	58	66	37	38,5	-	-	•	-	-
40	58	58	66	37	38,5	-	-	•	-	-
48	70	70	80	47	45,5	-	-	-	•	-
50	70	70	80	47	45,5	-	-	-	•	-
60	85	85	95	60	53	-	-	-	-	•
63	85	85	95	60	53	-	-	-	-	•
80*	105	118	60	20	64,5	-	-	-	-	•

* Sólo para CABIC / Only for CABIC

Forma de pedido / How to order: CAIC + D1*L
CABIC + D1*L
CABRC + D1*L

CASQUILLO GUÍA CAIV - CABIV - CABRV GUIDE BUSH CAIV - CABIV - CABRV

CAIV



Material: Acero Cementación*
Case Hardened Steel*
Dureza / Hardness: 61-63 HRC

CABIV



Material: Acero Cementación + Bronce
Case Hardened Steel + Bronze
Dureza acero / Steel hardness: 52-54 HRC

CABRV



Material: C45 plaeado en bronce
C45 bronze plated
Dureza / Hardness: 54-58 HRC

* Buenas propiedades antifricción con un coeficiente de 0,06 se desarrollan a través de la combinación de polímeros fluorados y grafito.
Good anti-seized properties and low friction coefficient (0,06) are developed through the combination of fluropolymers and graphite.

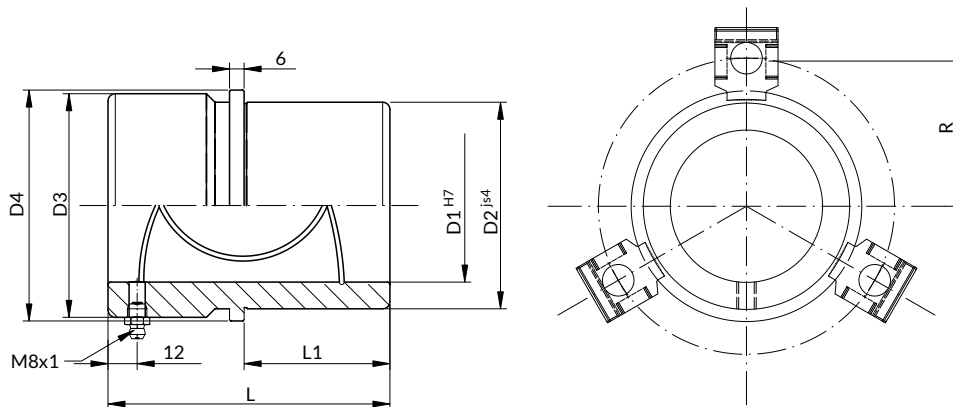

i Recomendación de montaje / Assembly recommendation
D1 < 38: 3 x BREI 6 + TCI M6x15
D1 ≥ 38: 4 x BREI 6 + TCI M6x15

Norma / Standard: ISO 9448-6

D1	D2	D3	D4	L1	R	L						
						43	59	75	82	97	116	120
19	32	39	40	23	26	•	-	-	-	-	-	-
20	32	39	40	23	26	•	-	-	-	-	-	-
24	40	46	48	23	30	-	•	-	-	-	-	-
25	40	46	48	23	30	-	•	-	-	-	-	-
30	48	53	56	30	33,5	-	-	•	-	-	-	-
32	48	53	56	30	33,5	-	-	•	-	-	-	-
38	58	63	66	37	38,5	-	-	-	•	-	-	-
40	58	63	66	37	38,5	-	-	-	•	-	-	-
48	70	77	80	47	45,5	-	-	-	-	•	-	-
50	70	77	80	47	45,5	-	-	-	-	•	-	-
60	85	92	95	60	53	-	-	-	-	-	•	-
63	85	92	95	60	53	-	-	-	-	-	•	-
80*	105	115	118	60	64,5	-	-	-	-	-	-	•

* Sólo para CABIV / Only for CABIV

Forma de pedido / How to order: CAIV + D1*L
CABIV + D1*L
CABRV + D1*L

CASQUILLO GUÍA CAIL - CABIL - CABRL

GUIDE BUSH CAIL - CABIL - CABRL

CAIL



Material: Acero Cementación*
Case Hardened Steel*
Dureza / Hardness: 61-63 HRC

CABIL



Material: Acero Cementación + Bronce
Case Hardened Steel + Bronze
Dureza acero / Steel hardness: 52-54 HRC

CABRL



Material: C45 plaqueado en bronce
C45 bronze plated
Dureza / Hardness: 54-58 HRC

* Buenas propiedades antifricción con un coeficiente de 0,06 se desarrollan a través de la combinación de polímeros fluorados y grafito.
Good anti-seized properties and low friction coefficient (0,06) are developed through the combination of fluoropolymers and graphite.

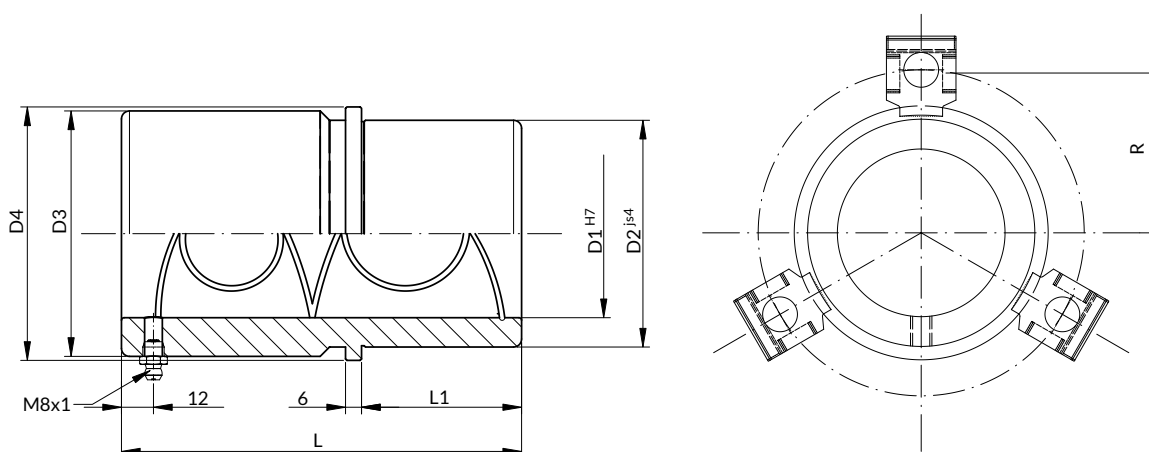

i Recomendación de montaje / Assembly recommendation
D1 < 38: 3 x BREI 6 + TCI M6x15
D1 ≥ 38: 4 x BREI 6 + TCI M6x15

Norma / Standard: ISO 9448-6

D1	D2	D3	D4	L1	R	L					
						59	79	93	108	127	150
19	32	39	40	23	26	•	-	-	-	-	-
20	32	39	40	23	26	•	-	-	-	-	-
24	40	46	48	23	30	-	•	-	-	-	-
25	40	46	48	23	30	-	•	-	-	-	-
30	48	53	56	30	33,5	-	-	•	-	-	-
32	48	53	56	30	33,5	-	-	•	-	-	-
38	58	63	66	37	38,5	-	-	-	•	-	-
40	58	63	66	37	38,5	-	-	-	•	-	-
48	70	77	80	47	45,5	-	-	-	-	•	-
50	70	77	80	47	45,5	-	-	-	-	•	-
60	85	92	95	60	53	-	-	-	-	-	•
63	85	92	95	60	53	-	-	-	-	-	•
80*	105	115	118	60	64,5	-	-	-	-	-	•

* Sólo para CABIL / Only for CABIL

Forma de pedido / How to order: CAIL + D1*L
CABIL + D1*L
CABRL + D1*L

CASQUILLO GUÍA CASC - CABSC

GUIDE BUSH CASC - CABSC

CASC



Material: Acero Cementación*
Case Hardened Steel*
Dureza / Hardness: 61-63 HRC

CABSC



Material: Acero Cementación + Bronce
Case Hardened Steel + Bronze
Dureza acero / Steel hardness: 52-54 HRC

* Buenas propiedades antifricción con un coeficiente de 0,06 se desarrollan a través de la combinación de polímeros fluorados y grafito.
Good anti-seized properties and low friction coefficient (0,06) are developed through the combination of fluoropolymers and graphite.

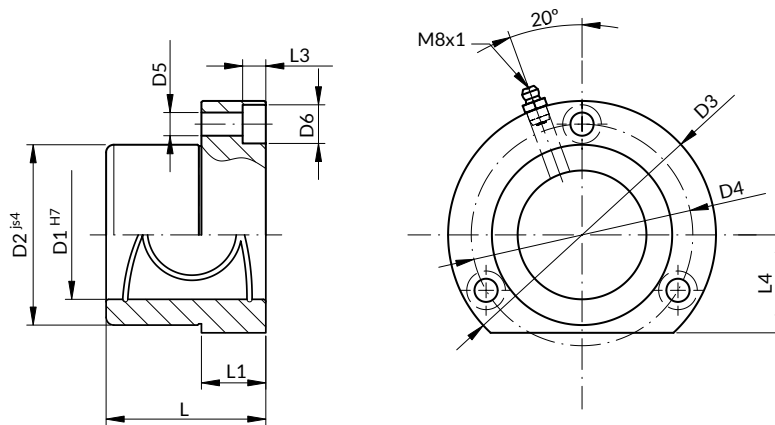

i Recomendación de montaje / Assembly recommendation
D1 ≤ 16 = 3 x DIN 6912
D1 > 16 = 3 x DIN 912

Norma / Standard: ISO 9448-4

D1	D2	D3	D4	D5	D6	L1	L3	L4	L				
									29	38	45	55	62
15	28	45	35	4,5	8	23	3,4	15	•	-	-	-	-
16	28	45	35	4,5	8	23	3,4	15	•	-	-	-	-
19	32	50	40	4,5	8	23	4,6	18	-	•	-	-	-
20	32	50	40	4,5	8	23	4,6	18	-	•	-	-	-
24	40	63	50	5,5	10	23	5,7	23	-	•	-	-	-
25	40	63	50	5,5	10	23	5,7	23	-	•	-	-	-
30	48	72	58	5,5	10	30	5,7	28	-	-	•	-	-
32	48	72	58	5,5	10	30	5,7	28	-	-	•	-	-
38	58	85	70	6,6	11	30	6,8	33	-	-	-	•	-
40	58	85	70	6,6	11	30	6,8	33	-	-	-	•	-
48	70	104	86	9	15	37	9	38	-	-	-	-	•
50	70	104	86	9	15	37	9	38	-	-	-	-	•

Forma de pedido / How to order: CASC + D1*L
CABSC + D1*L

CASQUILLO GUÍA CASV - CABS

GUIDE BUSH CASV - CABS

CASV



Material: Acero Cementación *
Case Hardened Steel *
Dureza / Hardness: 61-63 HRC

CABS



Material: Acero Cementación + Bronce
Case Hardened Steel + Bronze
Dureza acero / Steel hardness: 52-54 HRC

* Buenas propiedades antifricción con un coeficiente de 0,06 se desarrollan a través de la combinación de polímeros fluorados y grafito.
Good anti-seized properties and low friction coefficient (0,06) are developed through the combination of fluropolymers and graphite.

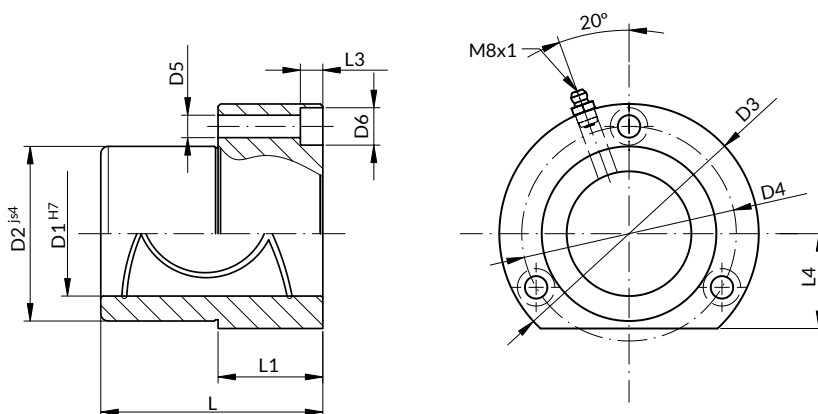

i Recomendación de montaje / Assembly recommendation
D1 ≤ 16 = 3 x DIN 6912
D1 > 16 = 3 x DIN 912

Norma / Standard: ISO 9448-4

D1	D2	D3	D4	D5	D6	L1	L3	L4	L					
									36	45	55	62	67	89
15	28	45	35	4,5	8	30	3,4	15	•	-	-	-	-	-
16	28	45	35	4,5	8	30	3,4	15	•	-	-	-	-	-
19	32	50	40	4,5	8	30	4,6	18	-	•	-	-	-	-
20	32	50	40	4,5	8	30	4,6	18	-	•	-	-	-	-
24	40	63	50	5,5	10	30	5,7	23	-	-	•	-	-	-
25	40	63	50	5,5	10	30	5,7	23	-	-	•	-	-	-
30	48	72	58	5,5	10	37	5,7	28	-	-	-	•	-	-
32	48	72	58	5,5	10	37	5,7	28	-	-	-	•	-	-
38	58	85	70	6,6	11	37	6,8	33	-	-	-	-	•	-
40	58	85	70	6,6	11	37	6,8	33	-	-	-	-	•	-
48	70	104	86	9	15	47	9	38	-	-	-	-	-	•
50	70	104	86	9	15	47	9	38	-	-	-	-	-	•
60	85	120	100	9	15	47	9	46	-	-	-	-	-	•
63	85	120	100	9	15	47	9	46	-	-	-	-	-	•

Forma de pedido / How to order: CASCV + D1*L
CABS + D1*L

CASQUILLO GUÍA CASL - CABSL

GUIDE BUSH CASL - CABSL

CASL



Material: Acero Cementación *
Case Hardened Steel *
Dureza / Hardness: 61-63 HRC

CABSL



Material: Acero Cementación + Bronce
Case Hardened Steel + Bronze
Dureza acero / Steel hardness: 52-54 HRC

* Buenas propiedades antifricción con un coeficiente de 0,06 se desarrollan a través de la combinación de polímeros fluorados y grafito
Good anti-seized properties and low friction coefficient (0,06) are developed through the combination of fluoropolymers and graphite.

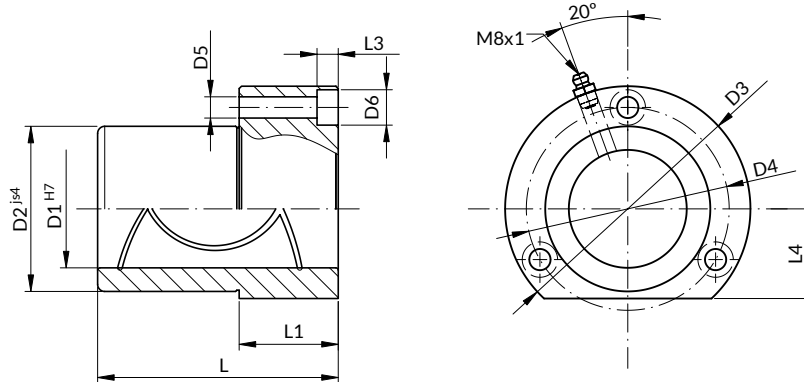

i Recomendación de montaje / Assembly recommendation
3 x DIN 912

Norma / Standard: ISO 9448-4

D1	D2	D3	D4	D5	D6	L1	L3	L4	L					
									52	62	72	77	102	125
19	32	50	40	4,5	8	37	4,6	18	•	-	-	-	-	-
20	32	50	40	4,5	8	37	4,6	18	•	-	-	-	-	-
24	40	63	50	5,5	10	37	5,7	23	-	•	-	-	-	-
25	40	63	50	5,5	10	37	5,7	23	-	•	-	-	-	-
30	48	72	58	5,5	10	47	5,7	28	-	-	•	-	-	-
32	48	72	58	5,5	10	47	5,7	28	-	-	•	-	-	-
38	58	85	70	6,6	11	47	6,8	33	-	-	-	•	-	-
40	58	85	70	6,6	11	47	6,8	33	-	-	-	•	-	-
48	70	104	86	9	15	60	9	38	-	-	-	-	•	-
50	70	104	86	9	15	60	9	38	-	-	-	-	•	-
60	85	120	100	9	15	60	9	46	-	-	-	-	•	-
63	85	120	100	9	15	60	9	46	-	-	-	-	•	-
80	105	148	125	11	18	75	11	56	-	-	-	-	-	•

Forma de pedido / How to order: CASL + D1*L
CABSL + D1*L

CASQUILLO GUÍA PARA JAULA DE BOLAS CJC

GUIDE BUSH FOR BALL CAGE CJC

Material: Acero Cementación / Case Hardened Steel
Dureza / Hardness: 61-63 HRC

STOCK

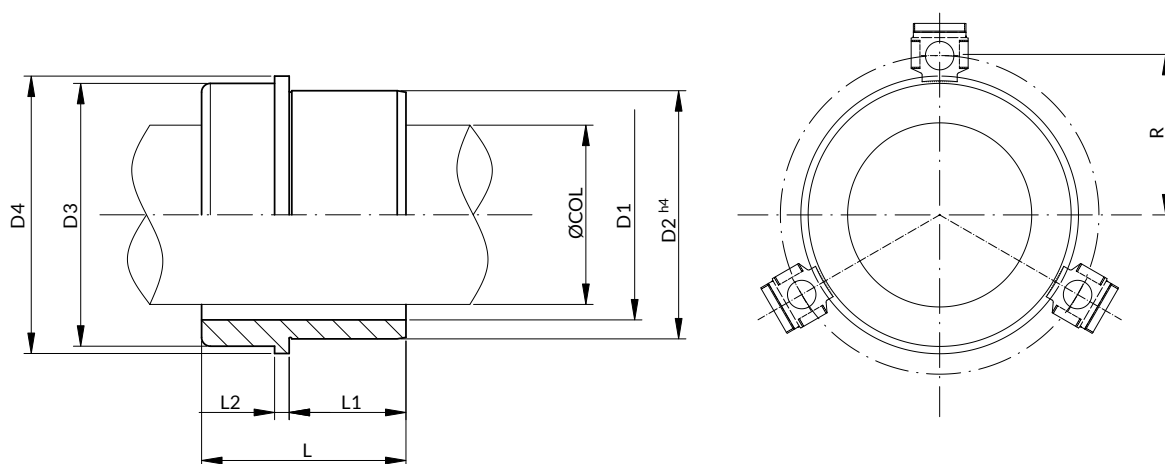

i Recomendación de montaje / Assembly recommendation
D1 ≤ 25: 3 x BRE 6 + TCI M6x15
D1 > 25: 3 x BRE 8 / BRE A 8 + TCI M8x20

Ø COL	D1	D2	D3	D4	L1	L2	R	L							
								31	33	40	45	48	57	70	100
15	21	28	30	34	15	5	21,5	•	-	-	-	-	-	-	-
16	22	28	30	34	15	5	21,5	•	-	-	-	-	-	-	-
18	24	32	34	38	17	5	23,5	-	•	-	-	-	-	-	-
19	25	32	34	38	17	5	23,5	-	•	-	-	-	-	-	-
24	30	40	43	48	22	5	29	-	-	•	-	-	-	-	-
25	31	40	43	48	22	5	29	-	-	•	-	-	-	-	-
30	38	48	53	58	27	5	34	-	-	-	•	-	-	-	-
32	40	48	53	58	27	5	34	-	-	-	•	-	-	-	-
40	48	58	66	72	30	5	41	-	-	-	-	•	-	-	-
42	50	58	66	72	30	5	41	-	-	-	-	•	-	-	-
50	58	68	77	82	35	5	46	-	-	-	-	-	•	-	-
52	60	68	77	82	35	5	46	-	-	-	-	-	•	-	-
60	72	85	90	95	40	5	52,5	-	-	-	-	-	-	•	-
63	75	85	90	95	40	5	52,5	-	-	-	-	-	-	•	-
80	92	100	112	120	55	6,5	65	-	-	-	-	-	-	-	•

Forma de pedido: CJC + D1*L
How to order: CJC + D1*L

CASQUILLO GUÍA PARA JAULA DE BOLAS CJV GUIDE BUSH FOR BALL CAGE CJV

Material: Acero Cementación / Case Hardened Steel
Dureza / Hardness: 62-63 HRC

STOCK

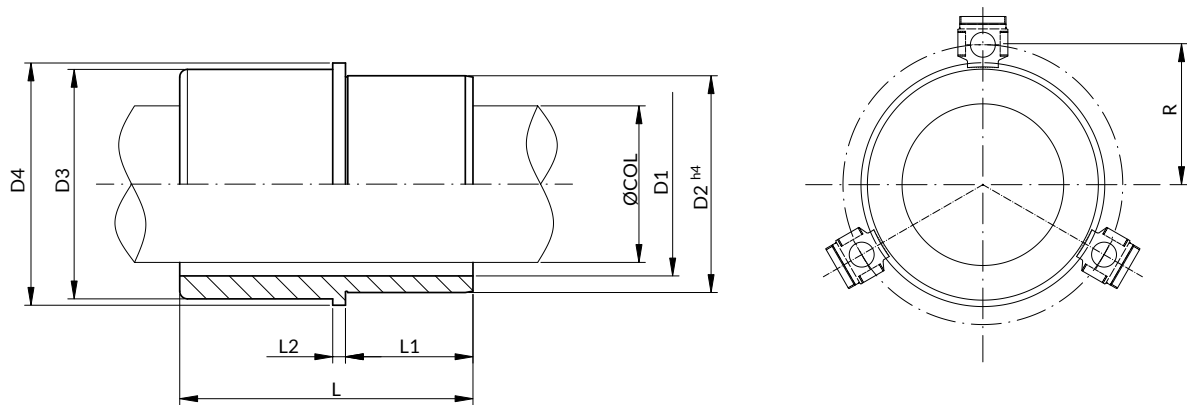

i Recomendación de montaje / Assembly recommendation
D1 ≤ 75: 3 x BRE 6 + TCI M6x15
D1 > 75: 3 x BRE 8 / BREA 8 + TCI M8x20

Ø COL	D1	D2	D3	D4	L1	L2	R	L								
								50	60	65	75	80	85	100	115	125
15	21	28	30	34	20	5	21,5	•	-	-	-	-	-	-	-	-
16	22	28	30	34	20	5	21,5	•	-	-	-	-	-	-	-	-
18	24	32	34	38	25	5	23,5	-	•	-	-	-	-	-	-	-
19	25	32	34	38	25	5	23,5	-	•	-	-	-	-	-	-	-
24	30	40	43	48	30	5	29	-	•	-	•	-	-	-	-	-
25	31	40	43	48	30	5	29	-	•	-	•	-	-	-	-	-
30	38	48	53	58	30	5	34	-	•	-	-	•	-	-	-	-
32	40	48	53	58	30	5	34	-	•	-	-	•	-	-	-	-
40	48	58	66	72	35	5	41	-	-	•	-	-	•	-	-	-
42	50	58	66	72	35	5	41	-	-	•	-	-	•	-	-	-
50	58	68	77	82	45	5	46	-	-	-	•	-	-	•	-	-
52	60	68	77	82	45	5	46	-	-	-	•	-	-	•	-	-
60	72	85	90	95	50	5	52,5	-	-	-	-	-	-	-	•	-
63	75	85	90	95	50	5	52,5	-	-	-	-	-	-	-	•	-
80	92	100	112	120	55	7	65	-	-	-	-	-	-	-	-	•

Forma de pedido: CJV + D1*L

How to order: CJV + D1*L

CASQUILLO GUÍA PARA JAULA DE BOLAS C JL

GUIDE BUSH FOR BALL CAGE C JL

Material: Acero Cementación / Case Hardened Steel
Dureza / Hardness: 62-63 HRC

STOCK

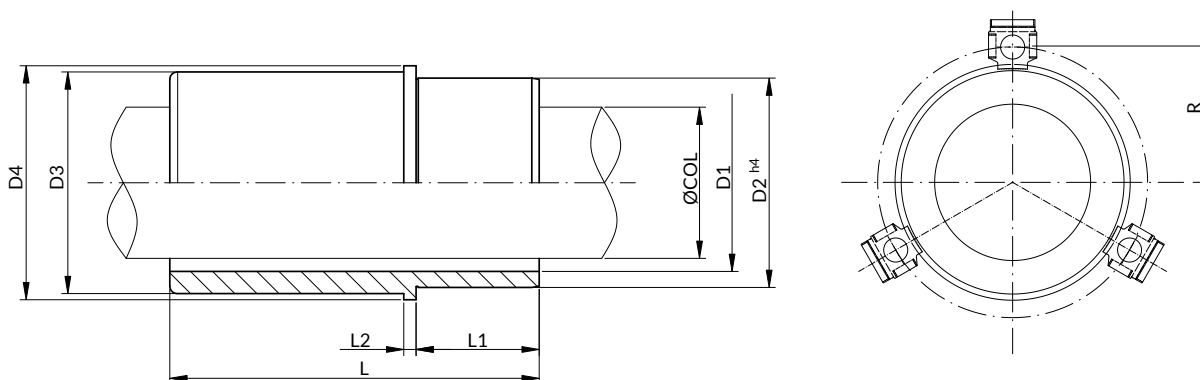

i Recomendación de montaje / Assembly recommendation
D1 ≤ 75 : 3 x BRE 6 + TCI M6x15
D1 > 75 : 3 x BRE 8 / BREA 8 + TCI M8x20

Ø COL	D1	D2	D3	D4	L1	L2	R	L								
								105	110	115	125	130	134	145	150	180
18	24	32	34	38	25	5	23,5	•	-	-	•	-	-	-	-	-
19	25	32	34	38	25	5	23,5	•	-	-	•	-	-	-	-	-
24	30	40	43	48	30	5	29	-	•	-	-	•	-	-	-	-
25	31	40	43	48	30	5	29	-	•	-	-	•	-	-	-	-
30	38	48	53	58	30	5	34	-	•	-	-	•	-	-	-	-
32	40	48	53	58	30	5	34	-	•	-	-	•	-	-	-	-
40	48	58	66	72	35	5	41	-	-	•	-	-	•	-	-	-
42	50	58	66	72	35	5	41	-	-	•	-	-	•	-	-	-
50	58	68	77	82	45	5	46	-	-	-	•	-	-	•	-	-
52	60	68	77	82	45	5	46	-	-	-	•	-	-	•	-	-
60	72	85	90	95	50	5	52,5	-	-	-	-	•	-	-	•	-
63	75	85	90	95	50	5	52,5	-	-	-	-	•	-	-	•	-
80	92	100	112	120	55	7	65	-	-	-	-	-	-	-	-	•

Forma de pedido: C JL + D1*L
How to order: C JL + D1*L

CASQUILLO GUÍA PARA JAULA DE BOLAS CJA GUIDE BUSH FOR BALL CAGE CJA

Material: Acero Cementación / Case Hardened Steel
Dureza / Hardness: 62-63 HRC

STOCK

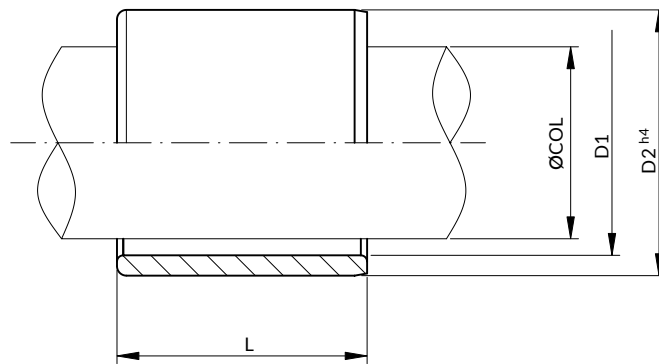

Ø COL	D1	D2	L										
			35	55	60	65	70	75	80	85	95	115	
15	21	28	•	-	•	-	-	-	-	-	-	-	-
17	23	29	•	-	•	-	-	-	-	-	-	-	-
18	24	32	-	•	-	•	-	-	-	-	-	-	-
20	26	33	-	•	-	•	-	-	-	-	-	-	-
24	30	40	-	•	-	-	•	-	-	-	-	-	-
26	32	41	-	•	-	-	•	-	-	-	-	-	-
30	38	48	-	-	•	-	-	•	-	-	-	-	-
32	40	49	-	-	•	-	-	•	-	-	-	-	-
40	48	58	-	-	-	-	•	-	-	•	-	-	-
43	51	59	-	-	-	-	•	-	-	•	-	-	-
50	58	68	-	-	-	-	-	-	•	-	•	-	-
53	61	69	-	-	-	-	-	-	•	-	•	-	-
60	72	85	-	-	-	-	-	-	•	-	•	-	-
63	75	86	-	-	-	-	-	-	•	-	•	-	-
80	92	100	-	-	-	-	-	-	-	-	•	•	-

Forma de pedido: CJA + D1*L

How to order: CJA + D1*L

CASQUILLO PARA JAULA DE BOLAS CJCN GUIDE BUSH FOR BALL CAGE CJCN

Material: Acero para cojinetes a bolas / Steel for ball bearing cage
Dureza / Hardness: 62 ± 2 HRC

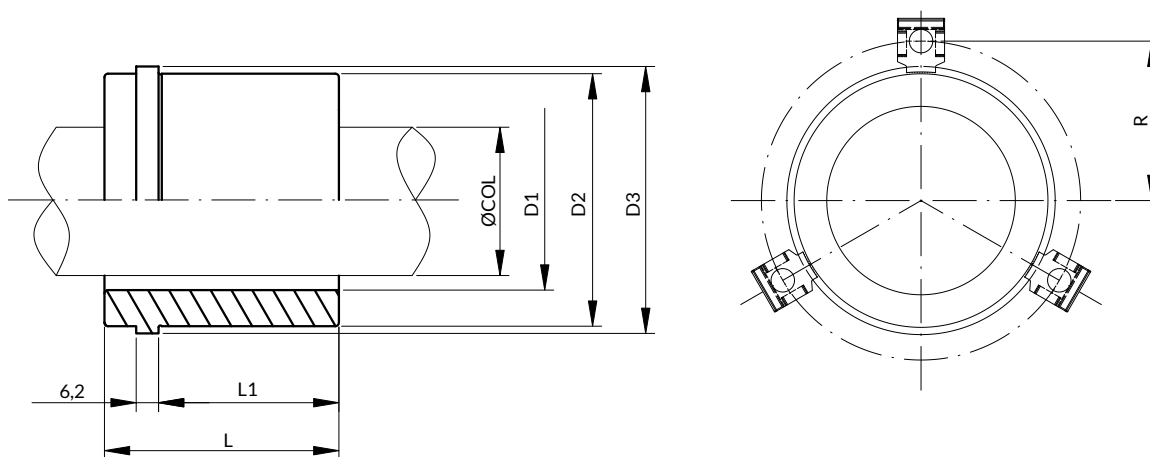

i Recomendación de montaje con brida BREI 6 (x3)
Assembly recommendation with BREI 6 clamp (x3)

Ø COL	D1	D2	D3	L1	R	L			
						40	45	56	65
24	30	40	44	18	29	•	-	-	-
25	31	40	44	18	29	•	-	-	-
30	38	48	52	23	33	-	•	-	-
32	40	48	52	23	33	-	•	-	-
40	48	58	62	27	38	-	-	•	-
42	50	58	62	27	38	-	-	•	-
50	58	70	74	50	44	-	-	-	•

Forma de pedido: CJCN + D*L
How to order: CJCN + D*L

CASQUILLO PARA JAULA DE BOLAS CJVN GUIDE BUSH FOR BALL CAGE CJVN

Material: Acero para cojinetes a bolas / Steel for ball bearing cage
Dureza / Hardness: HB \geq 179

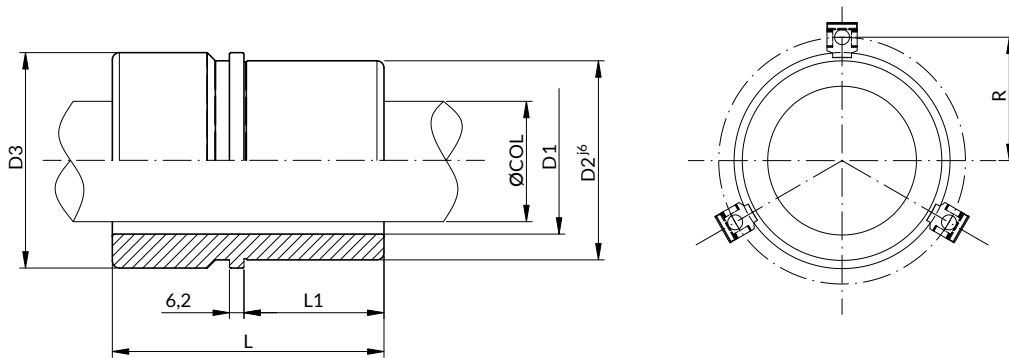

i Recomendación de montaje con brida BREI 6 (x3)
Assembly recommendation with BREI 6 clamp (x3)

Ø COL	D1	D2	D3	R	L1	L					
						64	70	76	85	100	110
24	30	40	44	29	34	•	•	-	-	-	-
25	31	40	44	29	34	•	•	-	-	-	-
30	38	48	52	33	39	•	-	-	•	-	-
32	40	48	52	33	39	•	-	-	•	-	-
40	48	58	62	38	49	-	-	•	-	•	-
42	50	58	62	38	49	-	-	•	-	•	-
50	58	70	74	44	54	-	-	-	-	-	•

Forma de pedido: CJVN + D1*L
How to order: CJVN + D1*L

CASQUILLO PARA JAULA DE BOLAS SUSPENDIDA CJSN GUIDE BUSH FOR HANGING BALL CJSN

Material: Acero para cojinetes a bolas / Steel for ball bearing cage
Dureza / Hardness: 62 ± 2 HRC

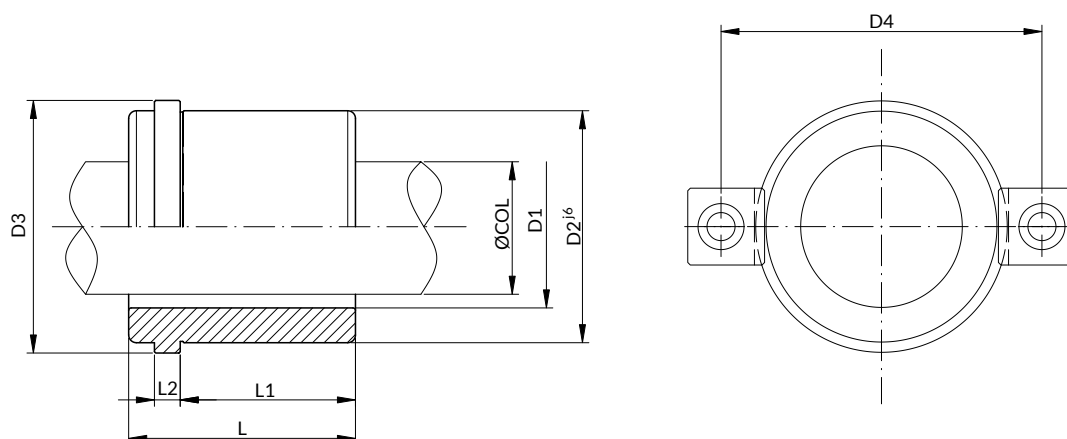

i Recomendación de montaje / Assembly recommendation
 \varnothing COL = 50: 3x BREI 6 + TCI M6x15
 \varnothing COL \geq 63: 3x BRM50 + TCC M8x20

Ø COL	D1	D2	D3	D4	L2	L						
						88	90	96	98	100	116	118
50	58	70	74	88	6,2	-	L1=72	-	-	L1=82	L1=98	-
50	58	80	90	98	6	-	-	L1=78	-	-	-	-
63	75	90	98	125	10	L1=68	-	-	L1=78	-	-	L1=98
80	92	112	120	147	10	L1=68	-	-	L1=78	-	-	L1=98

Forma de pedido: CJSN + D1*L
How to order: CJSN + D1*L

CASQUILLO GUÍA PARA JAULA DE BOLAS CJIC GUIDE BUSH FOR BALL CAGE CJIC

Material: Acero Cementación / Case Hardened Steel
Dureza / Hardness: 62-63 HRC

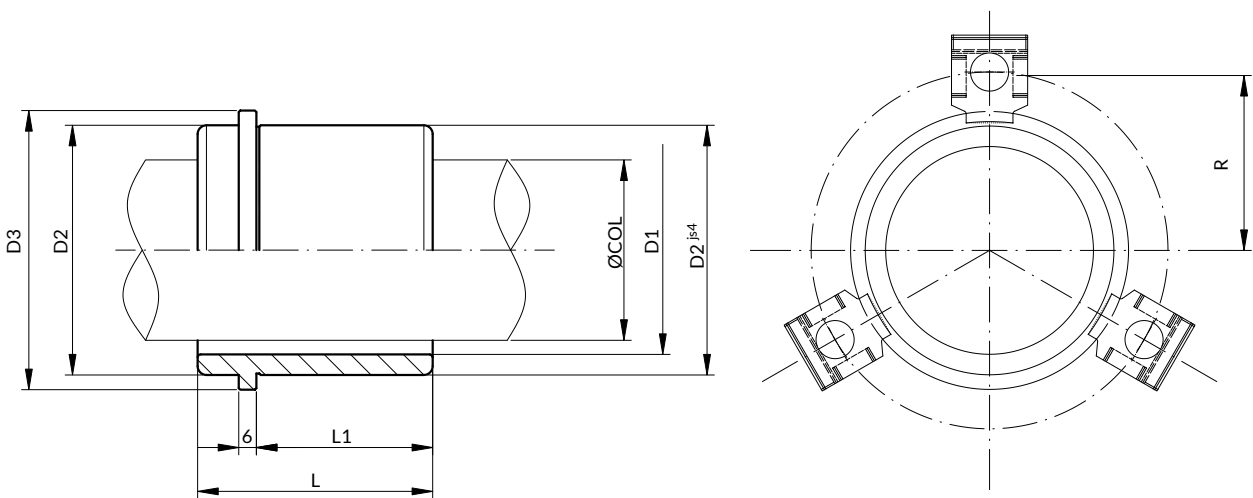

i Recomendación de montaje / Assembly recommendation
D1 < 38: 3 x BREI 6 + TCI M6x15
D1 ≥ 38: 4 x BREI 6 + TCI M6x15

Norma / Standard: ISO 9448-7

Ø COL	D1	D2	D3	L1	R	L				
						35	42	52	65	80
19	25	32	40	23	26	•	-	-	-	-
20	26	32	40	23	26	•	-	-	-	-
24	30	40	48	23	30	•	-	-	-	-
25	31	40	48	23	30	•	-	-	-	-
30	38	48	56	30	33,5	-	•	-	-	-
32	40	48	56	30	33,5	-	•	-	-	-
38	46	58	66	37	38,5	-	-	•	-	-
40	48	58	66	37	38,5	-	-	•	-	-
48	56	70	80	47	45,5	-	-	-	•	-
50	58	70	80	47	45,5	-	-	-	•	-
60	68	85	95	60	53	-	-	-	-	•
63	71	85	95	60	53	-	-	-	-	•
80	92	105	118	60	64,5	-	-	-	-	•

Forma de pedido: CJIC + D1*L

How to order: CJIC + D1*L

CASQUILLO GUÍA PARA JAULA DE BOLAS CJIM GUIDE BUSH FOR BALL CAGE CJIM

Material: Acero Cementación / Case Hardened Steel
Dureza / Hardness: 62-63 HRC

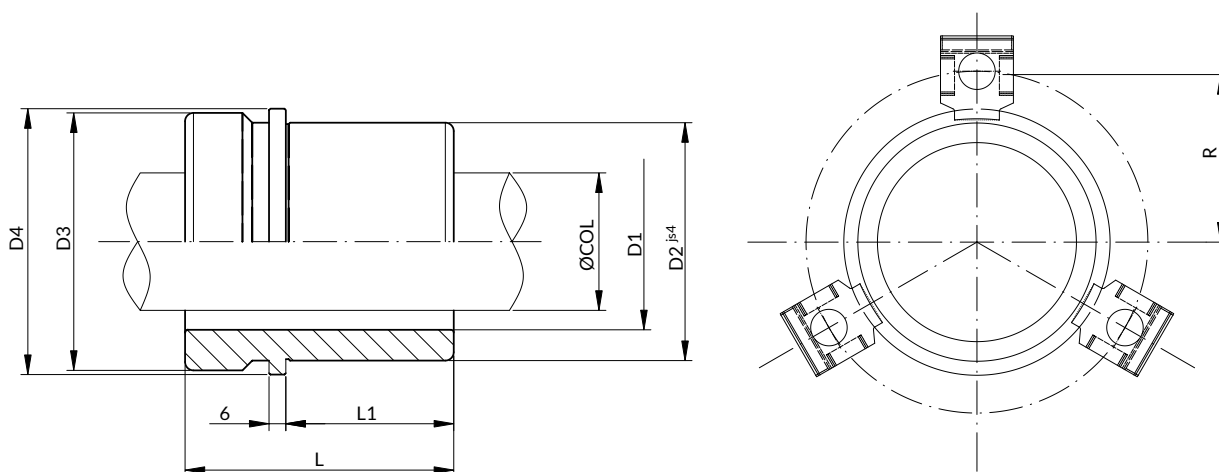

i Recomendación de montaje / Assembly recommendation
D1 < 38 : 3 x BREI 6 + TCI M6x15
D1 ≥ 38 : 4 x BREI 6 + TCI M6x15

Norma / Standard: ISO 9448-7

Ø COL	D1	D2	D3	D4	L1	R	L			
							55	69	79	96
24	30	40	46	48	30	30	•	-	-	-
25	31	40	46	48	30	30	•	-	-	-
30	38	48	53	56	37	33,5	-	•	-	-
32	40	48	53	56	37	33,5	-	•	-	-
38	46	58	63	66	47	38,5	-	-	•	-
40	48	58	63	66	47	38,5	-	-	•	-
48	56	70	77	80	60	45,5	-	-	-	•
50	58	70	77	80	60	45,5	-	-	-	•

Forma de pedido: CJIM + D1*L
How to order: CJIM + D1*L

CASQUILLO GUÍA PARA JAULA DE BOLAS CJIV GUIDE BUSH FOR BALL CAGE CJIV

Material: Acero Cementación / Case Hardened Steel
Dureza / Hardness: 62-63 HRC

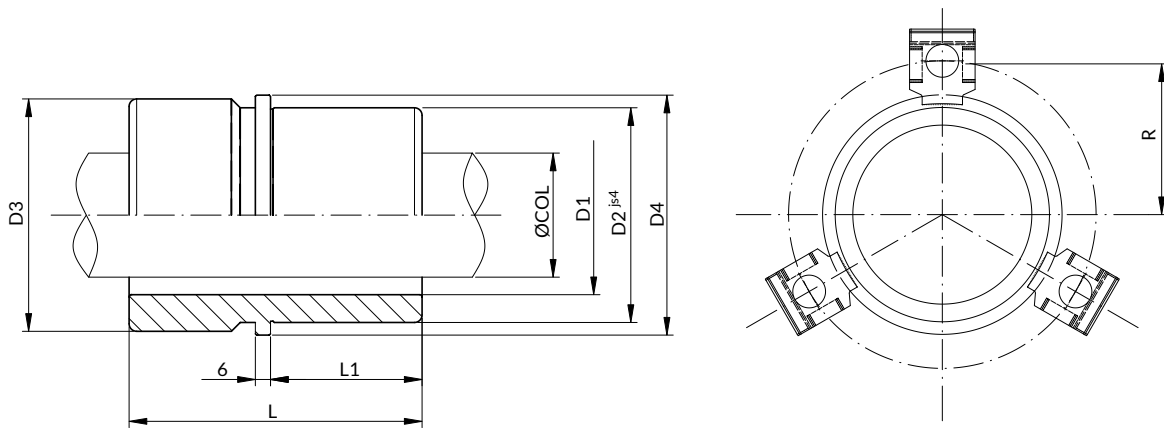

i Recomendación de montaje / Assembly recommendation
D1 < 38: 3 x BREI 6 + TCI M6x15
D1 ≥ 38: 4 x BREI 6 + TCI M6x15

Norma / Standard: ISO 9448-7

Ø COL	D1	D2	D3	D4	L1	R	L						
							43	59	75	82	97	116	120
19	25	32	39	40	23	26	•	-	-	-	-	-	-
20	26	32	39	40	23	26	•	-	-	-	-	-	-
24	30	40	46	48	23	30	-	•	-	-	-	-	-
25	31	40	46	48	23	30	-	•	-	-	-	-	-
30	38	48	53	56	30	33,5	-	-	•	-	-	-	-
32	40	48	53	56	30	33,5	-	-	•	-	-	-	-
38	46	58	63	66	37	38,5	-	-	-	•	-	-	-
40	48	58	63	66	37	38,5	-	-	-	•	-	-	-
48	56	70	77	80	47	45,5	-	-	-	-	•	-	-
50	58	70	77	80	47	45,5	-	-	-	-	•	-	-
60	68	85	92	95	60	53	-	-	-	-	-	•	-
63	71	85	92	95	60	53	-	-	-	-	-	•	-
80	92	105	115	118	60	64,5	-	-	-	-	-	-	•

Forma de pedido: CJIV + D1*L
How to order: CJIV + D1*L

CASQUILLO GUÍA PARA JAULA DE BOLAS CJIL GUIDE BUSH FOR BALL CAGE CJIL

Material: Acero Cementación / Case Hardened Steel
Dureza / Hardness: 62-63 HRC

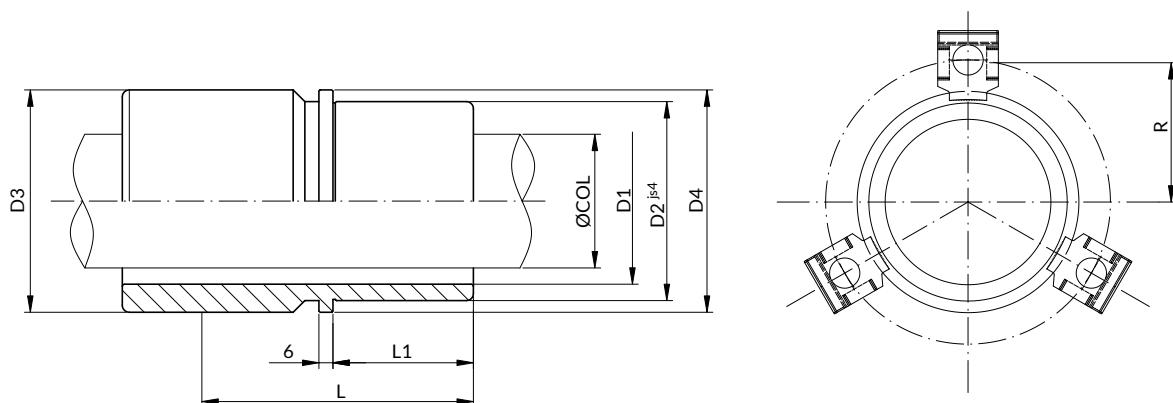

i Recomendación de montaje / Assembly recommendation
D1 < 38 : 3 x BREI 6 + TCI M6x15
D1 ≥ 38 : 4 x BREI 6 + TCI M6x15

Norma / Standard: ISO 9448-7

Ø COL	D1	D2	D3	D4	L1	R	L			
							80	93	110	131
24	30	40	48	46	30	30	•	-	-	-
25	31	40	48	46	30	30	•	-	-	-
30	38	48	56	53	37	33,5	-	•	-	-
32	40	48	56	53	37	33,5	-	•	-	-
38	46	58	66	63	47	38,5	-	-	•	-
40	48	58	66	63	47	38,5	-	-	•	-
48	56	70	80	77	60	45,5	-	-	-	•
50	58	70	80	77	60	45,5	-	-	-	•

Forma de pedido: CJIL + D1*L
How to order: CJIL + D1*L

CASQUILLO GUÍA PARA JAULA DE BOLAS CJIX GUIDE BUSH FOR BALL CAGE CJIX

Material: Acero Cementación / Case Hardened Steel
Dureza / Hardness: 62-63 HRC

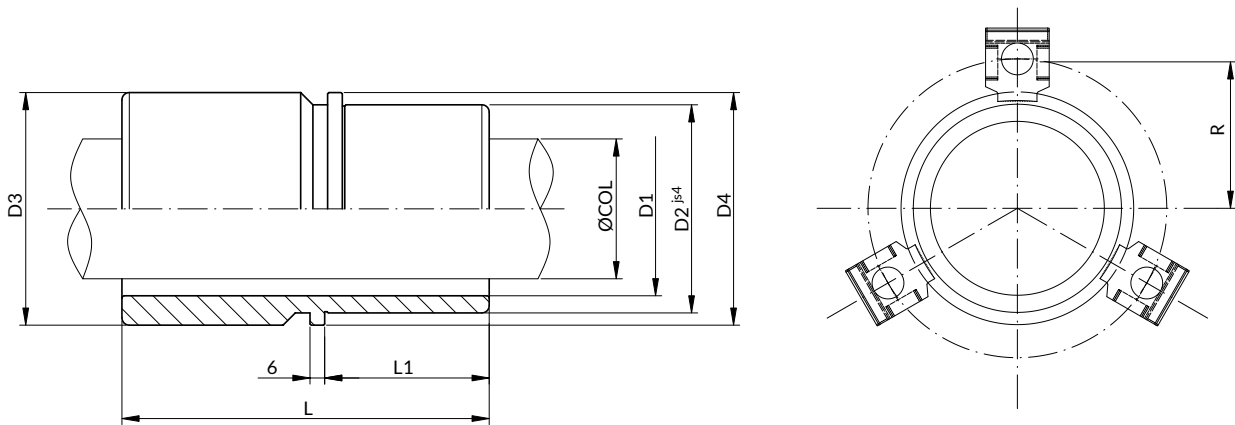

i Recomendación de montaje / Assembly recommendation
D1 < 38 : 3 x BREI 6 + TCI M6x15
D1 ≥ 38 : 4 x BREI 6 + TCI M6x15

Norma / Standard: ISO 9448-7

Ø COL	D1	D2	D3	D4	L1	R	L					
							59	79	93	108	127	150
19	25	32	40	39	23	26	•	-	-	-	-	-
20	26	32	40	39	23	26	•	-	-	-	-	-
24	30	40	48	46	23	30	-	•	-	-	-	-
25	31	40	48	46	23	30	-	•	-	-	-	-
30	38	48	56	53	30	33,5	-	-	•	-	-	-
32	40	48	56	53	30	33,5	-	-	•	-	-	-
38	46	58	66	63	37	38,5	-	-	-	•	-	-
40	48	58	66	63	37	38,5	-	-	-	•	-	-
48	56	70	80	77	47	45,5	-	-	-	-	•	-
50	58	70	80	77	47	45,5	-	-	-	-	•	-
60	68	85	95	92	60	53	-	-	-	-	-	•
63	71	85	95	92	60	53	-	-	-	-	-	•
80	92	105	118	115	60	64,5	-	-	-	-	-	•

Forma de pedido: CJIX + D1*L
How to order: CJIX + D1*L

CASQUILLO GUÍA PARA JAULA DE BOLAS CJSC GUIDE BUSH FOR BALL CAGE CJSC

Material: Acero Cementación / Case Hardened Steel
Dureza / Hardness: 62-63 HRC

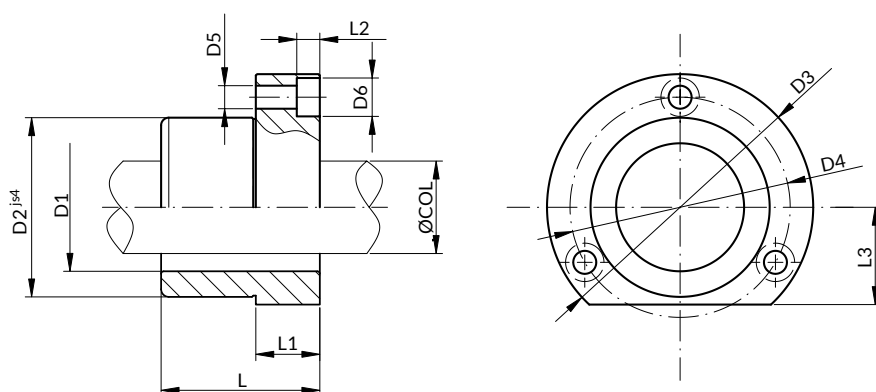

i Recomendación de montaje / Assembly recommendation
 $\varnothing \text{COL} \leq 16 = 3 \times \text{DIN 6912}$
 $\varnothing \text{COL} > 16 = 3 \times \text{DIN 912}$

Norma / Standard: DIN 9831 / ISO 9448-5

Ø COL	D1	D2	D3	D4	D5	D6	L1	L2	L3	L				
										29	38	45	55	62
15	21	28	45	35	4,5	8	6	3,4	15	•	-	-	-	-
16	22	28	45	35	4,5	8	6	3,4	15	•	-	-	-	-
19	25	32	50	40	4,5	8	15	4,6	18	-	•	-	-	-
20	26	32	50	40	4,5	8	15	4,6	18	-	•	-	-	-
24	30	40	63	50	5,5	10	15	5,7	23	-	•	-	-	-
25	31	40	63	50	5,5	10	15	5,7	23	-	•	-	-	-
30	38	48	72	58	5,5	10	15	5,7	28	-	-	•	-	-
32	40	48	72	58	5,5	10	15	5,7	28	-	-	•	-	-
38	46	58	85	70	6,6	11	25	6,8	33	-	-	-	•	-
40	48	58	85	70	6,6	11	25	6,8	33	-	-	-	•	-
48	56	70	104	86	9	15	25	9	38	-	-	-	-	•
50	58	70	104	86	9	15	25	9	38	-	-	-	-	•

Forma de pedido: CJSC + D1*L
How to order: CJSC + D1*L

CASQUILLO GUÍA PARA JAULA DE BOLAS CJSV GUIDE BUSH FOR BALL CAGE CJSV

Material: Acero Cementación / Case Hardened Steel
Dureza / Hardness: 62-63 HRC

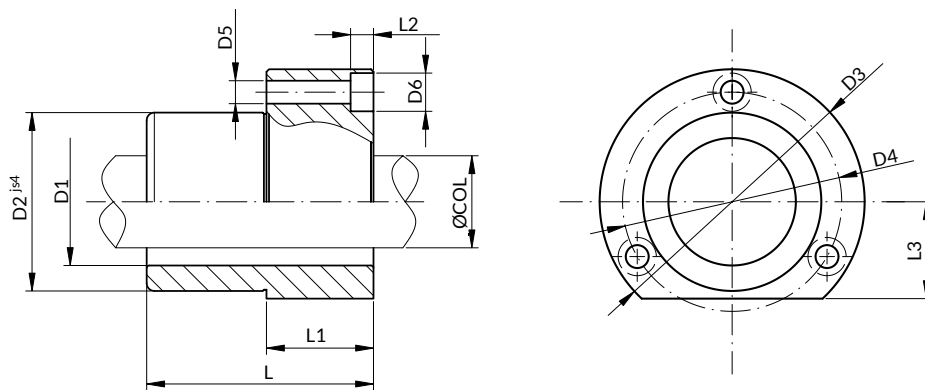

i Recomendación de montaje / Assembly recommendation
 $\varnothing \text{ COL} \leq 16 = 3 \times \text{DIN 6912}$
 $\varnothing \text{ COL} > 16 = 3 \times \text{DIN 912}$

Norma / Standard: DIN 9831 / ISO 9448-5

Ø COL	D1	D2	D3	D4	D5	D6	L1	L2	L3	L					
										36	45	55	62	67	89
15	21	28	45	35	4,5	8	6	3,4	15	•	-	-	-	-	-
16	22	28	45	35	4,5	8	6	3,4	15	•	-	-	-	-	-
19	25	32	50	40	4,5	8	15	4,6	18	-	•	-	-	-	-
20	26	32	50	40	4,5	8	15	4,6	18	-	•	-	-	-	-
24	30	40	63	50	5,5	10	25	5,7	23	-	-	•	-	-	-
25	31	40	63	50	5,5	10	25	5,7	23	-	-	•	-	-	-
30	38	48	72	58	5,5	10	25	5,7	28	-	-	-	•	-	-
32	40	48	72	58	5,5	10	25	5,7	28	-	-	-	•	-	-
38	46	58	85	70	6,6	11	30	6,8	33	-	-	-	-	•	-
40	48	58	85	70	6,6	11	30	6,8	33	-	-	-	-	•	-
48	56	70	104	86	9	15	42	9	38	-	-	-	-	-	•
50	58	70	104	86	9	15	42	9	38	-	-	-	-	-	•
60	68	85	120	100	9	15	42	9	46	-	-	-	-	-	•
63	71	85	120	100	9	15	42	9	46	-	-	-	-	-	•

Forma de pedido: CJSV + D1*L
How to order: CJSV + D1*L

CASQUILLO GUÍA PARA JAULA DE BOLAS CJSL GUIDE BUSH FOR BALL CAGE CJSL

Material: Acero Cementación / Case Hardened Steel
Dureza / Hardness: 62-63 HRC

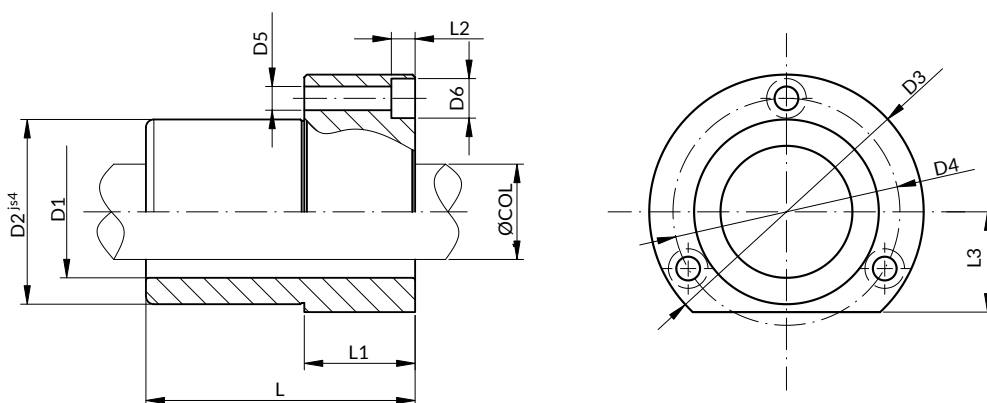

 Recomendación de montaje / Assembly recommendation
3 x DIN 912

Norma / Standard: DIN 9831 - ISO 9448-5

Ø COL	D1	D2	D3	D4	D5	D6	L1	L2	L3	L					
										52	62	72	77	102	125
19	25	32	50	40	4,5	8	15	4,6	18	•	-	-	-	-	-
20	26	32	50	40	4,5	8	15	4,6	18	•	-	-	-	-	-
24	30	40	63	50	5,5	10	25	5,7	23	-	•	-	-	-	-
25	31	40	63	50	5,5	10	25	5,7	23	-	•	-	-	-	-
30	38	48	72	58	5,5	10	25	5,7	28	-	-	•	-	-	-
32	40	48	72	58	5,5	10	25	5,7	28	-	-	•	-	-	-
38	46	58	85	70	6,6	11	30	6,8	33	-	-	-	•	-	-
40	48	58	85	70	6,6	11	30	6,8	33	-	-	-	•	-	-
48	56	70	104	86	9	15	42	9	38	-	-	-	-	•	-
50	58	70	104	86	9	15	42	9	38	-	-	-	-	•	-
60	68	85	120	100	9	15	42	9	46	-	-	-	-	•	-
63	71	85	120	100	9	15	42	9	46	-	-	-	-	•	-
80	92	105	148	125	11	18	50	11	56	-	-	-	-	-	•

Forma de pedido: CJSL + D1*L
How to order: CJSL + D1*L

JAULA DE BOLAS JB - JBB
BALL CAGE JB - JBB

JB



Material:
 Jaula / Cage: Aluminio / Aluminium
 Bolas / Balls: DIN 5401

STOCK

JBB



Material:
 Jaula / Cage: Bronce / Bronze
 Bolas / Balls: DIN 5401

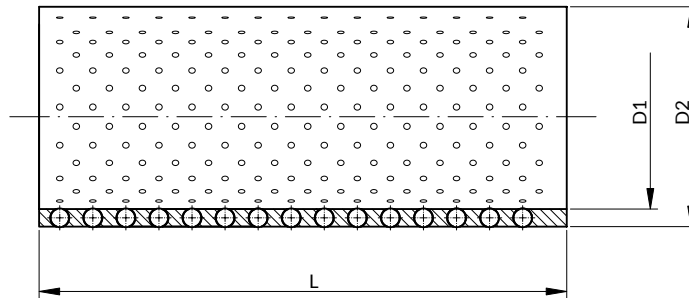

D1	D2	L																											
		30	35	38	40	43	45	50	55	60	63	65	66	70	74	75	78	80	83	85	90	95	100	110	120	140	160	180	200
10	14	-	-	•	-	•	-	-	-	-	-	-	-	-	-	-	-	-	-	-	-	-	-	-	-	-	-	-	-
12	16	•	-	•	-	•	-	•	-	-	-	-	-	-	-	-	-	-	-	-	-	-	-	-	-	-	-	-	-
14	20	•	-	-	-	•	-	-	•	-	-	-	-	-	-	-	-	-	-	-	-	-	-	-	-	-	-	-	-
15	21	•	•	-	-	-	•	-	•	-	-	-	•	-	-	•	-	-	-	-	-	-	-	-	-	-	-	-	-
16	22	•	•	-	-	-	•	-	•	-	-	-	•	-	-	•	-	-	-	-	-	-	-	-	-	-	-	-	-
18	24	-	•	-	-	-	•	•	-	•	-	•	-	-	•	-	•	-	-	-	•	-	-	-	-	-	-	-	-
19	25	-	•	-	-	-	•	•	-	•	-	•	-	-	•	-	•	-	-	-	•	-	-	-	-	-	-	-	-
24	30	-	-	-	•	-	•	•	•	-	•	-	•	-	•	-	•	-	-	-	•	-	•	-	-	-	-	-	-
24	32	-	-	-	•	-	-	-	-	-	-	•	-	•	-	-	-	-	-	-	-	-	-	-	-	-	-	-	-
25	31	-	-	-	•	-	•	•	•	•	-	•	-	•	-	•	-	•	-	-	•	-	•	-	-	-	-	-	-
25	33	-	-	-	•	-	-	-	-	-	-	•	-	•	-	-	-	-	-	-	-	-	-	-	-	-	-	-	-
30	38	-	-	-	-	-	•	•	•	-	-	•	-	•	-	•	-	-	-	•	•	•	•	•	•	•	-	-	-
32	40	-	-	-	-	-	•	•	•	•	-	•	-	•	-	•	-	-	-	•	•	•	•	•	•	•	-	-	-
40	48	-	-	-	-	-	•	•	-	•	-	•	-	•	-	•	-	-	-	•	•	•	•	•	•	•	•	-	-
42	50	-	-	-	-	-	•	•	-	•	-	•	-	•	-	•	-	-	-	•	•	•	•	•	•	•	•	-	-
50	58	-	-	-	-	-	•	•	-	•	-	•	-	•	-	•	-	-	-	•	•	-	•	•	•	•	•	-	•
52	60	-	-	-	-	-	•	•	-	•	-	•	-	•	-	•	-	-	-	•	•	-	•	•	•	•	•	-	•
60	68	-	-	-	-	-	-	-	-	-	-	-	-	•	-	-	-	-	-	-	•	•	-	•	•	•	•	-	-
63	71	-	-	-	-	-	-	-	-	-	-	-	-	•	-	-	-	-	-	-	•	•	-	•	•	•	•	-	-
60	72	-	-	-	-	-	-	-	-	-	-	-	-	-	-	-	-	-	-	-	•	-	•	•	•	•	•	-	-
63	75	-	-	-	-	-	-	-	-	-	-	-	-	-	-	-	-	-	-	-	•	-	•	•	•	•	•	-	-
80	92	-	-	-	-	-	-	-	-	-	-	-	-	-	-	-	-	-	-	-	•	-	•	•	•	•	•	-	-

Forma de pedido / How to order: JB + D1*D2*L
 JBB + D1*D2*L

JAULA DE BOLAS JBA - JBBA
BALL CAGE JBA - JBBA

JBA



Material:
 Jaula / Cage: Aluminio / Aluminium
 Bolas / Balls: DIN 5401

JBBA



Material:
 Jaula / Cage: Bronce / Bronze
 Bolas / Balls: DIN 5401

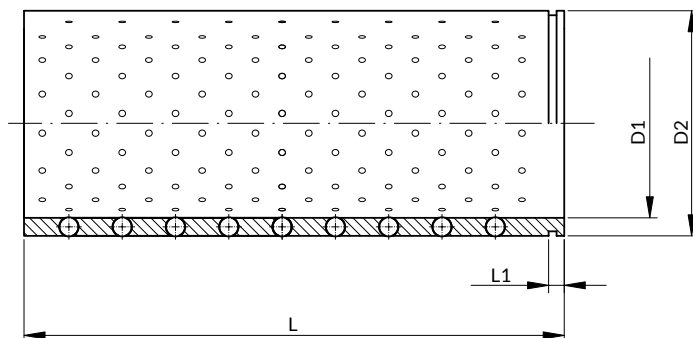

D1	D2	L1	L																												
			30	35	38	40	43	45	50	55	60	63	65	66	70	74	75	78	80	83	85	90	95	100	110	120	140	160	180	200	
10	14	2,6	-	-	•	-	•	-	-	-	-	-	-	-	-	-	-	-	-	-	-	-	-	-	-	-	-	-	-	-	-
12	16	2,6	-	-	•	-	•	-	-	-	-	-	-	-	-	-	-	-	-	-	-	-	-	-	-	-	-	-	-	-	-
14	20	3	•	-	-	-	•	-	-	•	-	-	-	•	-	-	•	-	-	-	-	-	-	-	-	-	-	-	-	-	-
15	21	3	•	•	-	-	-	•	-	•	-	-	-	•	-	-	•	-	-	-	-	-	-	-	-	-	-	-	-	-	-
16	22	3	•	•	-	-	-	•	-	•	-	-	-	•	-	-	•	-	-	-	-	-	-	-	-	-	-	-	-	-	-
18	24	3	-	•	-	-	-	•	•	-	•	-	-	•	-	-	•	-	-	•	-	-	•	-	-	-	-	-	-	-	-
19	25	3	-	•	-	-	-	•	•	-	•	-	-	•	-	-	•	-	-	•	-	-	•	-	-	-	-	-	-	-	-
24	30	3,5	-	-	-	•	-	•	•	-	•	-	-	•	-	-	•	-	-	•	-	•	-	•	-	•	-	•	-	•	-
25	31	3,5	-	-	-	•	-	•	•	-	•	-	-	•	-	-	•	-	-	•	-	•	-	•	-	•	-	•	-	•	-
30	38	4,2	-	-	-	-	-	•	•	•	-	-	•	-	-	•	-	-	•	-	•	-	•	-	•	-	•	-	•	-	•
32	40	4,2	-	-	-	-	-	•	•	•	-	-	•	-	-	•	-	-	•	-	•	-	•	-	•	-	•	-	•	-	•
40	48	4,2	-	-	-	-	-	•	•	-	•	-	-	•	-	-	•	-	-	•	-	•	-	•	-	•	-	•	-	•	-
42	50	4,2	-	-	-	-	-	•	•	-	•	-	-	•	-	-	•	-	-	•	-	•	-	•	-	•	-	•	-	•	-
50	58	4,2	-	-	-	-	-	•	•	-	•	-	-	•	-	-	•	-	-	•	-	•	-	•	-	•	-	•	-	•	-
52	60	4,2	-	-	-	-	-	•	•	-	•	-	-	•	-	-	•	-	-	•	-	•	-	•	-	•	-	•	-	•	-
60	68	5,2	-	-	-	-	-	-	-	-	-	-	-	•	-	-	•	-	-	•	-	•	-	•	-	•	-	•	-	•	-
63	71	5,2	-	-	-	-	-	-	-	-	-	-	-	•	-	-	•	-	-	•	-	•	-	•	-	•	-	•	-	•	-
60	72	5,2	-	-	-	-	-	-	-	-	-	-	-	-	-	-	-	-	-	-	-	-	-	-	-	-	-	-	-	-	-
63	75	5,2	-	-	-	-	-	-	-	-	-	-	-	-	-	-	-	-	-	-	-	-	-	-	-	-	-	-	-	-	-
80	92	6,2	-	-	-	-	-	-	-	-	-	-	-	-	-	-	-	-	-	-	-	-	-	-	-	-	-	-	-	-	-

Forma de pedido / How to order: JBA + D1*D2*L
 JBBA + D1*D2*L

JAULA DE BOLAS JBL - JBBL

BALL CAGE JBL - JBBL

JBL



Material:
Jaula / Cage: Aluminio / Aluminium
Bolas / Balls: DIN 5401

JBBL



Material:
Jaula / Cage: Bronce / Bronze
Bolas / Balls: DIN 5401

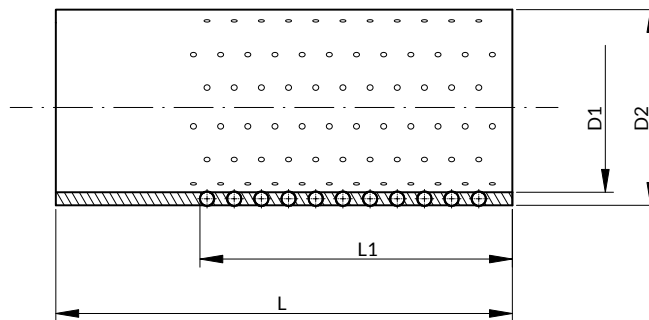

D1	D2	L1	L				
			78	94	103	122	140
15	21	60	•	-	-	-	-
16	22	60	•	-	-	-	-
18	24	72	-	•	-	-	-
19	25	72	-	•	-	-	-
24	30	78	-	-	•	-	-
25	31	78	-	-	•	-	-
30	38	90	-	-	-	•	-
32	40	90	-	-	-	•	-
40	48	100	-	-	-	-	•
42	50	100	-	-	-	-	•
50	58	100	-	-	-	-	•
52	60	100	-	-	-	-	•

Forma de pedido / How to order: JBL + D1*L
JBBL + D1*L

JAULA DE BOLAS JBS BALL CAGE JBS

Material:

Jaula / Cage: Aluminio / Aluminium

Bolas / Balls: DIN 5401

 Se suministra con sus accesorios de montaje
All accessories included

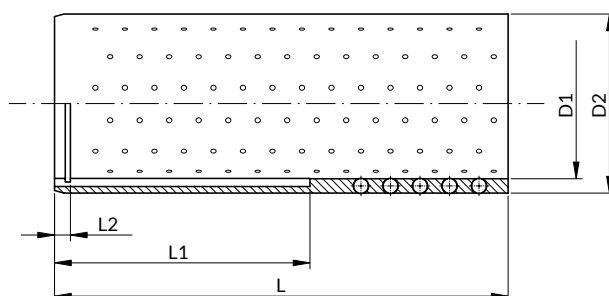

D1	D2	L	L1	L2
25	33	55	31	3,1
25	33	70	40	3,1
25	33	85	48	3,1
25	33	90	48	3,1
25	33	100	55	3,1
32	40	70	40	3,85
32	40	85	48	3,85
32	40	90	48	3,85
32	40	105	55	3,85
32	40	115	65	3,85
32	40	125	75	3,85
40	48	70	40	5,6
40	48	58	48	5,6
40	48	90	48	5,6
40	48	105	56	5,6
40	48	115	66	5,6
40	48	125	76	5,6
40	48	135	86	5,6
40	48	145	96	5,6
50	62	105	56	6,65
50	62	120	65	6,65
50	62	140	76	6,65
50	62	150	86	6,65
50	62	160	96	6,65
50	62	170	108	6,65
50	62	158	121	6,65
50	62	195	133	6,65
63	75	145	76	6,65
63	75	165	86	6,65
63	75	180	96	6,65
63	75	190	107	6,65
63	75	205	121	6,65
63	75	215	132	6,65
80	92	145	76	7,9
80	92	165	86	7,9
80	92	180	96	7,9
80	92	190	107	7,9
80	92	205	121	7,9
80	92	215	132	7,9

Forma de pedido: JBS + D1*L

How to order: JBS + D1*L

JAULA DE BOLAS JBD BALL CAGE JBD

Material:

Jaula / Cage: Aluminio / Aluminium

Bolas / Balls: DIN 5401

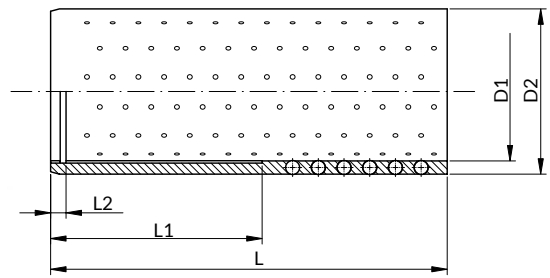

i Se suministra con sus accesorios de montaje
All accessories included

D1	D2	L	L1	L2
25	33	36	11,5	4,2
25	33	48	17,5	4,2
25	33	55	31	4,2
25	33	70	40	4,2
25	33	90	47	4,2
25	33	100	55	4,2
25	33	110	65	4,2
32	40	36	11,5	4,2
32	40	48	17,5	4,2
32	40	70	31	4,2
32	40	90	40	4,2
32	40	105	47	4,2
32	40	115	55	4,2
32	40	125	65	4,2
32	40	135	85	4,2
40	48	48	17,5	5,8
40	48	60	23,5	5,8
40	48	70	40	5,8
40	48	85	48	5,8
40	48	105	56	5,8
40	48	125	66	5,8
40	48	125	76	5,8
40	48	135	86	5,8
40	48	145	96	5,8
40	48	155	107	5,8
50	62	70	28,5	7
50	62	84	35,5	7
50	62	105	56	7
50	62	120	65	7
50	62	140	76	7
50	62	150	86	7
50	62	160	96	7
50	62	170	108	7
50	62	185	121	7
50	62	195	133	7
63	75	98	42,5	7
63	75	145	76	7
63	75	165	86	7
63	75	180	96	7
63	75	190	107	7
63	75	205	121	7
63	75	215	132	7
80	92	98	42,5	8,5
80	92	145	76	8,5
80	92	165	86	8,5
80	92	180	96	8,5
80	92	190	107	8,5
80	92	205	121	8,5
80	92	215	132	8,5

Forma de pedido: JBD + D1*L

How to order: JBD + D1*L

JAULA DE BOLAS JBI BALL CAGE JBI

Material:

Jaula / Cage: Latón / Brass

Bolas / Balls: DIN 5401

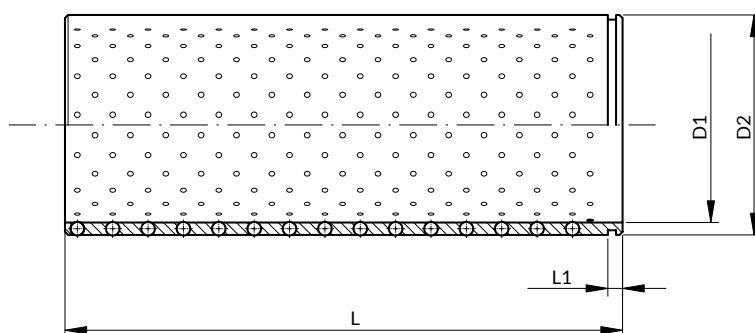

D1	D2	L1	L																
			40	45	50	56	63	71	75	80	95	105	120	140	160	180	200	240	
12	16	2,2	•	-	-	•	-	-	-	-	-	-	-	-	-	-	-	-	
18	24	2,9	-	•	-	•	-	•	-	-	-	-	-	-	-	-	-	-	
19	25	2,9	-	•	-	•	-	•	-	•	•	-	-	-	-	-	-	-	
20	26	2,9	-	•	-	•	-	•	-	•	•	-	-	-	-	-	-	-	
24	30	3,2	•	•	-	•	-	•	-	•	•	-	•	-	-	-	-	-	
25	31	3,2	•	•	-	•	-	•	-	•	•	-	•	-	-	-	-	-	
30	38	3,95	•	•	•	•	-	•	•	•	•	•	•	•	•	-	-	-	
32	40	3,95	•	•	•	•	-	•	•	•	•	•	•	•	•	-	-	-	
38	46	3,95	-	•	•	•	•	-	-	•	•	•	•	•	•	•	•	•	
40	48	3,95	-	•	•	•	•	-	-	•	•	•	•	•	•	•	•	•	
48	56	4,25	-	-	•	-	•	-	-	•	•	•	•	•	•	•	•	•	
50	58	4,25	-	-	•	-	•	-	-	•	•	•	•	•	•	•	•	•	
60	68	4,75	-	-	-	-	-	-	-	-	•	•	•	•	•	•	•	•	
63	71	4,75	-	-	-	-	-	-	-	-	•	•	•	•	•	•	•	•	
80	92	6,15	-	-	-	-	-	-	-	-	-	-	•	•	•	•	•	•	

Forma de pedido: JBI + D1*L

How to order: JBI + D1*L

JAUJA DE BOLAS SUSPENDIDA JBIS HANGING BALL CAGE JBIS

Material:

Jaula / Cage: Latón / Brass

Bolas / Balls: DIN 5401

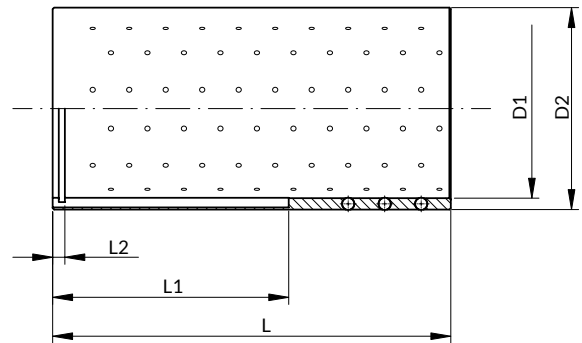

i Se suministra con sus accesorios de montaje
All accessories included

D1	D2	L	L1	L2
19	25	56	31	2,6
19	25	72	41	2,6
19	25	80	51	2,6
20	26	56	31	2,6
20	26	72	41	2,6
20	26	80	51	2,6
24	30	56	31	2,6
24	30	72	41	2,6
24	30	80	51	2,6
25	31	56	31	2,6
25	31	72	41	2,6
25	31	80	51	2,6
30	38	70	41	2,6
30	38	80	51	2,6
30	38	95	61	2,6
30	38	105	61	2,6
32	40	70	41	2,6
32	40	80	51	2,6
32	40	95	61	2,6
32	40	105	61	2,6
38	46	80	51	3,5
38	46	95	61	3,5
38	46	105	61	3,5
38	46	120	73	3,5
40	48	80	51	3,5
40	48	95	61	3,5
40	48	105	61	3,5
40	48	120	73	3,5
48	56	80	51	4,3
48	56	95	61	4,3
48	56	105	61	4,3
48	56	120	73	4,3
50	58	80	51	4,3
50	58	95	61	4,3
50	58	105	61	4,3
50	58	120	73	4,3
60	68	95	61	4,3
60	68	120	73	4,3
60	68	140	83	4,3
63	71	95	61	4,3
63	71	120	73	4,3
63	71	140	83	4,3
80	92	95	61	5
80	92	120	73	5
80	92	140	83	5

Forma de pedido: JBIS + D1*L

How to order: JBIS + D1*L

JAULA DE RODILLOS JBR ROLLER CAGE JBR

Material:

Jaula / Cage: Aluminio / Aluminium

Rodillos / Rollers: DIN 5402

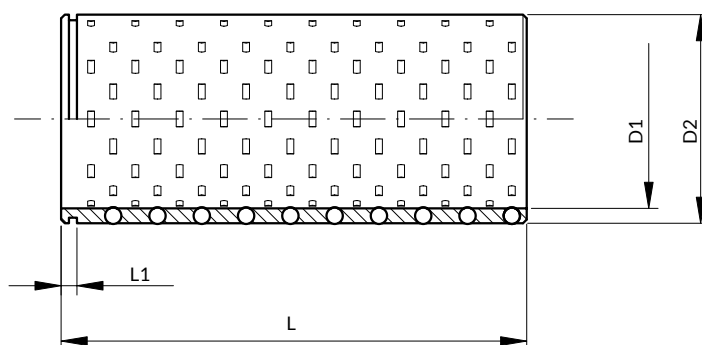

D1	D2	L1	L								
			45	55	65	75	85	95	105	115	125
19	25	1,6	•	•	•	•	-	-	-	-	-
20	26	1,6	•	•	•	•	-	-	-	-	-
24	30	1,6	•	•	•	•	•	-	-	-	-
25	31	1,6	•	•	•	•	•	-	-	-	-
30	38	2,1	•	•	•	•	•	•	•	-	-
32	40	2,1	•	•	•	•	•	•	•	-	-
38	46	2,1	-	•	•	•	•	•	•	•	•
40	48	2,1	-	•	•	•	•	•	•	•	•
48	56	2,1	-	-	•	•	•	•	•	•	•
50	58	2,1	-	-	•	•	•	•	•	•	•

Forma de pedido: JBR + D1*L

How to order: JBR + D1*L

MUELLE PARA JAULA DE BOLAS MJB SPRING FOR BALL CAGE MJB

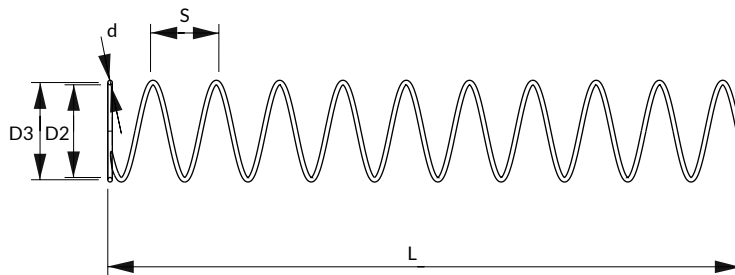
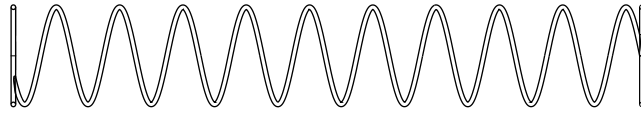

\varnothing COL / PILL \varnothing	D2	D3	S	d	L	Constante elástica L / Spring constant L
19/20	20,5	22,5	14	1	40-140	10
24/25	25,5	27,9	14	1,2	40-160	10
30/32	32,5	35,7	16	1,6	50-230	10
38	38,5	42,5	18	2	60-230	10
40	40,5	45,1	20	2,3	60-230	10
42	42,5	47,1	20	2,4	60-230	10
48/50	50,5	55,7	20	2,6	70-230	10
52	52,5	57,7	20	2,6	70-230	10
60	60,5	66,9	20	3,2	80-250	10
63	63,5	69,9	20	3,2	80-250	10

Forma de pedido: MJB + D2*L
How to order: MJB + D2*L

CASQUILLO DE BOLAS CON VALONA CBOV BALL GUIDE BUSH WITH COLLAR CBOV

Material:

Casquillo / Bush: Acero / Steel

Jaula / Cage: Bronce / Bronze

Bolas / Balls: DIN 5401

Dureza casquillo / Bush hardness: 60 - 62 HRC

STOCK

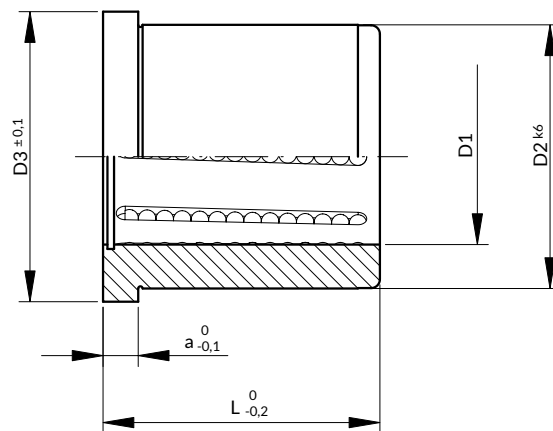

D1	L	D2	D3	a	Ø bola / Ø ball	nº líneas / lines
20	35	32	36	6	3	6
25	35	40	45	6	3	8
25	45	40	45	6	3	8
25	55	40	45	6	3	8
32	45	50	56	8	4	8
32	63	50	56	8	4	8
40	45	60	66	8	4	8
40	63	60	66	8	4	8

Forma de pedido: CBOV + D1*L

How to order: CBOV + D1*L

CASQUILLO DE BOLAS CON VALONA CBOM BALL GUIDE BUSH WITH COLLAR CBOM

Material:

Casquillo / Bush: Acero / Steel

Jaula / Cage: Bronce / Bronze

Bolas / Balls: DIN 5401

Dureza casquillo / Bush hardness: 60 - 62 HRC

STOCK

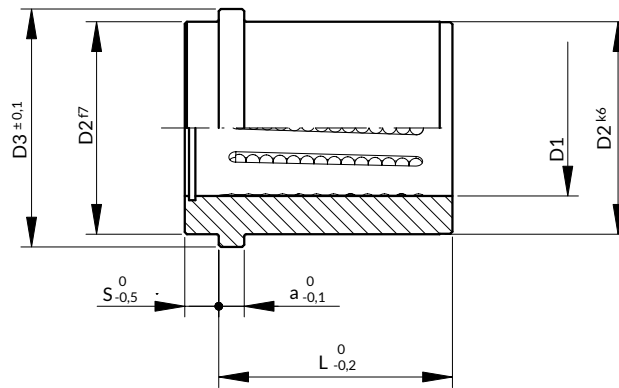

D1	L	D2	D3	a	s	Ø bola / Ø ball	nº líneas / lines
12	22	24	28	6	8	3	5
16	22	28	32	6	8	3	6
16	26	28	32	6	9	3	6
20	26	32	36	6	9	3	6
20	35	32	36	6	9	3	6
25	26	40	45	6	9	3	8
25	35	40	45	6	10	3	8
25	45	40	45	6	10	3	8
25	55	40	45	6	10	3	8
32	45	50	56	8	12	4	8
32	63	50	56	8	12	4	8
40	45	60	66	8	12	4	8
40	63	60	66	8	12	4	8
50	55	70	76	10	25	4	8
60	55	85	91	10	25	4	8

Forma de pedido: CBOM + D1*L

How to order: CBOM + D1*L

CASQUILLO DE BOLAS LISO CBOL BALL GUIDE BUSH CBOL

Material:

Casquillo / Bush: Acero / Steel

Jaula / Cage: Bronce / Bronze

Bolas / Balls: DIN 5401

Dureza casquillo / Bush hardness: 60 - 62 HRC

STOCK

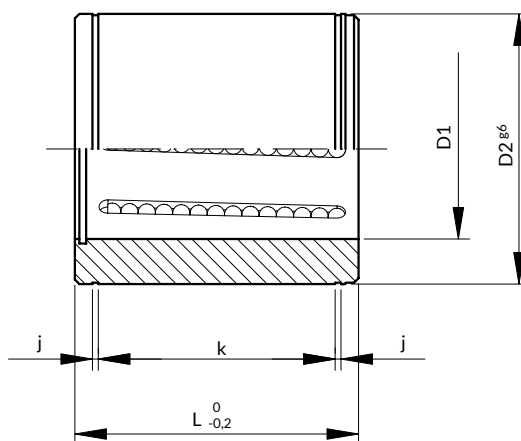

D1	L	D2	k	j	Ø bola / Ø ball	nº líneas / lines
12	30	24	20	1,3	3	5
16	30	28	19	1,6	3	6
16	35	28	24	1,6	3	6
20	35	32	24	1,6	3	6
20	45	32	34	1,6	3	6
25	35	40	23	1,8	3	8
25	45	40	33	1,8	3	8
25	55	40	43	1,8	3	8
32	45	50	33	2,1	4	8
32	63	50	51	2,1	4	8
40	45	60	33	2,1	4	8
40	63	60	51	2,1	4	8

Forma de pedido: CBOL + D1*L

How to order: CBOL + D1*L

CASQUILLO GUÍA CBGC GUIDE BUSH CBGC

Material: Bronce + grafito / Bronze + graphite
Dureza / Hardness: HB > 190

STOCK

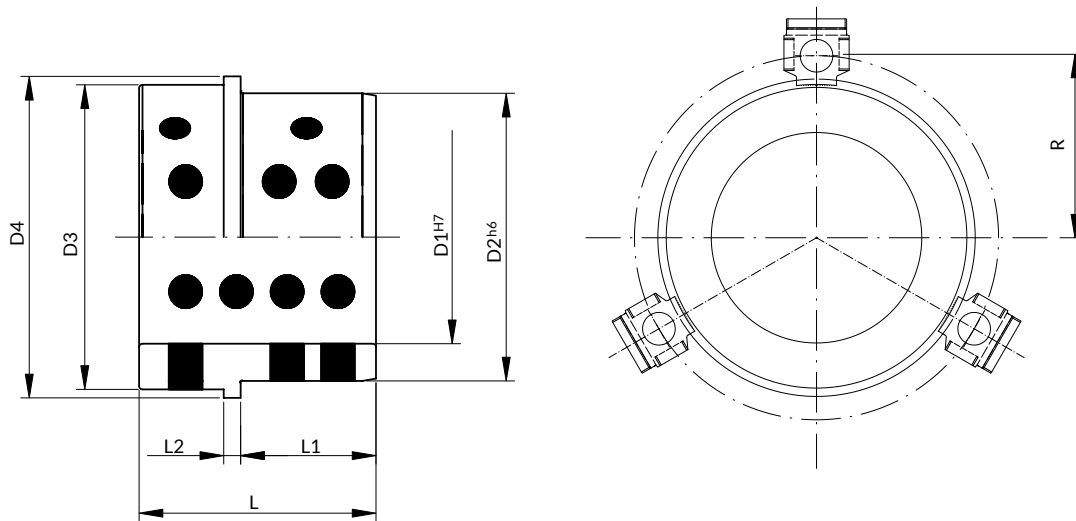

i Recomendación de montaje / Assembly recommendation
D1 ≤ 63 = 3 x BRE 6 + TCI M6x15
D1 = 80 = 3 x BRE 8 / BRE A 8 + TCI M8x20

D1	D2	D3	D4	L1	L2	R	L							
							31	33	40	45	48	57	70	100
15	28	30	34	15	5	21,5	•	-	-	-	-	-	-	-
16	28	30	34	15	5	21,5	•	-	-	-	-	-	-	-
18	32	34	38	17	5	23,5	-	•	-	-	-	-	-	-
19	32	34	38	17	5	23,5	-	•	-	-	-	-	-	-
24	40	43	48	22	5	29	-	-	•	-	-	-	-	-
25	40	43	48	22	5	29	-	-	•	-	-	-	-	-
30	48	53	58	27	5	34	-	-	-	•	-	-	-	-
32	48	53	58	27	5	34	-	-	-	•	-	-	-	-
40	58	66	72	30	5	41	-	-	-	-	•	-	-	-
42	58	66	72	30	5	41	-	-	-	-	•	-	-	-
50	68	77	82	35	5	46	-	-	-	-	-	•	-	-
52	68	77	82	35	5	46	-	-	-	-	-	•	-	-
60	85	90	95	40	5	52,5	-	-	-	-	-	-	•	-
63	85	90	95	40	5	52,5	-	-	-	-	-	-	•	-
80	100	112	120	55	6,5	65	-	-	-	-	-	-	-	•

Forma de pedido: CBGC + D1
How to order: CBGC + D1

CASQUILLO GUÍA CBGV GUIDE BUSH CBGV

Material: Bronce + grafito / Bronze + graphite
Dureza / Hardness: HB > 190

STOCK

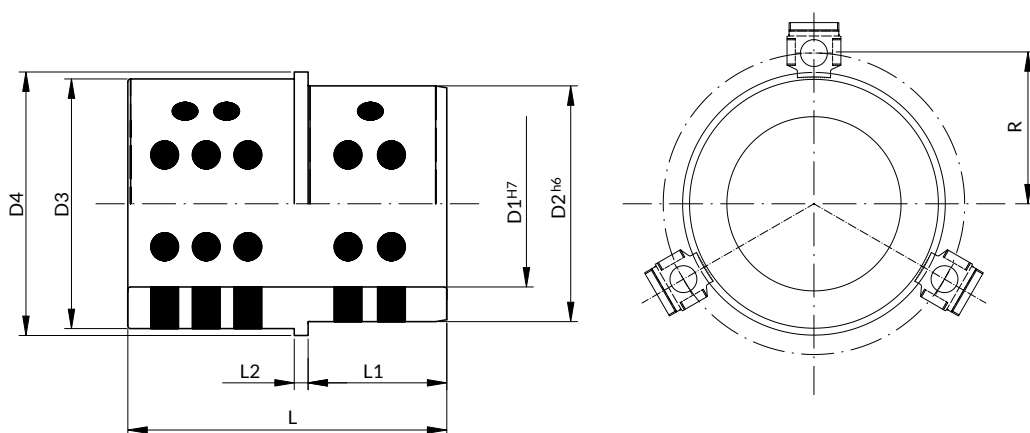

i Recomendación de montaje / Assembly recommendation
D1≤63 = 3 x BRE 6 + TCI M6x15
D1=80 = 3 x BRE 8 / BREA 8 + TCI M8x20

D1	D2	D3	D4	L1	L2	R	L								
							50	60	65	75	80	85	100	115	125
15	28	30	34	20	5	21,5	•	-	-	-	-	-	-	-	-
16	28	30	34	20	5	21,5	•	-	-	-	-	-	-	-	-
18	32	34	38	25	5	23,5	-	•	-	-	-	-	-	-	-
19	32	34	38	25	5	23,5	-	•	-	-	-	-	-	-	-
24	40	43	48	30	5	29	-	•	-	•	-	-	-	-	-
25	40	43	48	30	5	29	-	•	-	•	-	-	-	-	-
30	48	53	58	30	5	34	-	•	-	-	•	-	-	-	-
32	48	53	58	30	5	34	-	•	-	-	•	-	-	-	-
40	58	66	72	35	5	41	-	-	•	-	-	•	-	-	-
42	58	66	72	35	5	41	-	-	•	-	-	•	-	-	-
50	68	77	82	45	5	46	-	-	-	•	-	-	•	-	-
52	68	77	82	45	5	46	-	-	-	•	-	-	•	-	-
60	85	90	95	50	5	52,5	-	-	-	-	-	-	-	•	-
63	85	90	95	50	5	52,5	-	-	-	-	-	-	-	•	-
80	100	112	120	55	6,5	65	-	-	-	-	-	-	-	-	•

Forma de pedido: CBGV + D1*L
How to order: CBGV + D1*L

CASQUILLO GUÍA CBGL GUIDE BUSH CBGL

Material: Bronce + grafito / Bronze + graphite
Dureza / Hardness: HB > 190

STOCK

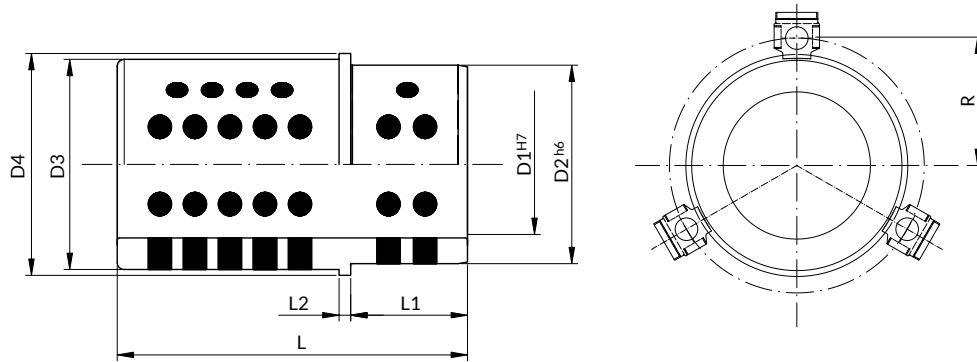

i Recomendación de montaje / Assembly recommendation
D1≤63 = 3 x BRE 6 + TCI M6x15
D1=80 = 3 x BRE 8 / BRE A 8 + TCI M8x20

D1	D2	D3	D4	L1	L2	R	L								
							105	110	115	125	130	135	145	150	180
18	32	34	38	25	5	23,5	•	-	-	•	-	-	-	-	-
19	32	34	38	25	5	23,5	•	-	-	•	-	-	-	-	-
24	40	43	48	30	5	29	-	•	-	-	•	-	-	-	-
25	40	43	48	30	5	29	-	•	-	-	•	-	-	-	-
30	48	53	58	30	5	34	-	•	-	-	•	-	-	-	-
32	48	53	58	30	5	34	-	•	-	-	•	-	-	-	-
40	58	66	72	35	5	41	-	-	•	-	-	•	-	-	-
42	58	66	72	35	5	41	-	-	•	-	-	•	-	-	-
50	68	77	82	45	5	46	-	-	-	•	-	-	•	-	-
52	68	77	82	45	5	46	-	-	-	•	-	-	•	-	-
60	85	90	95	50	5	52,5	-	-	-	-	•	-	-	•	-
63	85	90	95	50	5	52,5	-	-	-	-	•	-	-	•	-
80	100	112	120	55	6,5	65	-	-	-	-	-	-	-	-	•

Forma de pedido: CBGL + D1*L
How to order: CBGL + D1*L

CASQUILLO GUÍA BGW GUIDE BUSH BGW

Material: Bronce + grafito / Bronze + graphite
Dureza / Hardness: HB > 190

STOCK

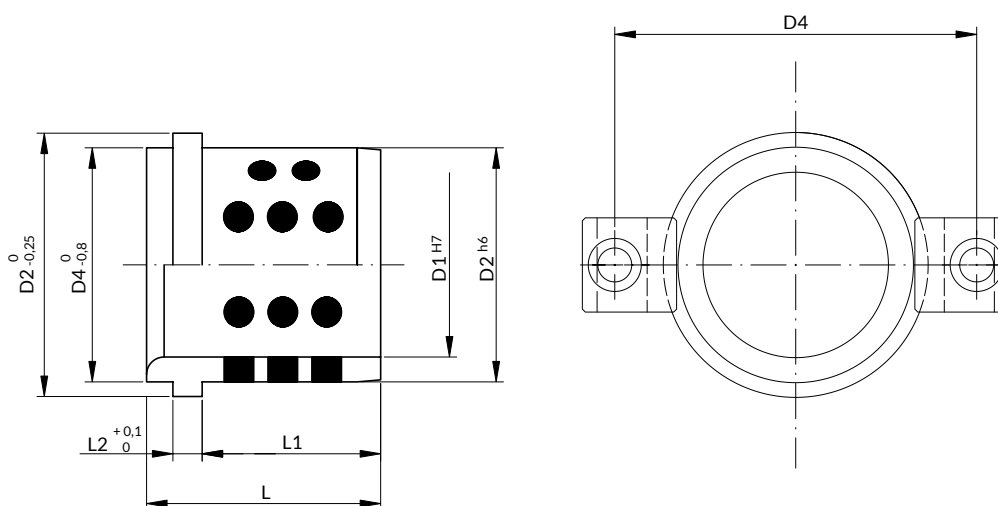

i Recomendación de montaje / Assembly recommendation
D1 ≤ 50 : 2 x BRW20 + TCC M6X16
D1 > 50 : 2 x BRW32 + TCC M10X20

Norma / Standard: DIN 9834

D1	D2	D3	D4	L1	L2	L								
						40	50	63	71	80	100	125	160	200
25	32	40	58	30	6,3	•	-	-	-	-	-	-	-	-
32	40	50	66	38	6,3	-	•	-	-	-	-	-	-	-
40	50	63	79	48	6,3	-	-	•	-	-	-	-	-	-
50	63	71	89	54	6,3	-	-	-	•	-	-	-	-	-
63	80	90	123	61	10	-	-	-	-	•	-	-	-	-
80	100	112	143	78	10	-	-	-	-	-	•	-	-	-
100	125	140	168	104	10	-	-	-	-	-	-	•	-	-
125	160	180	203	130	10	-	-	-	-	-	-	-	•	-
160	200	220	243	168	10	-	-	-	-	-	-	-	-	•

Forma de pedido: BGW + D1*L
How to order: BGW + D1*L

CASQUILLO GUÍA BGP GUIDE BUSH BGP

Material: Bronce + grafito / Bronze + graphite
Dureza / Hardness: HB > 190

STOCK

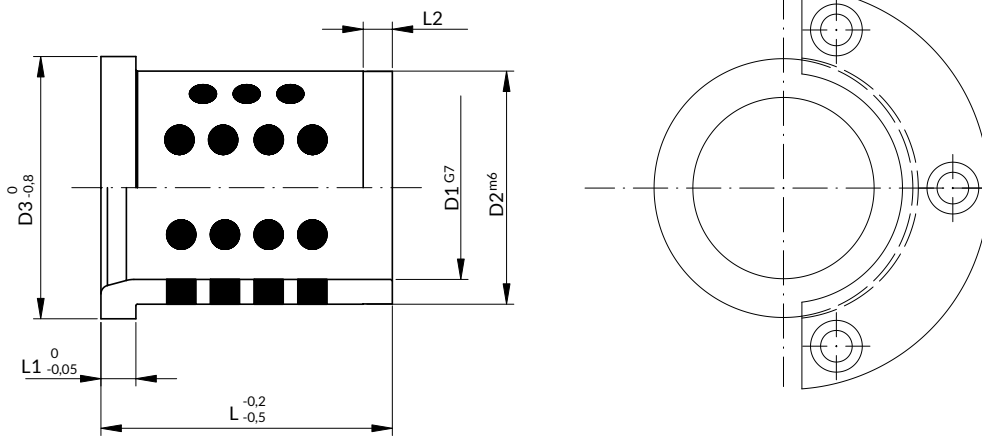

i Recomendación de montaje con brida BRCA, BRCC o BRM
Assembly recommendation with BRCA, BRCC or BRM clamp

Norma / Standard: AFNOR

D1	D2	D3	L1	L2	L								
					32	40	50	63	80	100	125	160	
20	28	32	4	4	•	-	-	-	-	-	-	-	-
25	35	40	5	5	-	•	-	-	-	-	-	-	-
32	44	50	6	8	-	-	•	-	-	-	-	-	-
40	52	60	8	8	-	-	-	•	-	-	-	-	-
50	63	71	10	8	-	-	-	-	•	-	-	-	-
63	80	90	12	10	-	-	-	-	-	•	-	-	-
80	100	112	16	10	-	-	-	-	-	-	•	-	-
100	125	140	20	10	-	-	-	-	-	-	-	-	•

Forma de pedido: BGP + D1*L

How to order: BGP + D1*L

CASQUILLO GUÍA BGN GUIDE BUSH BGN

Material: Bronce + grafito / Bronze + graphite
Dureza / Hardness: HB > 190

STOCK

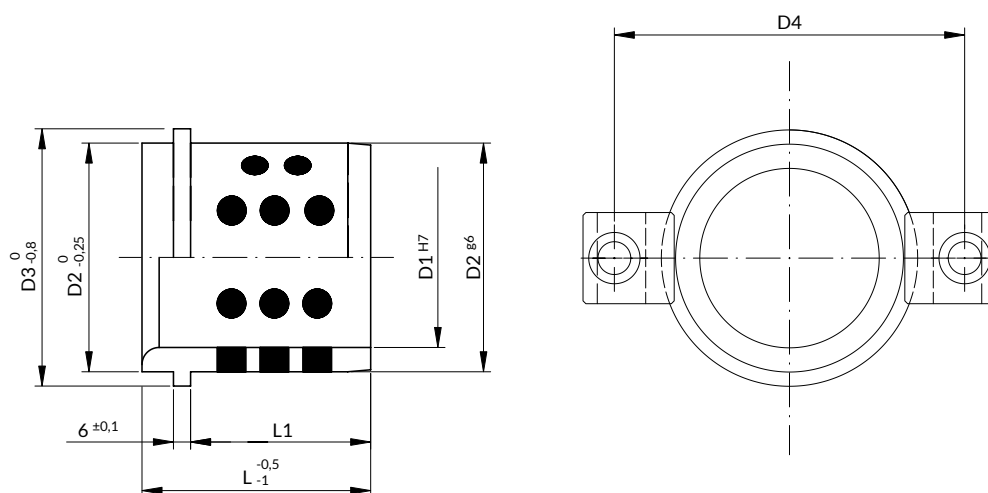

i Recomendación de montaje / Assembly recommendation
2x BRN32 + TCC M10X20

D1	D2	D3	D4	L1	L							
					40	50	63	71	80	100	125	160
25	32	40	75	30	•	-	-	-	-	-	-	-
32	40	50	83	40	-	•	-	-	-	-	-	-
40	50	63	93	50	-	-	•	-	-	-	-	-
50	63	71	106	56	-	-	-	•	-	-	-	-
63	80	90	123	63	-	-	-	-	•	-	-	-
80	100	112	143	80	-	-	-	-	-	•	-	-
100	125	140	168	106	-	-	-	-	-	-	•	-
125	160	180	203	132	-	-	-	-	-	-	-	•

Forma de pedido: BGN + D1*L
How to order: BGN + D1*L

CASQUILLO GUÍA BGO GUIDE BUSH BGO

Material: Bronce + grafito / Bronze + graphite
Dureza / Hardness: HB > 190

STOCK

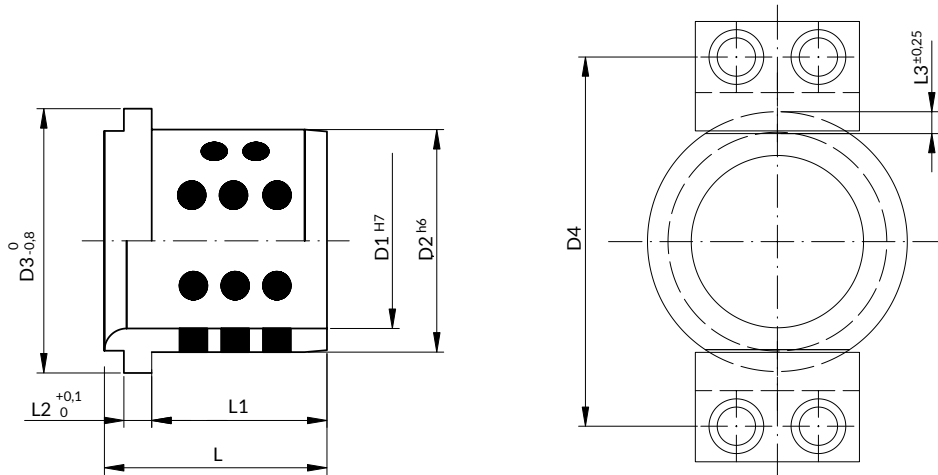

i Recomendación de montaje con brida BRO
Assembly recommendation with BRO clamp

D1	D2	D3	D4	L1	L2	L3	L						
							32	50	63	72	80	100	125
25	32	40	60	22	5	3,5	•	-	-	-	-	-	-
32	40	50	69	40	5	4	-	•	-	-	-	-	-
40	50	63	80	50	8	5	-	-	•	-	-	-	-
50	63	75	96	58	8	6	-	-	-	•	-	-	-
63	80	95	117	63	10	8	-	-	-	-	•	-	-
80	100	120	138	80	10	10	-	-	-	-	-	•	-
100	125	150	180	100	16	13	-	-	-	-	-	-	•

Forma de pedido: BGO + D1*L
How to order: BGO + D1*L

CASQUILLO GUÍA BGT GUIDE BUSH BGT

Material: Bronce + grafito / Bronze + graphite
Dureza / Hardness: HB > 190

STOCK

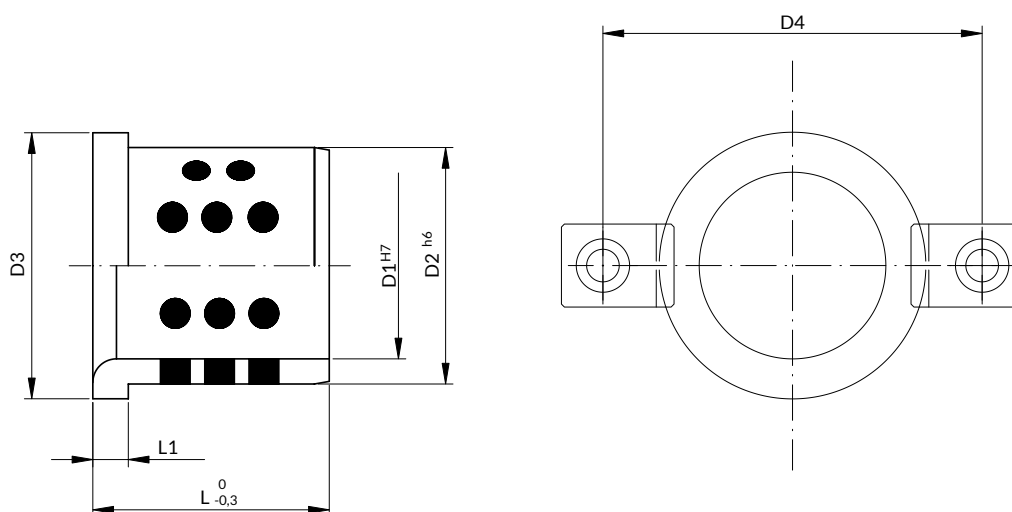

i Recomendación de montaje / Assembly recommendation
D1 ≤ 42: 2 x BRT31 + TCC M8X20
D1 > 42: 2 x BRT38 + TCC M10X20

D1	D2	D3	D4	L1	L						
					35	55	70	75	80	100	125
20	28	36	70	8	•	-	-	-	-	-	-
32	40	50	84	8	-	•	-	-	-	-	-
40	50	60	94	8	-	-	•	-	-	-	-
42	50	60	94	8	-	-	•	-	-	-	-
50	63	75	113	12	-	-	-	•	-	-	-
52	63	75	113	12	-	-	-	•	-	-	-
63	80	90	128	12	-	-	-	-	•	-	-
80	100	110	148	12	-	-	-	-	-	•	-
100	125	135	173	12	-	-	-	-	-	-	•

Forma de pedido: BGT + D1*L
How to order: BGT + D1*L

CASQUILLO GUÍA BGF GUIDE BUSH BGF

Material: Bronce + grafito / Bronze + graphite
Dureza / Hardness: HB > 190

STOCK

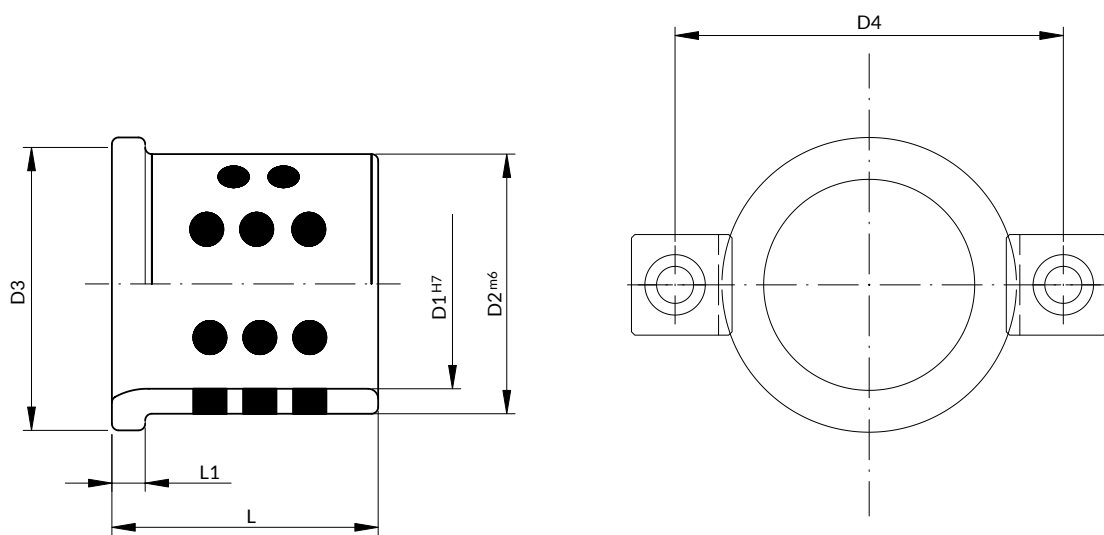

i Recomendación de montaje con brida BRM
Assembly recommendation with BRM clamp

$D1 \geq 30: 2 \times \text{BRM50} + \text{TCC M8X20}$

D1	D2	D3	D4	L1	L1				
					40	50	70	80	100
25	35	45	51	7	•	-	-	-	-
30	40	50	56	10	-	•	-	-	-
40	55	65	75,5	10	-	-	•	-	-
50	65	75	88	10	-	-	-	•	-
63	78	88	103,5	10	-	-	-	•	-
80	100	110	130,5	10	-	-	-	-	•
100	120	130	153	10	-	-	-	-	•

Forma de pedido: BGF + D1
How to order: BGF + D1

CASQUILLO GUÍA CBP GUIDE BUSH CBP

Material: Bronce / Bronze
Dureza / Hardness: HB > 190

STOCK

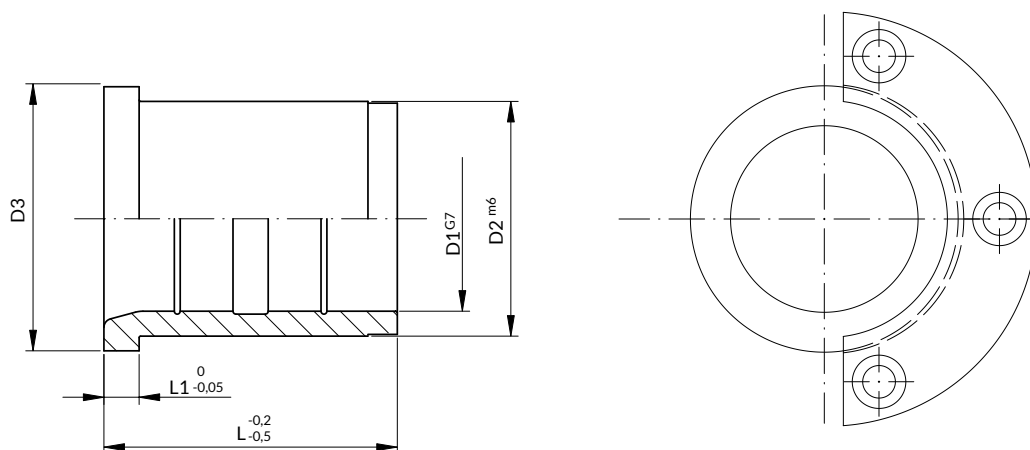

i Recomendación de montaje con brida **BRCA, BRCC** o **BRM**
Assembly recommendation with **BRCA, BRCC** or **BRM** clamp

D1	D2	D3	D4	L1	L								
					32	40	50	63	85	100	125	160	
20	28	32	22	4	•	-	-	-	-	-	-	-	-
25	35	40	27	5	-	•	-	-	-	-	-	-	-
32	44	50	34	6	-	-	•	-	-	-	-	-	-
40	52	60	42	8	-	-	-	•	-	-	-	-	-
50	63	71	52	10	-	-	-	-	•	-	-	-	-
63	80	90	65	12	-	-	-	-	-	•	-	-	-
80	100	112	82	16	-	-	-	-	-	-	•	-	-
100	125	140	102	20	-	-	-	-	-	-	-	-	•

Forma de pedido: CBP + D1*L
How to order: CBP + D1*L

CASQUILLO GUÍA BGA GUIDE BUSH BGA

Material: Bronce + grafito / Bronze + graphite
Dureza / Hardness: HB > 190

STOCK

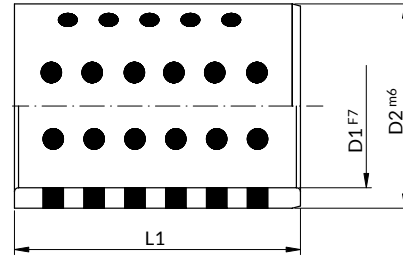

D1	D2	L1																				
		8	10	12	15	16	20	25	30	35	40	45	50	60	70	80	100	120	130	140	150	
8	12	•	•	•	•	-	-	-	-	-	-	-	-	-	-	-	-	-	-	-	-	-
10	14	•	•	•	•	-	•	-	-	-	-	-	-	-	-	-	-	-	-	-	-	-
12	18	-	•	•	•	•	•	•	•	-	-	-	-	-	-	-	-	-	-	-	-	-
13	19	-	•	-	•	-	•	-	-	-	-	-	-	-	-	-	-	-	-	-	-	-
14	20	-	•	•	•	-	•	•	•	-	-	-	-	-	-	-	-	-	-	-	-	-
15	21	-	•	•	•	•	•	•	•	-	-	-	-	-	-	-	-	-	-	-	-	-
16	22	-	•	•	-	•	•	•	•	•	-	-	-	-	-	-	-	-	-	-	-	-
18	24	-	-	-	•	•	•	•	•	-	-	-	-	-	-	-	-	-	-	-	-	-
20	28	-	-	-	•	•	•	•	•	•	•	-	-	-	-	-	-	-	-	-	-	-
20	30	-	-	-	-	•	•	•	•	•	•	-	-	-	-	-	-	-	-	-	-	-
25	33	-	-	-	-	•	•	•	•	•	•	•	•	-	-	-	-	-	-	-	-	-
25	35	-	-	-	-	•	•	•	•	•	•	•	•	-	-	-	-	-	-	-	-	-
30	38	-	-	-	-	-	•	•	•	•	•	•	•	-	-	-	-	-	-	-	-	-
30	40	-	-	-	-	-	•	•	•	•	•	•	•	-	-	-	-	-	-	-	-	-
31,5	40	-	-	-	-	-	-	-	•	-	-	-	-	-	-	-	-	-	-	-	-	-
35	44	-	-	-	-	-	-	-	•	•	•	•	•	-	-	-	-	-	-	-	-	-
35	45	-	-	-	-	-	•	•	•	•	•	•	•	-	-	-	-	-	-	-	-	-
40	50	-	-	-	-	-	•	•	•	•	•	•	•	•	-	-	-	-	-	-	-	-
40	55	-	-	-	-	-	-	•	•	•	•	•	•	•	-	-	-	-	-	-	-	-
45	55	-	-	-	-	-	-	-	•	•	•	•	•	•	-	-	-	-	-	-	-	-
45	56	-	-	-	-	-	-	-	•	•	•	•	•	•	-	-	-	-	-	-	-	-
45	60	-	-	-	-	-	-	-	•	•	•	•	•	•	•	-	-	-	-	-	-	-
50	60	-	-	-	-	-	-	-	•	•	•	•	•	•	•	-	-	-	-	-	-	-
50	62	-	-	-	-	-	-	-	•	•	•	•	•	•	•	-	-	-	-	-	-	-
50	65	-	-	-	-	-	-	-	•	•	•	•	•	•	•	-	-	-	-	-	-	-
55	70	-	-	-	-	-	-	-	-	•	•	•	•	•	•	-	-	-	-	-	-	-
60	74	-	-	-	-	-	-	-	•	•	•	•	•	•	•	-	-	-	-	-	-	-
60	75	-	-	-	-	-	-	-	•	•	•	•	•	•	•	•	-	-	-	-	-	-
63	75	-	-	-	-	-	-	-	-	-	-	-	-	•	•	•	-	-	-	-	-	-
65	80	-	-	-	-	-	-	-	-	-	-	-	-	•	•	•	•	-	-	-	-	-
70	85	-	-	-	-	-	-	-	•	•	•	•	•	•	•	•	-	-	-	-	-	-
70	90	-	-	-	-	-	-	-	-	•	•	•	•	•	•	•	-	-	-	-	-	-
75	90	-	-	-	-	-	-	-	-	-	-	-	-	•	•	•	•	-	-	-	-	-
75	95	-	-	-	-	-	-	-	-	-	-	-	-	•	•	•	•	-	-	-	-	-
80	96	-	-	-	-	-	-	-	-	•	•	•	•	•	•	•	•	-	-	-	-	-
80	100	-	-	-	-	-	-	-	-	•	•	•	•	•	•	•	•	-	-	-	•	-
90	110	-	-	-	-	-	-	-	-	-	-	-	-	•	-	•	•	-	-	-	-	-
100	120	-	-	-	-	-	-	-	-	-	-	-	-	•	•	•	•	-	-	-	•	-
110	130	-	-	-	-	-	-	-	-	-	-	-	-	-	•	•	•	•	-	-	-	-
120	140	-	-	-	-	-	-	-	-	-	-	-	-	-	-	•	•	•	-	-	•	-
125	145	-	-	-	-	-	-	-	-	-	-	-	-	-	-	•	•	-	-	-	-	-
130	150	-	-	-	-	-	-	-	-	-	-	-	-	-	-	•	-	•	-	-	-	-
140	160	-	-	-	-	-	-	-	-	-	-	-	-	-	-	•	-	-	-	-	•	-
150	170	-	-	-	-	-	-	-	-	-	-	-	-	-	-	•	-	-	-	-	-	•
160	180	-	-	-	-	-	-	-	-	-	-	-	-	-	-	•	-	-	-	-	-	•

Forma de pedido: BGA + D1*D2*L1
How to order: BGA + D1*D2*L1

CASQUILLO GUÍA BGB GUIDE BUSH BGB

Material: Bronce + grafito / Bronze + graphite
Dureza / Hardness: HB \geq 190

STOCK

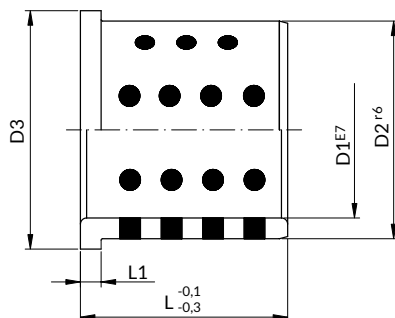

D1	D2	D3	L1	L												
				10	15	20	25	30	35	40	50	60	67,5	80	100	
10	14	22	2	•	•	•	-	-	-	-	-	-	-	-	-	-
12	18	25	3	•	•	•	-	-	-	-	-	-	-	-	-	-
13	19	26	3	•	•	•	-	-	-	-	-	-	-	-	-	-
14	20	27	3	-	•	•	-	-	-	-	-	-	-	-	-	-
15	21	28	3	•	•	•	•	•	-	-	-	-	-	-	-	-
16	22	29	3	-	•	•	•	•	-	-	-	-	-	-	-	-
20	30	40	5	-	•	•	•	•	-	•	-	-	-	-	-	-
25	35	45	5	-	•	•	•	•	-	•	-	-	-	-	-	-
30	40	50	5	-	-	•	•	•	•	•	•	-	-	-	-	-
31,5	40	50	5	-	-	•	-	•	•	-	-	-	-	-	-	-
35	45	60	5	-	-	•	-	•	-	•	•	-	-	-	-	-
40	50	65	5	-	-	•	-	•	-	•	•	-	-	-	-	-
45	55	70	5	-	-	-	-	•	-	•	•	•	-	-	-	-
50	60	75	5	-	-	-	-	•	-	•	•	•	-	-	-	-
55	65	80	5	-	-	-	-	-	-	•	-	•	-	-	-	-
60	75	90	7,5	-	-	-	-	-	-	•	•	•	-	•	-	-
63	75	85	7,5	-	-	-	-	-	-	-	-	-	•	-	-	-
70	85	105	7,5	-	-	-	-	-	-	-	•	-	-	-	•	-
75	90	110	7,5	-	-	-	-	-	-	-	-	•	-	-	-	-
80	100	120	10	-	-	-	-	-	-	-	-	•	-	-	•	•
90	110	130	10	-	-	-	-	-	-	-	-	•	-	-	•	-
100	120	150	10	-	-	-	-	-	-	-	-	-	-	-	•	•
120	140	170	10	-	-	-	-	-	-	-	-	-	-	-	•	•

Forma de pedido: BGB + D1*D2*L

How to order: BGB + D1*D2*L

ARANDELA AUTOLUBRICADA ABG OILLESS WASHER ABG

Material: Bronce + grafito / Bronze + graphite
Dureza / Hardness: HB \geq 210

STOCK

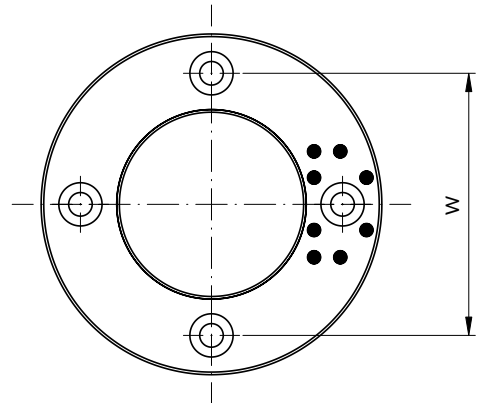
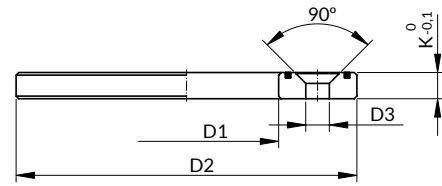

D1	D2	D3	K	W	M	Agujeros de tornillo Bolt Holes
10,2	30	3,5	3	20	M3	2
12,2	40	3,5	3	28	M3	2
13,2	40	3,5	3	28	M3	2
14,2	40	3,5	3	28	M3	2
15,2	50	3,5	3	35	M3	2
16,2	50	3,5	3	35	M3	2
18,2	50	3,5	3	35	M3	2
20,2	50	6	5	35	M5	2
25,2	55	6	5	40	M5	2
30,2	60	6	5	45	M5	2
35,2	70	6	5	50	M5	2
40,2	80	7	7	60	M6	2
45,3	90	7	7	67,5	M6	2
50,3	100	7	8	75	M6	4
55,3	110	7	8	85	M6	4
60,3	120	9	8	90	M8	4
65,3	125	9	8	95	M8	4
70,3	130	9	10	100	M8	4
75,3	140	9	10	110	M8	4
80,3	150	9	10	120	M8	4
90,3	170	11	10	140	M10	4
100,5	190	11	10	160	M10	4
120,5	200	11	10	175	M10	4

Forma de pedido: ABG + D1 (nominal)
How to order: ABG + D1 (nominal)

CASQUILLO AUTOLUBRICADO A SELF-LUBRICATING BUSH A

Material: Bronce sinterizado / Sintered bronze
Dureza / Hardness: HB = 35

STOCK

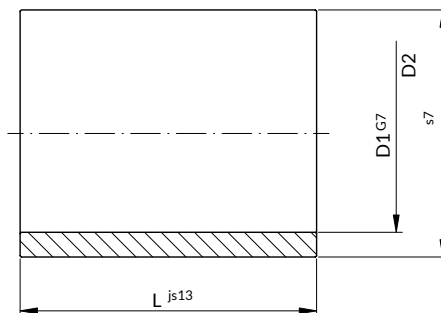

Norma / Standard: ISO 2795

D1	D2	L																			
		2	3	4	5	6	8	10	12	14	15	16	18	20	22	25	28	30	32	35	36
2	5	•	•	-	-	-	-	-	-	-	-	-	-	-	-	-	-	-	-	-	-
3	6	-	-	•	•	•	-	•	-	-	-	-	-	-	-	-	-	-	-	-	-
4	6	-	-	-	•	-	•	•	-	-	-	-	-	-	-	-	-	-	-	-	-
4	7	-	-	•	-	-	•	-	•	-	-	-	-	-	-	-	-	-	-	-	-
4	8	-	-	•	•	•	-	•	-	-	-	-	-	-	-	-	-	-	-	-	-
5	8	-	-	-	•	-	•	•	-	•	•	-	-	-	-	-	-	-	-	-	-
5	9	-	-	-	•	•	-	•	-	-	-	-	-	-	-	-	-	-	-	-	-
5	10	-	-	-	•	•	•	•	-	•	-	-	-	-	-	-	-	-	-	-	-
6	9	-	-	•	-	•	-	•	-	•	•	-	-	-	-	-	-	-	-	-	-
6	10	-	-	•	•	•	-	•	-	•	•	-	-	-	-	-	-	-	-	-	-
6	12	-	-	-	•	•	•	•	-	•	•	-	-	-	-	-	-	-	-	-	-
7	10	-	-	-	•	-	•	•	-	-	-	-	-	-	-	-	-	-	-	-	-
8	10	-	-	-	-	•	-	•	-	•	-	-	-	-	-	-	-	-	-	-	-
8	11	-	-	-	-	•	•	-	•	-	-	•	-	-	-	-	-	-	-	-	-
8	12	-	-	-	-	•	•	•	-	•	•	-	-	•	-	-	-	-	-	-	-
8	14	-	-	-	-	-	•	•	-	•	•	-	-	•	-	-	-	-	-	-	-
9	12	-	-	-	-	•	-	•	-	•	-	-	-	-	-	-	-	-	-	-	-
9	14	-	-	-	-	-	-	•	-	•	-	-	-	•	-	-	-	-	-	-	-
10	13	-	-	-	-	-	-	•	-	•	•	-	-	•	-	•	-	-	-	-	-
10	14	-	-	-	-	-	•	•	-	-	•	-	-	•	-	•	-	-	-	-	-
10	15	-	-	-	-	-	-	•	-	•	•	-	-	•	-	•	-	-	-	-	-
10	16	-	-	-	-	-	•	•	-	•	•	-	-	•	-	•	-	-	-	-	-
10	18	-	-	-	-	-	-	•	-	•	•	-	-	•	-	•	-	-	-	-	-
12	14	-	-	-	-	-	-	•	-	•	-	-	-	•	-	•	-	-	-	-	-
12	15	-	-	-	-	-	-	•	-	•	•	-	-	•	-	•	-	-	-	-	-
12	16	-	-	-	-	-	•	•	-	•	•	-	-	•	-	•	-	-	-	-	-
12	17	-	-	-	-	-	-	•	-	•	•	-	-	•	-	•	-	-	-	-	-
12	18	-	-	-	-	-	•	•	-	•	•	-	-	•	-	•	-	•	-	-	-
12	20	-	-	-	-	-	-	•	-	•	-	-	-	•	-	•	-	•	-	-	-
14	18	-	-	-	-	-	-	•	-	•	•	-	-	•	-	•	-	•	-	-	-
14	20	-	-	-	-	-	-	•	-	•	•	-	-	•	-	•	-	•	-	-	-
14	22	-	-	-	-	-	-	-	-	•	•	-	-	•	-	•	-	•	-	-	-
15	18	-	-	-	-	-	-	-	-	•	•	-	-	•	-	•	-	•	-	-	-
15	19	-	-	-	-	-	-	•	-	-	•	-	-	•	-	•	-	-	•	-	-
15	20	-	-	-	-	-	-	•	-	•	-	-	-	•	-	•	-	•	-	-	-
15	21	-	-	-	-	-	-	•	-	-	•	-	-	•	-	•	-	-	•	-	-
15	22	-	-	-	-	-	-	-	-	•	•	-	-	•	-	•	-	•	-	-	-
16	20	-	-	-	-	-	-	-	-	•	•	-	-	•	-	•	-	•	-	-	-
16	22	-	-	-	-	-	-	-	-	•	•	-	-	•	-	•	-	•	-	•	-
17	22	-	-	-	-	-	-	-	-	•	•	-	-	•	-	•	-	•	-	•	-
18	22	-	-	-	-	-	-	-	-	•	•	-	-	•	-	•	-	•	-	-	•
18	24	-	-	-	-	-	-	-	-	•	-	-	-	•	-	•	-	•	-	-	•
18	25	-	-	-	-	-	-	-	-	-	•	-	-	•	-	•	-	•	-	•	•

Continúa en la siguiente página...
Continue next page...

Forma de pedido: A + D1*D2*L
How to order: A + D1*D2*L

D1	D2	L																							
		15	16	18	20	22	24	25	28	30	32	35	36	38	40	45	50	55	56	60	63	70	80	90	120
20	24	-	•	-	•	-	-	•	-	-	•	-	-	-	-	-	-	-	-	-	-	-	-	-	-
20	25	•	•	-	•	-	-	•	-	•	•	•	-	-	-	-	-	-	-	-	-	-	-	-	-
20	26	•	•	-	•	-	-	•	-	•	•	•	-	-	-	-	-	-	-	-	-	-	-	-	-
20	27	-	•	-	•	-	-	•	-	-	•	-	-	-	-	-	-	-	-	-	-	-	-	-	-
20	28	-	•	-	•	-	-	•	-	•	•	•	-	-	•	-	-	-	-	-	-	-	-	-	-
20	30	-	-	-	•	-	-	•	-	•	-	•	-	•	-	-	-	-	-	-	-	-	-	-	-
22	27	•	-	•	•	•	-	•	•	•	-	•	•	-	•	-	-	-	-	-	-	-	-	-	-
22	28	-	-	•	•	•	-	•	•	•	-	•	•	-	•	-	-	-	-	-	-	-	-	-	-
22	29	-	-	•	-	•	-	•	-	-	-	•	-	-	-	-	-	-	-	-	-	-	-	-	-
25	30	-	-	-	•	-	-	•	-	•	•	•	-	-	•	-	-	-	-	-	-	-	-	-	-
25	32	-	-	-	•	-	-	•	-	•	•	•	-	-	•	-	-	-	-	-	-	-	-	-	-
25	35	-	-	-	-	-	-	•	-	•	-	•	-	-	•	•	•	-	-	-	-	-	-	-	-
28	32	-	-	-	•	•	-	•	•	-	•	-	•	-	•	-	-	-	-	-	-	-	-	-	-
28	33	-	-	-	•	•	-	•	•	-	•	-	•	-	•	•	-	-	-	-	-	-	-	-	-
28	35	-	-	-	-	-	-	•	-	•	-	•	-	•	•	•	-	-	-	-	-	-	-	-	-
28	36	-	-	-	-	•	-	-	•	-	-	-	•	-	-	•	-	-	•	-	-	-	-	-	-
30	35	-	-	-	•	-	-	•	-	•	-	•	-	•	•	•	-	-	-	-	-	-	-	-	-
30	38	-	-	-	•	-	•	•	-	•	-	•	-	•	•	•	-	-	-	-	-	-	-	-	-
30	40	-	-	-	•	-	-	•	-	•	-	•	-	-	•	•	•	-	-	-	-	-	-	-	-
32	38	-	-	-	•	-	-	•	-	-	•	-	-	-	•	•	•	-	-	-	-	-	-	-	-
32	40	-	-	-	•	-	-	•	-	•	•	•	-	-	•	•	•	-	-	-	-	-	-	-	-
35	40	-	-	-	•	-	-	•	-	•	-	•	-	-	•	•	•	-	-	-	-	-	-	-	-
35	41	-	-	-	-	-	-	•	-	-	-	•	-	-	•	-	-	-	-	-	-	-	-	-	-
35	44	-	-	-	-	•	-	-	•	-	•	-	-	-	-	•	•	-	-	-	-	-	-	-	-
35	45	-	-	-	-	-	-	•	-	•	-	•	-	-	•	•	•	-	-	•	-	-	-	-	-
36	42	-	-	-	-	•	-	-	•	-	-	-	•	-	-	•	-	-	-	-	-	-	-	-	-
36	45	-	-	-	-	•	-	-	•	-	-	-	•	-	-	•	-	-	-	-	-	-	-	-	-
38	44	-	-	-	-	-	-	•	-	-	-	•	-	-	-	•	-	-	-	-	-	-	-	-	-
40	45	-	-	-	-	-	-	-	-	-	-	•	-	-	•	•	•	-	-	-	-	-	-	-	-
40	46	-	-	-	-	-	-	•	-	-	•	•	-	-	-	•	•	•	-	-	-	-	-	-	-
40	50	-	-	-	-	-	-	•	-	-	•	-	-	-	•	•	•	-	-	•	-	-	-	-	-
45	51	-	-	-	-	-	-	-	•	-	-	-	•	-	-	•	-	-	•	-	-	-	-	-	-
45	55	-	-	-	-	-	-	-	•	-	•	-	•	-	•	•	•	•	-	•	-	-	-	-	-
45	56	-	-	-	-	-	-	-	•	-	-	-	•	-	-	•	-	-	•	-	-	-	-	-	-
45	60	-	-	-	-	-	-	-	-	-	-	-	-	-	•	•	•	-	-	•	-	-	-	-	-
50	56	-	-	-	-	-	-	-	-	-	•	-	-	-	•	-	•	-	-	-	•	-	-	-	-
50	60	-	-	-	-	-	-	-	-	-	•	-	-	-	•	•	•	-	-	•	-	-	-	-	-
55	65	-	-	-	-	-	-	-	-	-	-	-	-	-	•	-	-	•	-	-	•	-	-	-	-
60	70	-	-	-	-	-	-	-	-	-	-	-	-	-	-	-	•	-	-	•	-	-	-	•	•
60	72	-	-	-	-	-	-	-	-	-	-	-	-	-	-	-	•	-	-	•	-	-	•	-	-
60	80	-	-	-	-	-	-	-	-	-	-	-	-	-	-	-	-	-	-	-	-	-	-	•	•
63	70	-	-	-	-	-	-	-	-	-	-	-	-	-	•	-	•	-	-	-	-	-	-	-	-
70	80	-	-	-	-	-	-	-	-	-	-	-	-	-	-	-	-	-	-	-	-	-	-	•	•
80(G8)		-	-	-	-	-	-	-	-	-	-	-	-	-	-	-	-	-	-	-	-	-	-	•	•
100(G8)		-	-	-	-	-	-	-	-	-	-	-	-	-	-	-	-	-	-	-	-	-	-	•	•

Forma de pedido: A + D1*D2*L
How to order: A + D1*D2*L

CASQUILLO AUTOLUBRICADO GLYB SELF-LUBRICATING BUSH GLYB

Material: Acero + PTFE / Steel + PTFE

STOCK

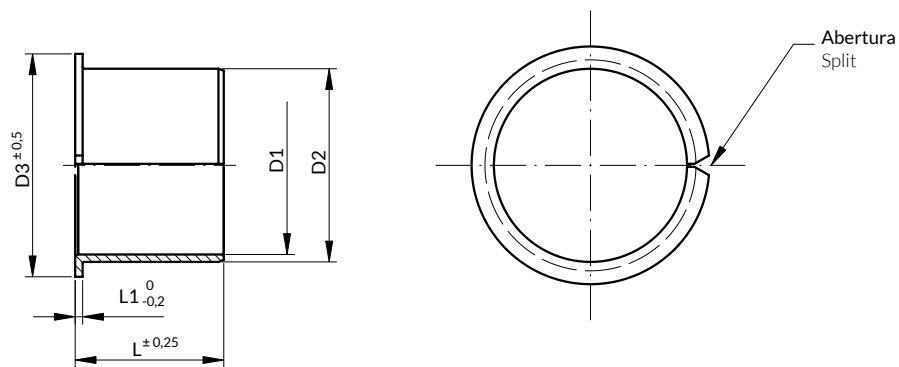

Norma / Standard: DIN 1494 - ISO 3548

D1	D2	D3	L1	L																		
				4	5.5	7	7.5	9	9.5	11.5	12	12.7	15	16	16.5	17	20	21.5	22	26	30	40
6	8	12	1	•	-	•	-	-	-	-	-	•	-	-	-	-	-	-	-	-	-	-
8	10	15	1	•	•	-	•	-	•	-	-	-	-	-	-	-	-	-	-	-	-	-
10	12	18	1	-	-	•	-	•	-	-	•	-	-	-	-	-	•	-	-	-	-	-
12	14	20	1	-	-	•	-	•	-	-	•	-	-	-	-	-	•	-	-	-	-	-
14	16	22	1	-	-	-	-	-	-	-	•	-	-	-	-	-	•	•	-	-	-	-
15	17	23	1	-	-	-	-	•	-	-	•	-	-	-	-	-	•	-	-	-	-	-
16	18	24	1	-	-	-	-	-	-	-	•	-	-	-	-	-	•	-	-	-	-	-
18	20	26	1	-	-	-	-	-	-	-	•	-	-	-	-	-	•	-	-	•	-	-
20	23	30	1.5	-	-	-	-	-	-	•	-	-	•	-	•	-	-	-	•	-	-	-
22	25	32	1.5	-	-	-	-	-	-	•	-	-	-	-	•	-	-	-	-	-	-	-
25	28	35	1.5	-	-	-	-	-	-	•	-	-	-	-	•	-	-	-	•	-	-	-
30	34	42	2	-	-	-	-	-	-	-	-	-	-	-	•	-	-	-	-	-	•	-
35	39	47	2	-	-	-	-	-	-	-	-	-	-	-	•	-	-	-	-	-	•	-
40	44	53	2	-	-	-	-	-	-	-	-	-	-	-	•	-	-	-	-	-	•	•
45	50	60	2.5	-	-	-	-	-	-	-	-	-	-	-	-	-	-	-	-	-	•	•
50	55	65	2.5	-	-	-	-	-	-	-	-	-	-	-	-	-	-	-	-	-	•	•

Forma de pedido: GLYB + D1*L

How to order: GLYB + D1*L

CASQUILLO AUTOLUBRICADO GLY SELF-LUBRICATING BUSH GLY

Material: Acero + PTFE / Steel + PTFE

STOCK

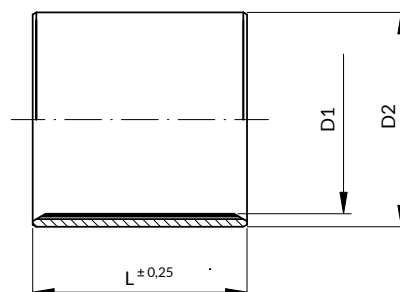

Norma / Standard: DIN 1494 - ISO 3547

D1	D2	L																
		3	4	5	6	8	10	12	15	20	25	30	35	40	45	50	60	70
3	4.5	•	•	•	•	-	-	-	-	-	-	-	-	-	-	-	-	-
4	5.5	•	•	•	•	-	•	-	-	-	-	-	-	-	-	-	-	-
5	7	-	-	•	-	•	•	-	-	-	-	-	-	-	-	-	-	-
6	8	-	•	•	•	•	•	•	-	-	-	-	-	-	-	-	-	-
7	9	-	-	-	-	-	•	-	-	-	-	-	-	-	-	-	-	-
8	10	-	-	-	•	•	•	•	•	•	-	-	-	-	-	-	-	-
10	12	-	-	-	•	•	•	•	•	•	•	-	-	-	-	-	-	-
12	14	-	-	-	•	•	•	•	•	•	•	-	-	-	-	-	-	-
13	15	-	-	-	-	-	•	-	-	•	-	-	-	-	-	-	-	-
14	16	-	-	-	-	-	•	•	•	•	•	-	-	-	-	-	-	-
15	17	-	-	-	-	-	•	•	•	•	•	-	-	-	-	-	-	-
16	18	-	-	-	-	-	•	•	•	•	•	-	-	-	-	-	-	-
17	19	-	-	-	-	-	-	•	•	-	-	-	-	-	-	-	-	-
18	20	-	-	-	-	-	•	•	•	•	•	-	-	-	-	-	-	-
20	22	-	-	-	-	-	-	•	•	•	-	-	-	-	-	-	-	-
20	23	-	-	-	-	-	•	•	•	•	•	-	-	-	-	-	-	-
22	25	-	-	-	-	•	•	•	•	•	•	-	-	-	-	-	-	-
24	27	-	-	-	-	-	-	•	•	•	•	-	-	-	-	-	-	-
25	28	-	-	-	-	-	•	•	•	•	•	-	•	-	•	-	-	-
28	32	-	-	-	-	-	-	•	•	•	•	-	-	-	-	-	-	-
30	34	-	-	-	-	-	•	-	•	•	•	•	•	•	-	•	-	-
32	36	-	-	-	-	-	-	-	•	•	•	-	•	-	-	-	-	-
35	39	-	-	-	-	-	-	-	•	•	•	•	•	•	-	•	-	-
38	42	-	-	-	-	-	-	-	-	-	•	-	•	-	-	-	-	-
40	44	-	-	-	-	-	-	-	•	•	•	•	•	•	•	•	-	-
45	50	-	-	-	-	-	-	-	•	-	•	-	•	•	•	-	-	-
50	55	-	-	-	-	-	-	-	•	-	•	-	•	-	•	•	•	-
55	60	-	-	-	-	-	-	-	-	•	•	-	•	-	•	•	•	-
60	65	-	-	-	-	-	-	-	•	•	•	-	•	-	•	•	•	•

Continúa en la siguiente página...
Continue next page...

Forma de pedido: GLY + D1*D2*L
How to order: GLY + D1*D2*L

D1	D2	L								
		30	40	50	60	70	80	100	115	130
65	70	•	-	•	•	•	-	-	-	-
70	75	•	•	•	•	•	•	-	-	-
75	80	•	•	•	•	-	•	-	-	-
80	85	-	•	•	•	-	•	•	-	-
85	90	•	•	-	•	-	-	•	-	-
90	95	•	•	•	•	-	•	•	-	-
95	100	-	-	-	•	-	-	•	-	-
100	105	-	-	•	•	-	•	•	•	-
105	110	-	-	-	•	-	-	-	•	-
110	115	-	-	•	•	-	-	•	•	•
115	120	-	-	•	•	-	-	-	-	-
120	125	-	•	•	•	-	-	•	-	-
125	130	-	-	-	•	-	-	•	-	-
130	135	-	-	-	•	-	-	•	-	-
135	140	-	-	-	•	-	•	•	-	-
140	145	-	-	-	•	-	-	•	-	-
150	155	-	-	•	•	-	•	•	-	-
155	160	-	-	-	•	-	-	•	-	-
160	165	-	-	-	•	-	•	•	-	-
165	170	-	-	-	-	-	-	•	-	-
170	175	-	-	-	•	-	-	-	-	-
180	185	-	-	-	•	-	-	•	-	-
190	195	-	-	-	-	-	-	•	-	-
200	205	-	-	-	-	-	•	•	-	-
210	215	-	-	-	-	-	-	•	-	-
220	225	-	-	-	-	-	-	•	-	-
250	255	-	-	-	-	-	-	•	-	-
300	305	-	-	-	-	-	-	•	-	-

Forma de pedido: GLY + D1*D2*L
 How to order: GLY + D1*D2*L

ARANDELA PARA COLUMNA RTE WASHER FOR PILLAR RTE

Material: 1.1730

STOCK

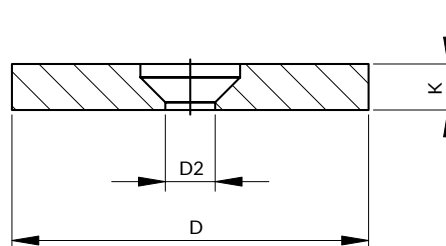

i Recomendación de montaje con tornillo TCO
Assembly recommendation with TCO screw

Código / Code	Ø COL / PILL	D	K	D2
RTE-1	18/19	25	6	9
RTE-2	24/25	32	7	11
RTE-3	30/32	40	7	11
RTE-4	40/42	50	9	13
RTE-5	50/52	62	9	13
RTE-6	63	73	9	13
RTE-7	80	93	12	13

Forma de pedido: Código
How to order: Code

ARANDELA PARA COLUMNA RTI WASHER FOR PILLAR RTI

Material: 1.1730

STOCK

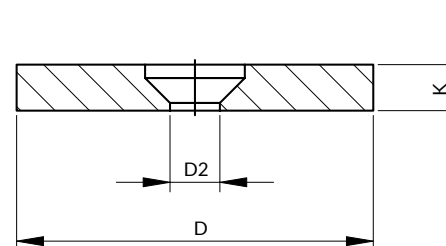

i Recomendación de montaje con tornillo TCO
Assembly recommendation with TCO screw

Código / Code	Ø COL / PILL	D	K	D2
RTI-1	19/20	25	6	8,5
RTI-2	24/25	32	6	8,5
RTI-3	30/32	40	6	8,5
RTI-4	38/40	50	6	8,5
RTI-5	48/50	60	6	8,5
RTI-6	60/63	70	6	8,5
RTI-7	80	93	12	12,5

Forma de pedido: Código
How to order: Code

BRIDA DE RETENCIÓN BRC RETAINING CLAMP BRC

Material: 1.1730

STOCK

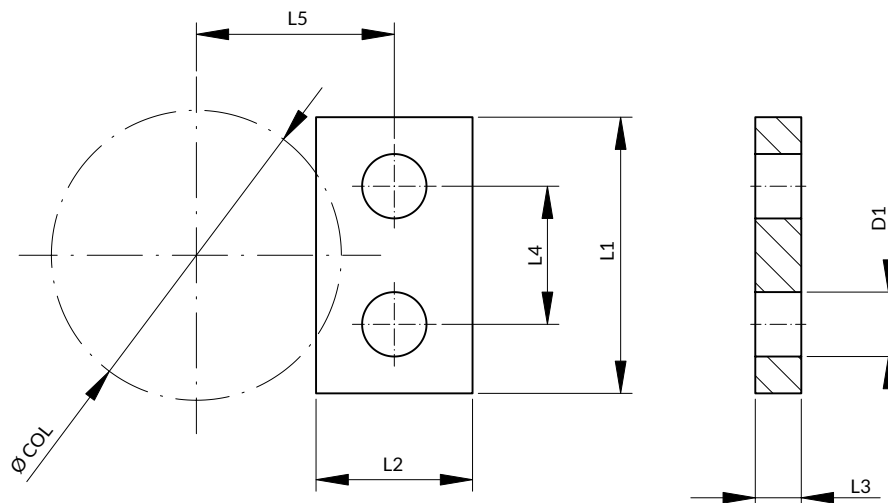

Código / Code	Ø COL / PILL	D1	L1	L2	L3	L4	L5
BRC-2	25	9	40	20	5	20	20,5
BRC-2	32	9	40	20	5	20	24
BRC-2	40	11	48	25	8	24	29,5
BRC-4	50	11	48	25	8	24	33,5
BRC-4	63	14	60	34	10	30	43
BRC-6	80	14	60	34	10	30	50

Forma de pedido: Código
How to order: Code

ANILLO RETENCIÓN COLUMNA ANR RETAINING RING FOR PILLAR ANR

Material: Acero St37 / St 37 steel

STOCK

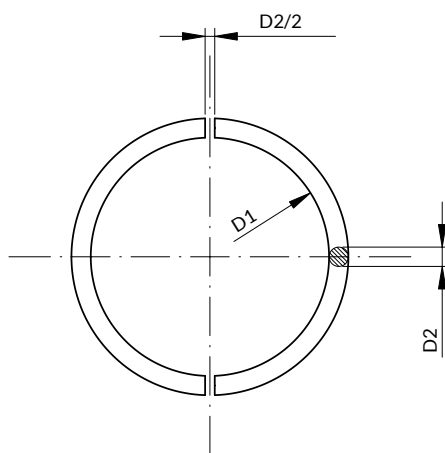

Ø COL / PILL	D1	D2
25	22,5	2,5
32	28	4
40	36	4
50	46	4
63	57	6
80	74	6
100	94	6

Forma de pedido: ANR + Ø COL
How to order: ANR + Ø PILL

BRIDA RETENCIÓN COLUMNA BRCO RETAINING CLAMP FOR PILLAR BRCO

Material: 1.1730

STOCK

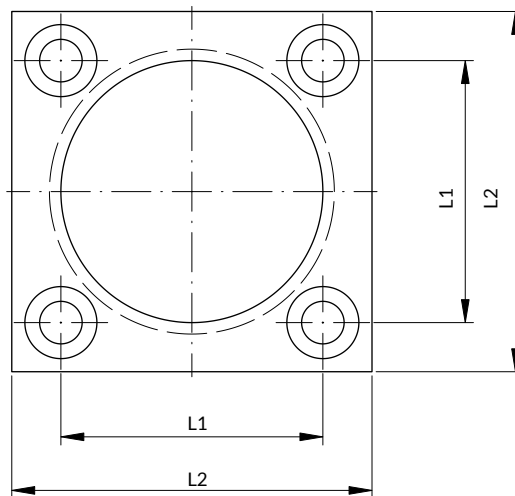
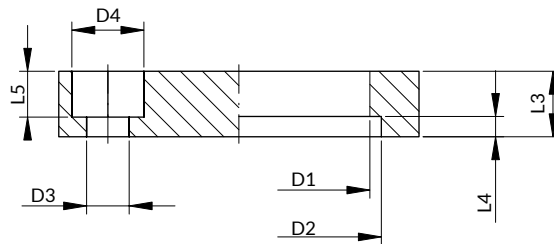

Norma / Standard: AFNOR

D1	D2	D3	D4	L1	L2	L3	L4	L5
25	28	6,6	12	31	45	10	2,7	7
32	37	6,6	12	36	56	10	4,2	7
40	45	6,6	12	50	70	12	4,2	7
50	55	9	16	55	80	14	4,2	9
63	70	11	18	70	100	18	6,2	11
80	87	13	22	80	110	20	6,2	14
100	107	13	22	100	140	20	6,2	14

Forma de pedido: BRCO + D1

How to order: BRCO + D1

BRIDA DE RETENCIÓN BRE 5

RETAINING CLAMP BRE 5

STOCK

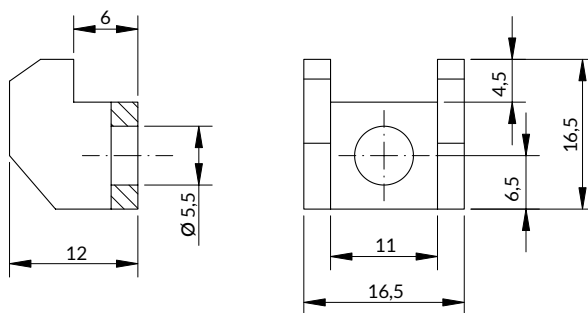

BRIDA DE RETENCIÓN BRE 6

RETAINING CLAMP BRE 6

STOCK

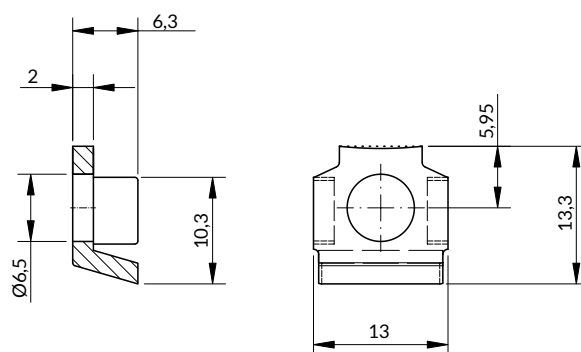

BRIDA DE RETENCIÓN BRE 8

RETAINING CLAMP BRE 8

STOCK

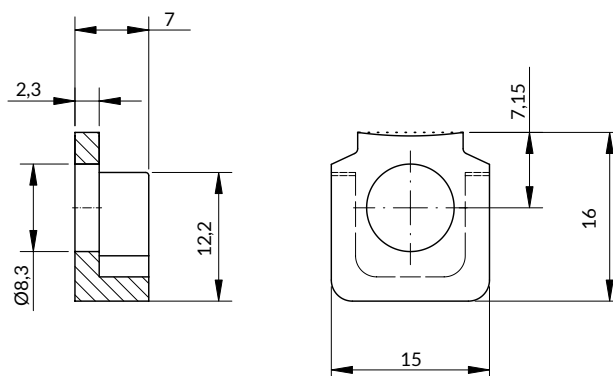

BRIDA DE RETENCIÓN BRE A8

RETAINING CLAMP BRE A8

STOCK

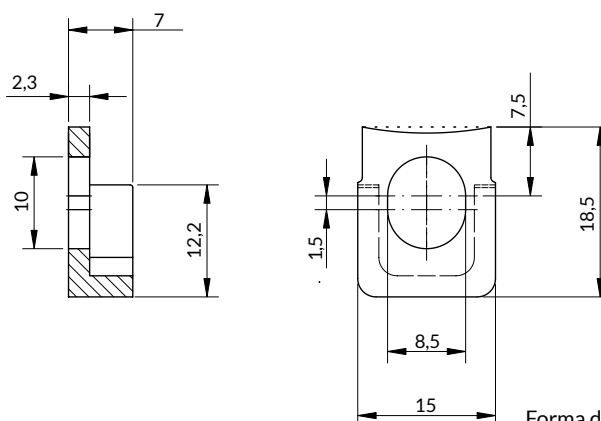

Forma de pedido: BRE_
How to order: BRE_

BRIDA DE RETENCIÓN BREI 6 RETAINING CLAMP BREI 6

STOCK

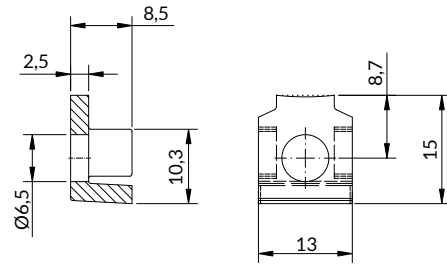

BRIDA DE RETENCIÓN BREI 8 RETAINING CLAMP BREI 8

STOCK

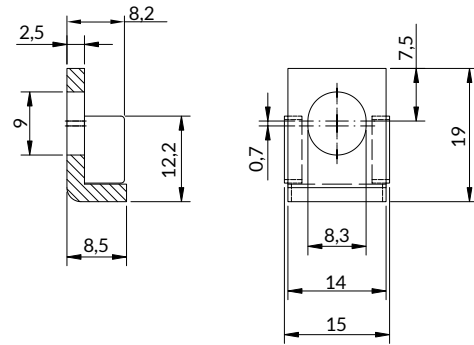

BRIDA DE RETENCIÓN BREI 8P RETAINING CLAMP BREI 8P

STOCK

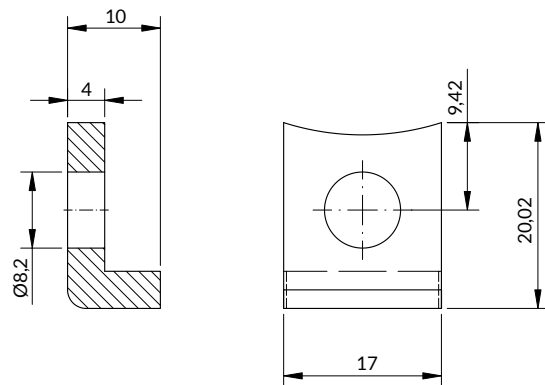

BRIDA DE RETENCIÓN BREI14 RETAINING CLAMP BREI14

STOCK

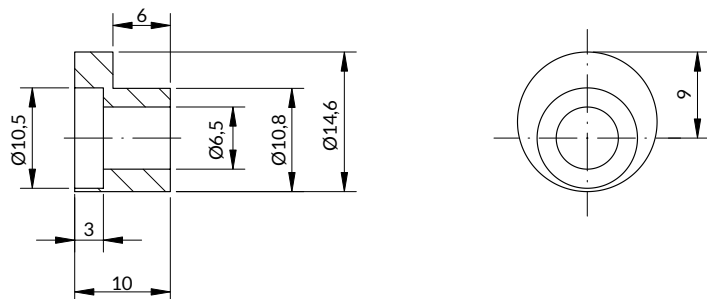

BRIDA DE RETENCIÓN BREI 23 RETAINING CLAMP BREI23

STOCK

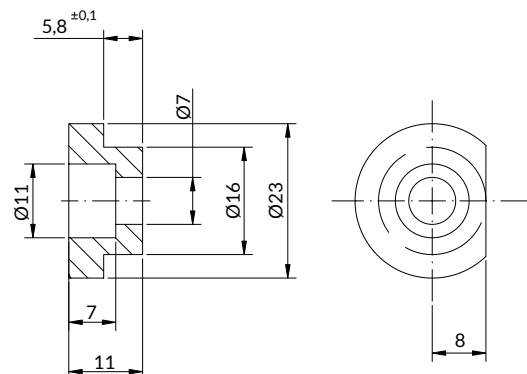

Forma de pedido: BREI_
How to order: BREI_

BRIDA DE RETENCIÓN BRW TOE CLAMP BRW

Material: 1.1730

STOCK

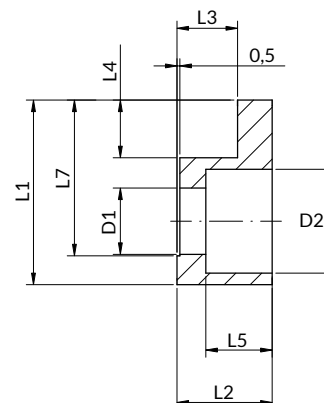
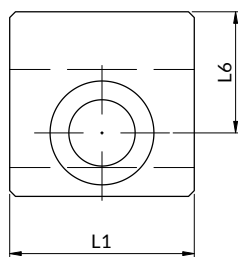

i Recomendación de montaje con tornillo TCC
Assembly recommendation with TCC screw

Norma / Standard: DIN 9832

Ø CASQ. / BUSH	L1	L2	L3	L4	L5	L6	L7	D1	D2	Tornillo / Screw
25-50	20	10	6,3	5	7	12,5	16	7	11	M6
63-160	32	16	10	10	11,5	21	27	11,5	18	M10

Forma de pedido: BRW + L1

How to order: BRW + L1

BRIDA DE RETENCIÓN BRM TOE CLAMP BRM

Material: 1.1730

STOCK

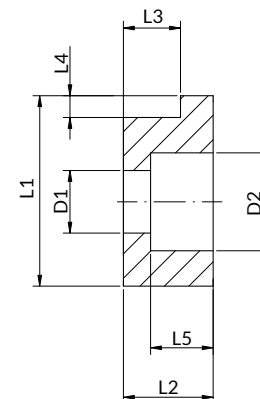
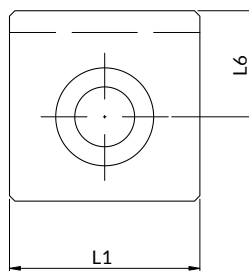

i Recomendación de montaje con tornillo TCC
Assembly recommendation with TCC screw

Ø CASQ. / BUSH	L1	L2	L3	L4	L5	L6	D1	D2
20	16	10	4	4	5,5	10	5,5	10
25	16	10	5	4	6	10	5,5	10
32	16	10	6	4	6	10	5,5	10
40	25	12	8	4	7	14,5	6,6	12
50	30	16	10	4	9	17	9	16
63	35	20	12	4	11	19,5	11	18
80	45	25	16	4	13	24,5	14	22
100	50	32	20	4	13	27	14	22

Forma de pedido: BRM + Ø CASQ.

How to order: BRM + Ø BUSH

BRIDA DE RETENCIÓN BRN TOE CLAMP BRN

Material: 1.1730

STOCK

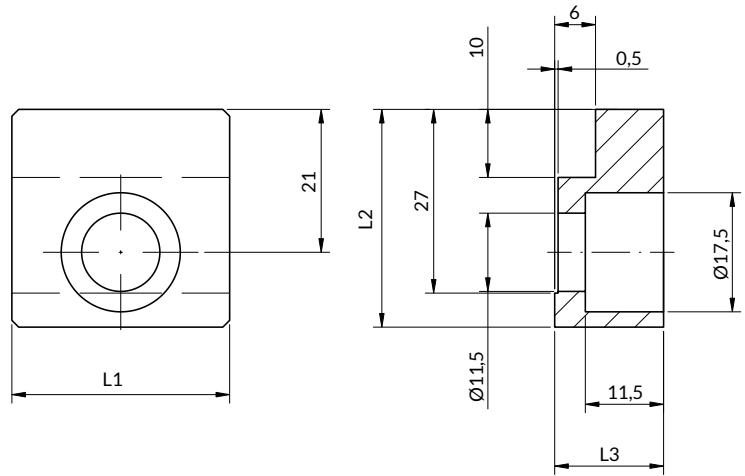

i Recomendación de montaje con tornillo TCC
Assembly recommendation with TCC screw

L1	L2	L3	Tornillo / Screw
32	32	16	M10

Forma de pedido: BRN + L1

How to order: BRN + L1

BRIDA DE RETENCIÓN BRT TOE CLAMP BRT

Material: 1.1730

STOCK

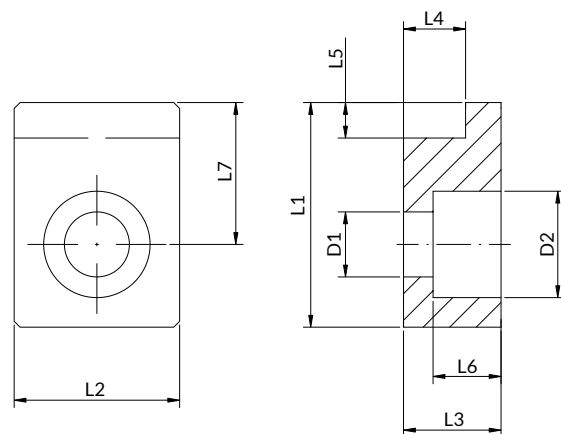

i Recomendación de montaje con tornillo TCC
Assembly recommendation with TCC screw

Ø CASQ. / BUSH	L1	L2	L3	L4	L5	L6	L7	D1	D2
20-42	31	22	12	8	4	8	20	9	15
50-100	38	28	20	12	6	10	24	11	18

Forma de pedido: BRT + L1

How to order: BRT + L1

BRIDA MECANIZADA BRO TOE CLAMP BRO

Material: 1.1730

STOCK

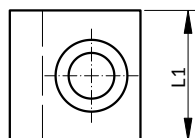
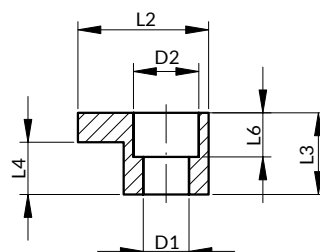
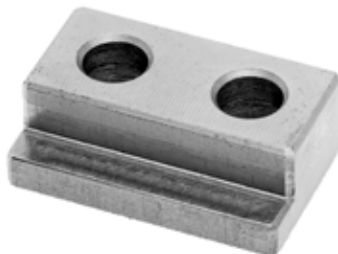

Forma A / Form A

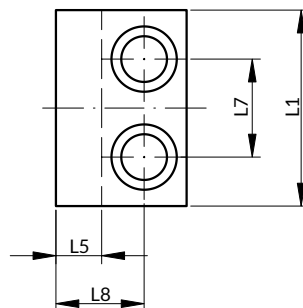

Forma B / Form B



Recomendación de montaje con tornillo TCC
Assembly recommendation with TCC screw

Código / Code	Ø COL. / PILL.	L1	L2	L3	L4	L5	L6	L7	L8	D1	D2	Forma / Form
BRO-1	25-32	20	20	10	5	5	7	-	12,5	7	11	A
BRO-2	40	40	20	12	8	5	7	20	12,5	7	11	B
BRO-3	50	40	25	14	8	6	9	20	15,5	9,5	14,5	B
BRO-4	60-80	50	28	16	10	8	11,5	25	18	11,5	17,5	B
BRO-5	≥ 100	60	40	25	16	14	13,5	30	27	14	20	B

Forma de pedido: Código
How to order: Code

BRIDA PARA CASQUILLO BRCA CLAMP FOR BUSH BRCA

Material: 1.1730

STOCK

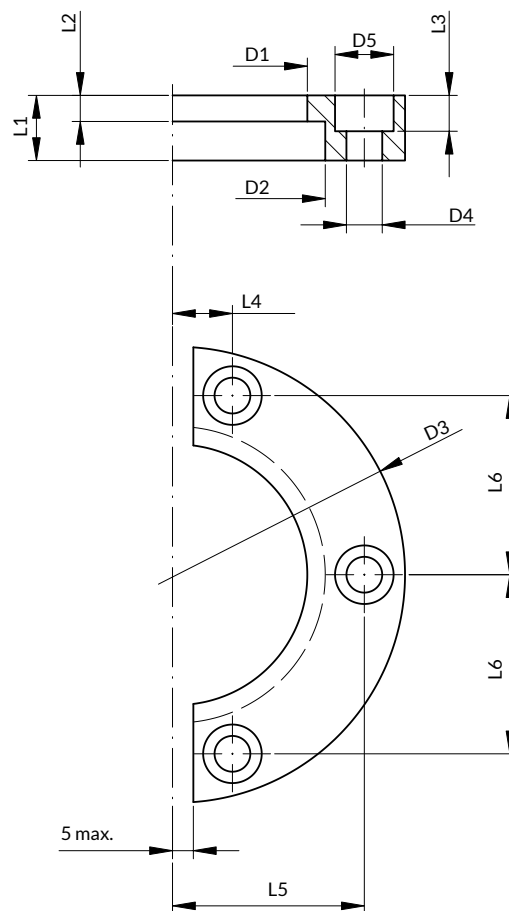

Norma / Standard: AFNOR

Ø CASQ. / BUSH	D1	D2	D3	L1	L2	L3	D4	D5	L4	L5	L6
25	32	41	72	10	5	7	6,6	12	20	-	20
32	40	51	80	12	6	7	6,6	12	21	-	25
40	32	61	100	12	8	7	6,6	12	14	41	38,5
50	63	73	125	16	10	9	9	16	17	49	46
63	80	91	140	20	12	11	11	18	17	57,5	55
80	100	113	180	25	16	13	14	22	20	72	70
100	125	141	200	32	20	13	14	22	25	85	81

Forma de pedido: BRCA + Ø CASQ.

How to order: BRCA + D BUSH

BRIDA PARA CASQUILLO BRCC CLAMP FOR BUSH BRCC

Material: 1.1730

STOCK

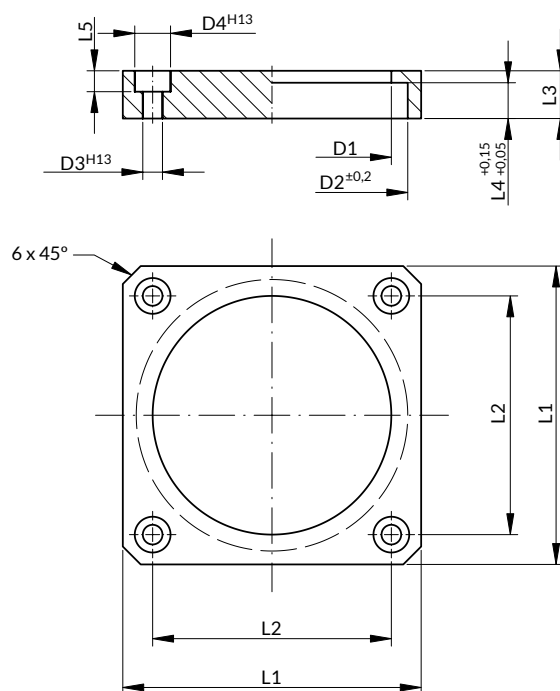
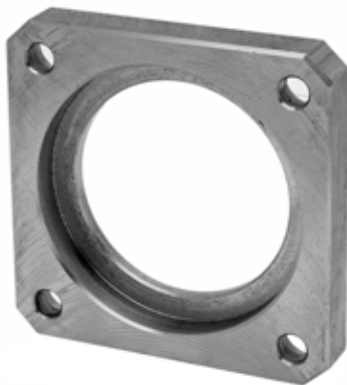

Ø CASQ. / BUSH	D1	D2	D3	D4	L1	L2	L3	L4	L5	L6
40	50	61	6,6	12	75	58	12	8	7	6
50	60	72	9	16	85	65	16	10	9	7
63	80	91	9	16	100	80	16	12	9	7
80	100	113	9	16	117	98	20	16	12	9

Forma de pedido: BRCC + Ø CASQ.
How to order: BRCC + D BUSH

TORNILLO TCI SCREW TCI

Material: 12.9

STOCK

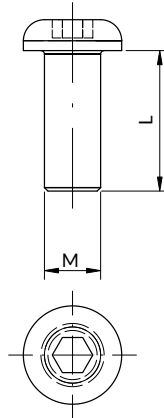

Norma / Standard: ISO 7380

M	L
6	15
8	20

Forma de pedido: TCI + M*L

How to order: TCI + M*L

TORNILLO TCO SCREW TCO

Material: 12.9

STOCK

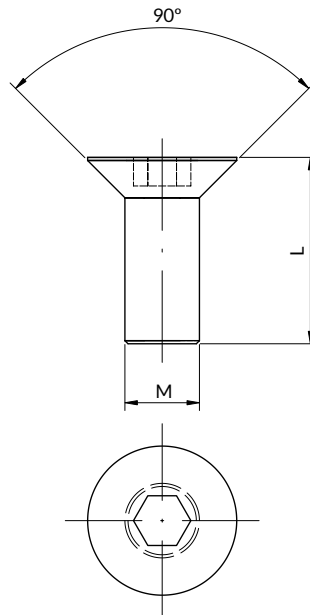

Norma / Standard: DIN 7991 - ISO 10642

M	L
8	20
10	20
12	30

Forma de pedido: TCO + M*L

How to order: TCO + M*L

TORNILLO TCC SCREW TCC

Material: 12.9

STOCK

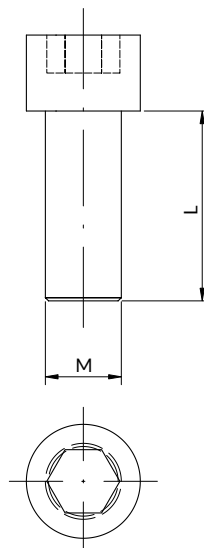

Norma / Standard: DIN 912

M	L
5	16
6	16
8	20
10	20

Forma de pedido: TCC + M*L

How to order: TCC + M*L

PLACA PBGF WEAR PLATE PBGF

Material: Bronce + grafito / Bronze + Graphite
Dureza / Hardness: HB > 190



Forma A / Form A

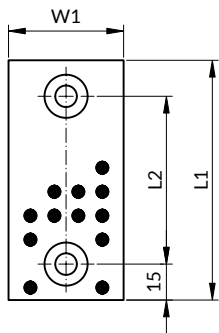

Forma B / Form B

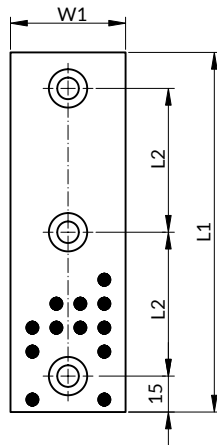

Forma C / Form C

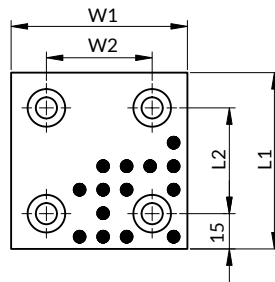

Forma D / Form D

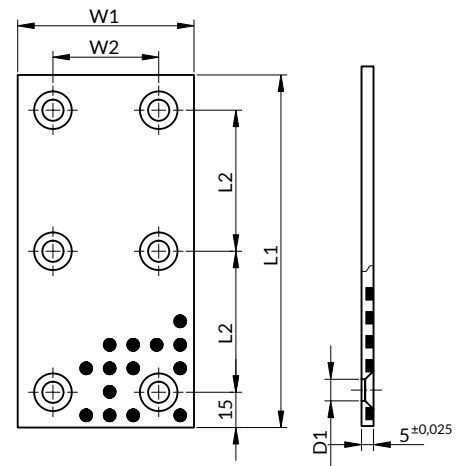

W1	W2	L1	L2	D1	Forma / Form
18	-	50	20	6,5	A
18	-	75	45	6,5	A
18	-	100	70	6,5	A
18	-	150	60	6,5	B
28	-	50	20	9	A
28	-	75	45	9	A
28	-	100	70	9	A
28	-	150	60	9	B
38	-	50	20	9	A
38	-	75	45	9	A
38	-	100	70	9	A
38	-	150	60	9	B
48	-	75	45	9	A
48	-	100	70	9	A
48	-	125	95	9	A
48	-	150	60	9	B
75	45	75	45	9	C
75	45	100	70	9	C
75	45	125	95	9	C
75	45	150	60	9	D
100	70	100	70	9	C
100	70	125	95	9	C
100	70	150	60	9	D

Forma de pedido: PBGF + W1*L1

How to order: PBGF + W1*L1

PLACA PBGL WEAR PLATE PBGL

Material: Bronce + grafito / Bronze + Graphite
Dureza / Hardness: HB > 190



Forma A / Form A

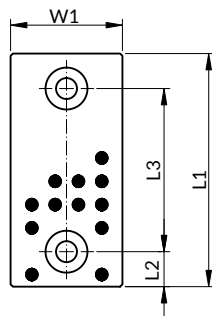

Forma B / Form B

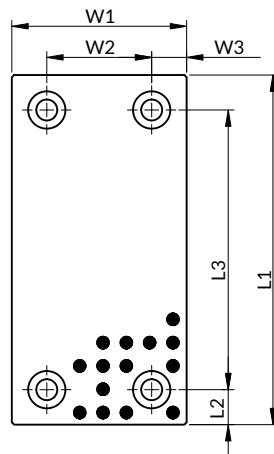

Forma C / Form C

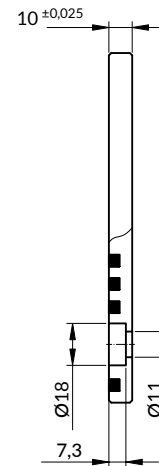
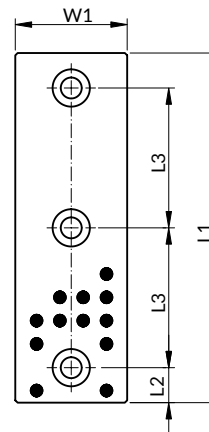

W1	W2	W3	L1	L2	L3	Forma / Form
28	-	-	75	15	45	A
28	-	-	100	25	50	A
28	-	-	125	25	75	A
28	-	-	150	25	100	A
38	-	-	75	15	45	A
38	-	-	100	25	50	A
38	-	-	125	25	75	A
38	-	-	150	25	100	A
48	-	-	75	15	45	A
48	-	-	100	25	50	A
48	-	-	125	25	75	A
48	-	-	150	25	100	A
48	-	-	200	50	100	A
58	-	-	75	15	45	A
58	-	-	100	25	50	A
58	-	-	125	25	75	A
58	-	-	150	25	100	A
58	-	-	200	50	100	A
75	-	-	75	15	45	A
75	-	-	100	25	50	A
75	-	-	125	25	75	A
75	-	-	150	25	100	A
75	-	-	200	25	75	C
100	50	25	100	25	50	B
100	50	25	125	25	75	B
100	50	25	150	25	100	B
100	50	25	200	25	150	B
100	50	25	250	25	200	B
125	50	37,5	150	25	100	B
125	50	37,5	200	25	150	B
125	50	37,5	250	25	200	B
150	100	25	150	25	100	B
150	100	25	200	25	150	B

Forma de pedido: PBGL + W1*L1

How to order: PBGL + W1*L1

PLACA PGBN WEAR PLATE PGBN

Material: Bronce + grafito / Bronze + Graphite
Dureza / Hardness: HB > 190



Forma A / Form A

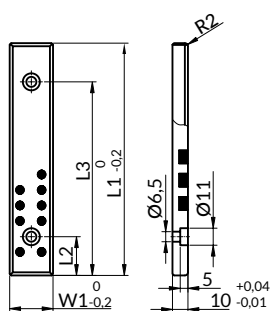

Forma B / Form B

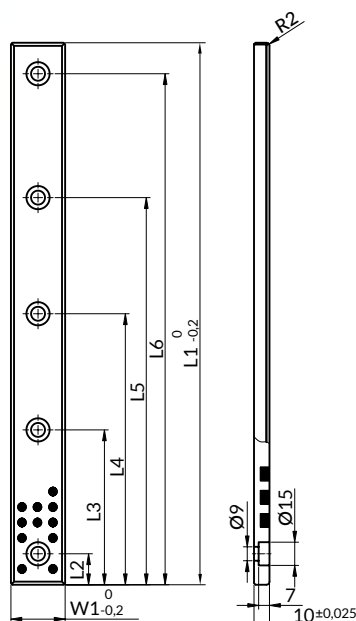

Forma C / Form C

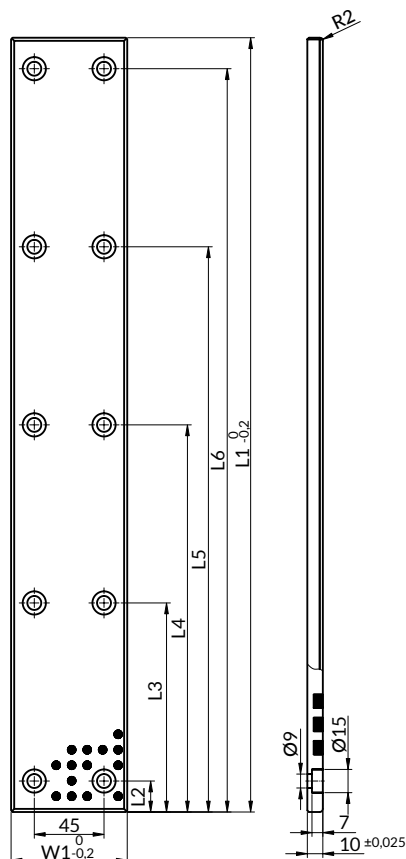

W1	L1	L2	L3	L4	L5	L6	Forma / Form
18	75	15	60	-	-	-	A
18	100	25	75	-	-	-	A
18	125	25	100	-	-	-	A
18	150	25	125	-	-	-	A
28	75	15	60	-	-	-	A
28	100	25	75	-	-	-	A
28	125	25	100	-	-	-	A
28	150	25	125	-	-	-	A
35	100	20	80	-	-	-	B
35	150	20	75	130	-	-	B
35	200	20	75	125	180	-	B
35	250	20	90	160	230	-	B
35	300	20	85	150	215	280	B
35	350	20	100	175	250	330	B
38	75	15	60	-	-	-	A
38	100	25	75	-	-	-	A
38	125	25	100	-	-	-	A
38	150	25	125	-	-	-	A
48	75	15	60	-	-	-	A
48	100	25	75	-	-	-	A
48	125	25	100	-	-	-	A
48	150	25	125	-	-	-	A
50	100	20	80	-	-	-	B
50	150	20	75	130	-	-	B
50	200	20	75	125	180	-	B
50	250	20	90	160	230	-	B
50	300	20	85	150	215	280	B
50	350	20	100	175	250	330	B
50	400	20	110	200	290	380	B
75	150	20	130	-	-	-	C
75	200	20	100	180	-	-	C
75	250	20	125	230	-	-	C
75	300	20	105	195	280	-	C
75	400	20	140	260	380	-	C
75	500	20	135	250	365	480	C

Forma de pedido: PGBN + W*L

How to order: PGBN + W*L

PLACA PBGG - PACG

WEAR PLATE PBGG - PACG

PBGG



Material: Bronce + grafito / Bronze + Graphite
Dureza / Hardness: HB > 190

STOCK

PACG



Material: Acero Cementación / Case Hardened Steel
Dureza / Hardness: 58-60 HRC

STOCK

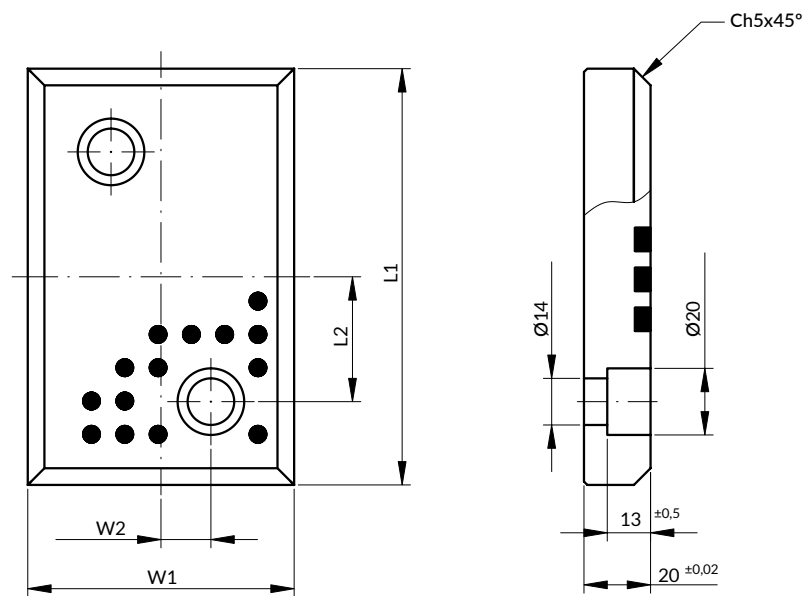

W1	W2	L1	L2
80	15	100	25
80	15	125	37,5

Forma de pedido / How to order: PBGG + W1*L1
PACG + W1*L1

PLACA PBGV - PACV

WEAR PLATE PBGV - PACV

PBGV



Material: Bronce + grafito / Bronze + Graphite
Dureza / Hardness: HB > 190

PACV



Material: Material: Acero Cementación / Case Hardened Steel
Dureza / Hardness: 58-60 HRC

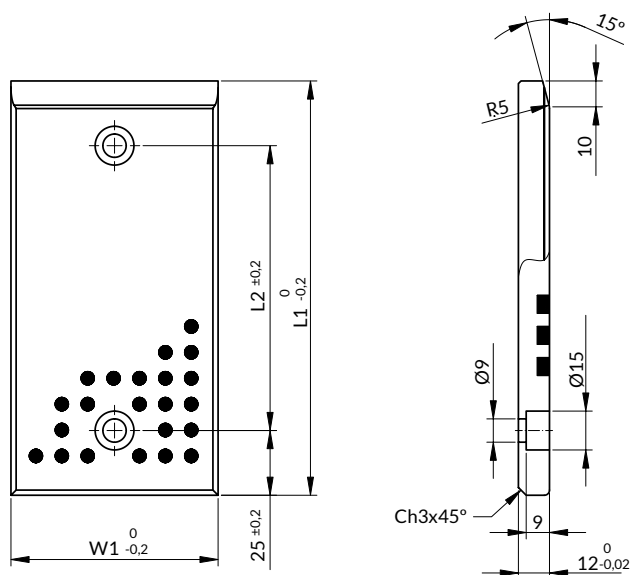

Norma / Standard: VDI 3357

W1	L1	L2
30	80	30
30	100	50
30	125	75
30	160	110
30	200	150
40	80	30
40	100	50
40	125	75
40	160	110
40	200	150
50	80	30
50	100	50
50	125	75
50	160	110
50	200	150
60	80	30
60	100	50
60	125	75
60	160	110
60	200	150
80	80	30
80	100	50
80	125	75
80	160	110
80	200	150

Forma de pedido / How to order: PBGV + W1*L1
PACV + W1*L1

PLACA PSTV WEAR PLATE PSTV

Material: ST 42 + Capa sinterizada
ST 42 + Sintered Layer



Forma A / Form A

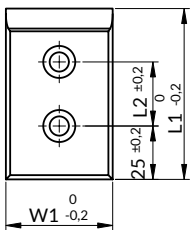

Forma B / Form B

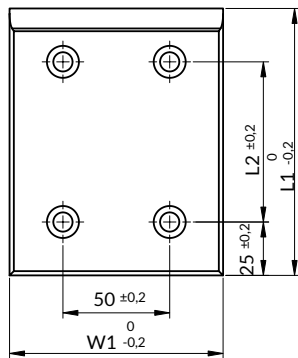

Forma C / Form C

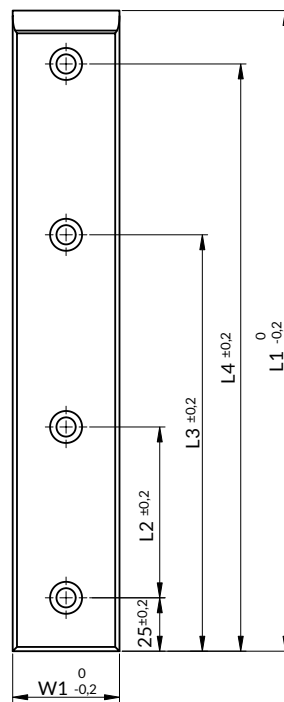

Forma D / Form D

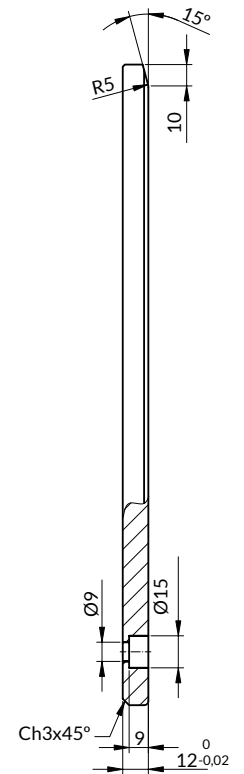
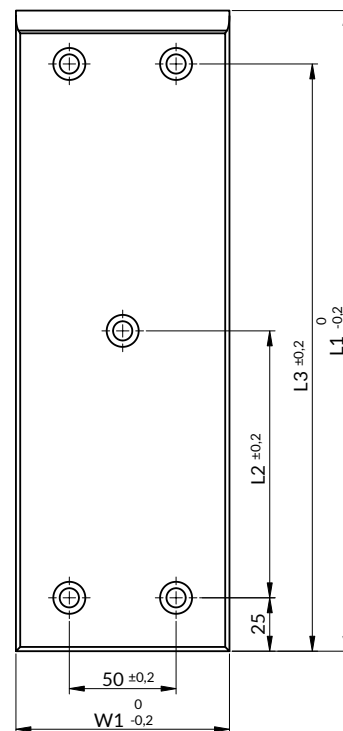

Norma / Standard: VDI 3357

W1	L1	L2	L3	L4	Forma / Form
30	80	30	-	-	A
30	100	50	-	-	A
30	125	75	-	-	A
30	160	110	-	-	A
30	200	150	-	-	A
40	80	30	-	-	A
40	100	50	-	-	A
40	125	75	-	-	A
40	160	110	-	-	A
40	200	150	-	-	A
50	80	30	-	-	A
50	100	50	-	-	A
50	125	75	-	-	A
50	160	110	-	-	A
50	200	150	-	-	A
50	250	60	165	225	C
50	300	80	195	275	C
50	350	100	225	325	C
50	400	120	255	375	C

W1	L1	L2	L3	L4	Forma / Form
60	80	30	-	-	A
60	100	50	-	-	A
60	125	75	-	-	A
60	160	110	-	-	A
60	200	150	-	-	A
80	80	30	-	-	A
80	100	50	-	-	A
80	125	75	-	-	A
80	160	110	-	-	A
80	200	150	-	-	A
100	125	75	-	-	B
100	160	110	-	-	B
100	200	150	-	-	B
100	250	200	-	-	B
100	300	125	275	-	D

Forma de pedido: PSTV + W1*L1

How to order: PSTV + W1*L1

PLACA PBGW - PSTW - PACW
WEAR PLATE PBGW - PSTW - PACW

PBGW



Material: Bronce + grafito
Bronze + Graphite
Dureza / Hardness: HB > 190

PSTW



Material: ST 42 + Capa sinterizada
ST 42 + Sintered Layer

PACW



Material: Acero Cementación
Case Hardened Steel
Dureza / Hardness: 58-60 HRC

Forma A / Form A

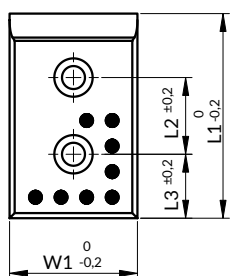

Forma B / Form B

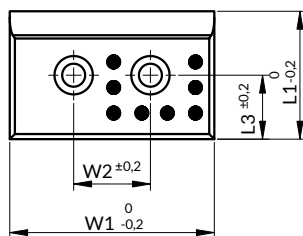

Forma C / Form C

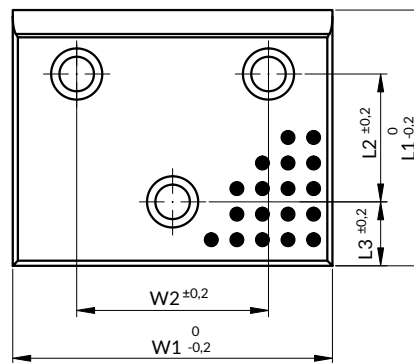

Forma D / Form D

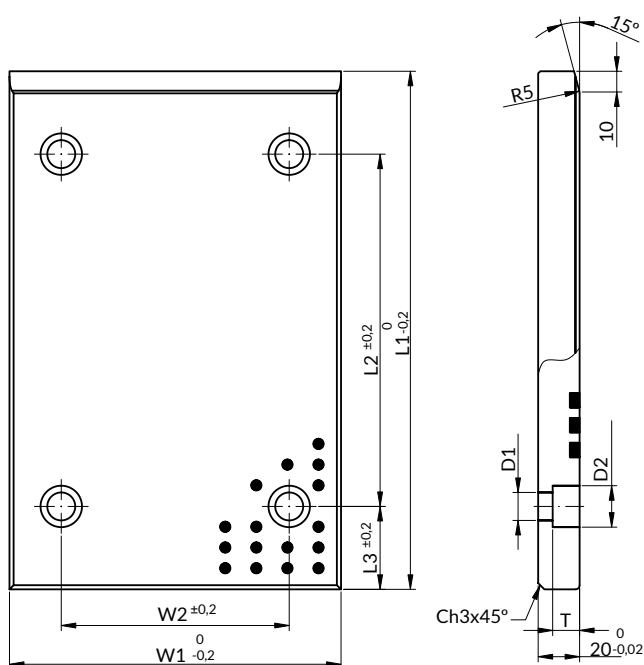

Norma / Standard: VDI 3357

W1	L1	W2	L2	L3	D1	D2	T	Forma / Form
50	80	-	30	25	9	15	9	A
50	100	-	50	25	13,5	20	13	A
50	125	-	75	25	13,5	20	13	A
50	160	-	110	25	13,5	20	13	A
50	200	-	150	25	13,5	20	13	A
80	50	30	-	25	9	15	9	B
80	80	-	30	25	13,5	20	13	A
80	100	-	50	25	13,5	20	13	A
80	125	-	75	25	13,5	20	13	A
80	160	-	110	25	13,5	20	13	A
80	200	-	150	25	13,5	20	13	A
80	250	-	170	25	13,5	20	13	A
100	50	50	-	25	13,5	20	13	B
100	80	50	-	40	13,5	20	13	B
100	100	-	50	25	13,5	20	13	A
100	125	-	75	25	13,5	20	13	A
100	160	-	110	25	13,5	20	13	A
100	200	-	150	25	13,5	20	13	A
100	250	-	170	40	13,5	20	13	A
100	315	-	235	40	13,5	20	13	A
125	50	75	-	25	13,5	20	13	B
125	80	75	-	40	13,5	20	13	B
125	100	75	50	25	13,5	20	13	C
125	125	75	75	25	13,5	20	13	C
125	160	75	110	25	13,5	20	13	C
125	200	75	150	25	13,5	20	13	C
125	250	75	170	40	13,5	20	13	C
125	315	75	235	40	13,5	20	13	C
160	50	110	-	25	13,5	20	13	B
160	80	110	-	40	13,5	20	13	B
160	100	110	50	25	13,5	20	13	C
160	125	110	75	25	13,5	20	13	C
160	160	110	110	25	13,5	20	13	C
160	200	110	150	25	13,5	20	13	C
160	250	110	170	40	13,5	20	13	D
160	315	110	235	40	13,5	20	13	D

Forma de pedido / How to order: PBGW + W1*L1

PSTW + W1*L1

PACW + W1*L1

ÍNDICE
INDEX

PLACA PBGZ WEAR PLATE PBGZ

Material: Bronce + grafito / Bronze + Graphite
Dureza / Hardness: HB > 190

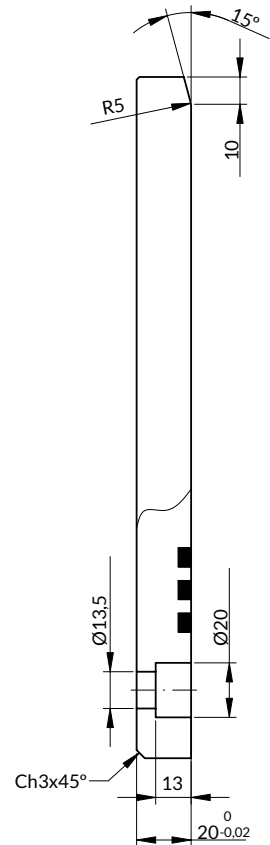
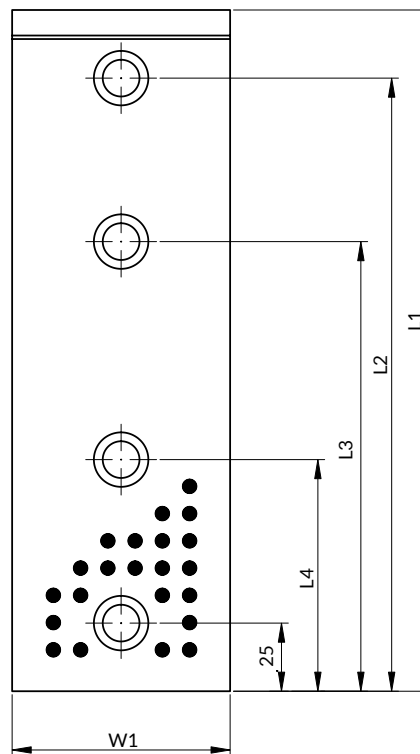

Norma / Standard: VDI 3357

W1	L1	L2	L3	L4
50	250	225	165	85
50	300	275	195	105
50	350	325	225	125
50	400	375	255	145
50	450	425	285	165
50	500	475	325	175
80	250	225	165	85
80	300	275	195	105
80	350	325	225	125
80	400	375	255	145
80	450	425	285	165
80	500	475	325	175
100	250	225	165	85
100	300	275	195	105
100	350	325	225	125
100	400	375	255	145
100	450	425	285	165
100	500	475	325	175
125	250	225	165	85
125	300	275	195	105
125	350	325	225	125
125	400	375	255	145
125	400	375	255	145
125	450	425	285	165
125	500	475	325	175
160	250	225	165	85
160	300	275	195	105
160	350	325	225	125
160	400	375	255	145
160	450	425	285	165
160	500	475	325	175

Forma de pedido: PBGZ + W1*L1

How to order: PBGZ + W1*L1

PLACA PBGH - PACH WEAR PLATE PBGH - PACH

PBGH



Material: Bronce + grafito / Bronze + graphite
Dureza / Hardness: HB > 190

PACH



Material: Acero de cementación / Hardened steel
Dureza / Hardness: 62 ± 2 HRC

Forma A / Form A

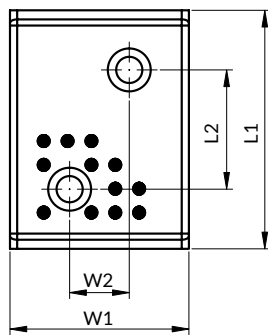

Forma B / Form B

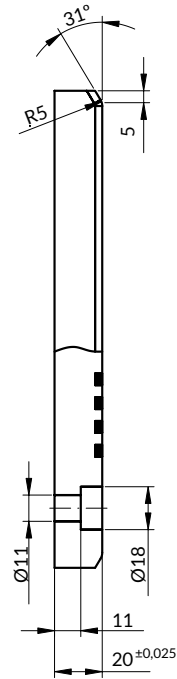
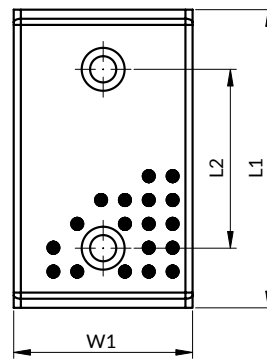

W1	L1	W2	L2	Forma / Form
28	75	-	45	B
28	100	-	50	B
28	125	-	75	B
28	150	-	100	B
28	200	-	150	B
38	75	-	45	B
38	100	-	50	B
38	125	-	75	B
38	150	-	100	B
38	200	-	150	B
48	75	-	45	B
48	100	-	50	B
48	125	-	75	B
48	150	-	100	B
48	200	-	150	B
58	75	-	45	B
58	100	-	50	B
58	150	-	100	B
75	75	25	25	A
75	100	25	50	A
75	125	-	75	B
75	150	-	100	B
75	200	-	150	B

Continúa en la siguiente página...
Continue next page...

Forma de pedido / How to order: PBGH + W1*L1
PACH + W1*L1

Forma C / Form C

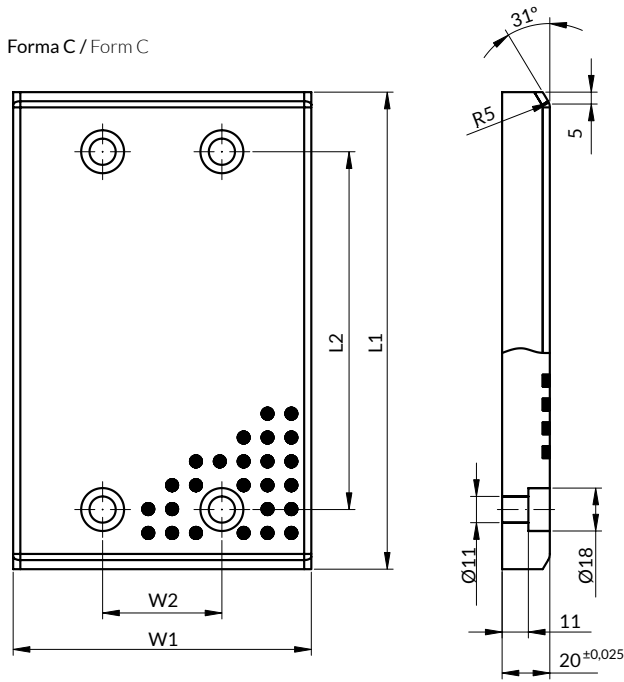

W1	L1	W2	L2	Forma / Form
100	75	50	50	C
100	100	50	75	C
100	125	50	100	C
100	150	50	150	C
100	200	50	200	C
125	125	50	75	C
125	150	50	100	C
125	200	50	150	C
125	250	50	200	C
150	125	100	100	C
150	150	100	150	C
150	200	100	200	C
150	250	100	200	C
150	300	100	250	C

Forma de pedido / How to order: PBGH + W1*L1
PACH + W1*L1

PLACA PBGE WEAR PLATE PBGE

Material: Bronce + grafito / Bronze + graphite
Dureza / Hardness: HB > 190



Forma A / Form A

Forma B / Form B

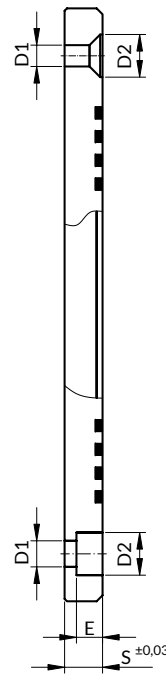
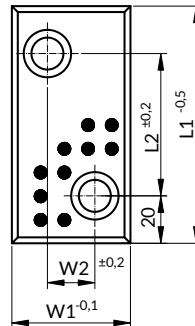
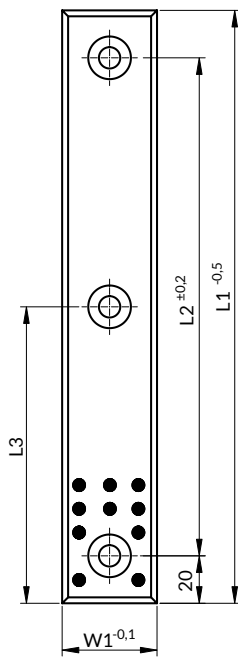

i Recomendación de montaje
Assembly recommendation
S=8: Tornillo TCO
S> 8: Tornillo TCC

W1	W2	S	D1	D2	E	L1			L3	Forma / Form
						100	160	250		
30	-	12	9	15	9	L2=60	L2=120	-	-	A
30	-	12	9	15	9	-	-	L2=210	125	A
40	-	8	9	16,4	-	L2=60	L2=120	-	-	A
40	-	8	9	16,4	-	-	-	L2=210	125	A
40	-	12	9	15	9	L2=60	L2=120	-	-	A
40	-	12	9	15	9	-	-	L2=210	125	A
40	-	16	11	18	11	L2=60	L2=120	-	-	A
40	-	16	11	18	11	-	-	L2=210	125	A
50	20	20	13,5	20	13	L2=60	L2=120	-	-	B
60	30	16	11	18	11	L2=60	L2=120	-	-	B
80	40	12	9	15	9	L2=60	-	-	-	B
80	40	20	13,5	20	13	L2=60	-	-	-	B
100	60	16	11	18	11	L2=60	-	-	-	B

Continúa en la siguiente página...
Continue next page...

Forma de pedido: PBGE + W1*L1*S
How to order: PBGE + W1*L1*S

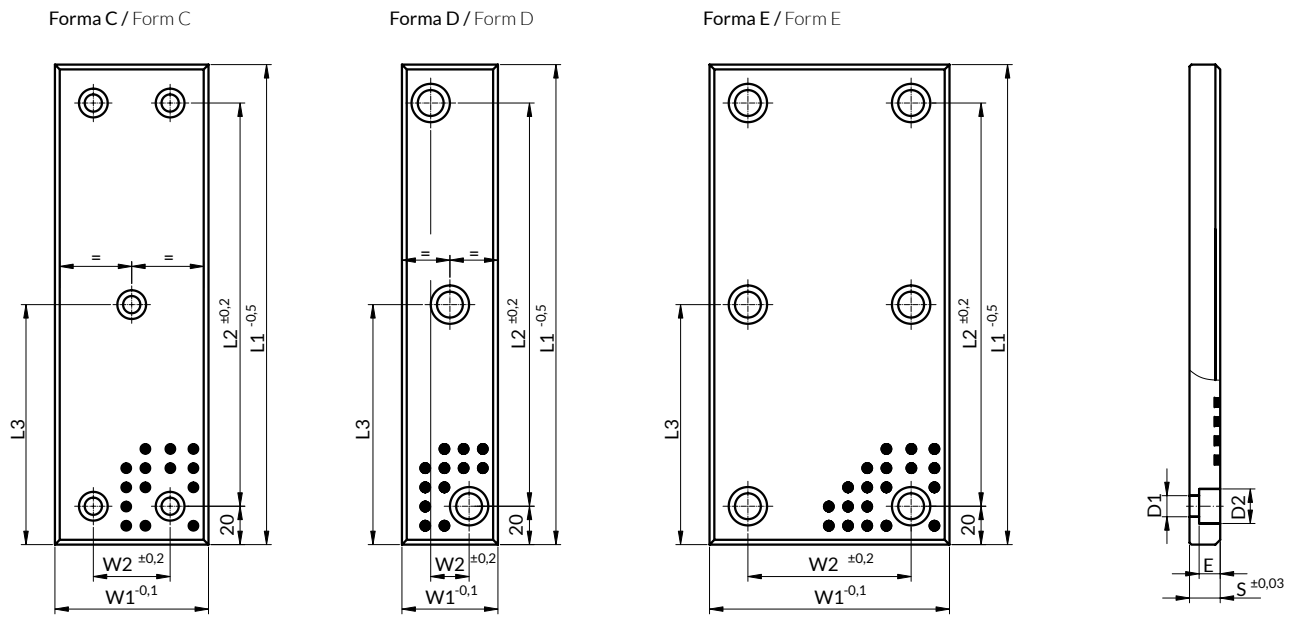

W1	W2	S	D1	D2	E	L1			L3	Forma / Form
						100	160	250		
50	20	20	13,5	20	13	-	-	L2=210	125	D
60	30	16	11	18	11	-	-	L2=210	125	D
80	40	12	9	15	9	-	L2=120	-	-	E
80	40	12	9	15	9	-	-	L2=210	125	C
80	40	20	13,5	20	13	-	L2=120	-	-	E
80	40	20	13,5	20	13	-	-	L2=210	125	C
100	60	16	11	18	11	-	L2=120	-	-	E
100	60	16	11	18	11	-	-	L2=210	125	E
125	85	20	13,5	20	13	L2=60	L2=120	-	-	E
125	85	20	13,5	20	13	-	-	L2=210	125	E

Forma de pedido: PBGE + W1*L1*S
How to order: PBGE + W1*L1*S

PLACA PBGR - PACR

WEAR PLATE PBGR - PACR

PBGR



Material: Bronce + grafito / Bronze + graphite
Dureza / Hardness: HB > 190

PACR



Material: Acero de cementación / Hardened steel
Dureza / Hardness: 62 ± 2 HRC

Forma A / Form A

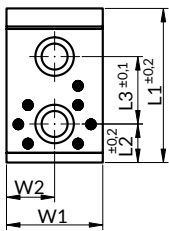

Forma B / Form B

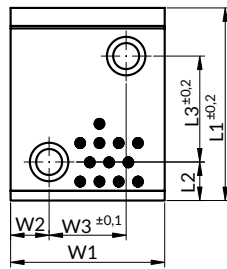

Forma C / Form C

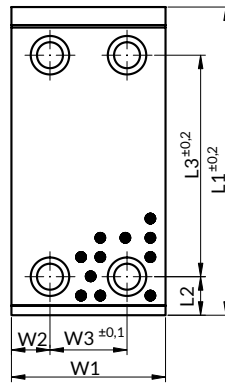

Forma D / Form D

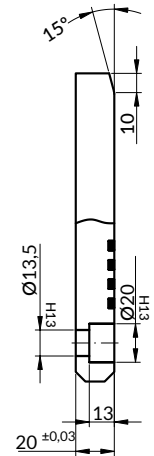
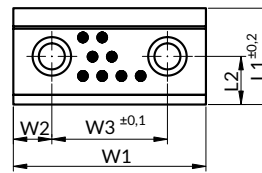

W1	L1	L2	L3	L4	W2	W3	Forma / Form
50	80	20	35	-	25	-	A
50	100	20	55	-	25	-	A
50	125	20	80	-	25	-	A
50	160	20	115	-	25	-	A
50	200	20	155	-	25	-	A
80	100	20	55	40	20	40	B
80	125	20	80	40	20	40	B
80	160	20	115	40	20	40	C
80	200	20	155	40	20	40	C
100	50	25	-	60	20	60	D
100	80	20	35	60	20	60	B
100	100	20	55	60	20	60	B
100	125	20	80	60	20	60	C
100	160	20	115	60	20	60	C
100	200	20	155	60	20	60	C
125	80	20	35	85	20	85	B
125	100	20	55	85	20	85	C
125	125	20	80	85	20	85	C
125	160	20	115	85	20	85	C
125	200	20	155	85	20	85	C
160	100	20	55	120	20	120	C
160	125	20	80	120	20	120	C
160	160	20	115	120	20	120	C

Forma de pedido / How to order: PBGR + W1*L1
PACR + W1*L1

PLACÓN PAGW PLATE PAGW

Material: CK45 + Grafito / CK45 + Graphite

Dureza en superficie de deslizamiento / Sliding surface hardness: 58-60 HRC



Forma A / Form A

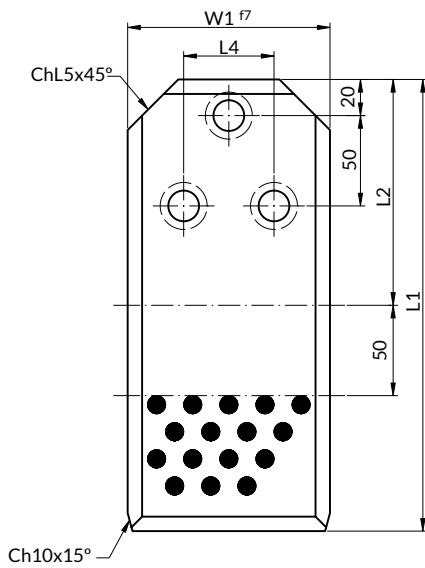

Forma B / Form B

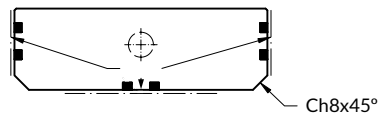
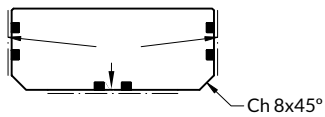
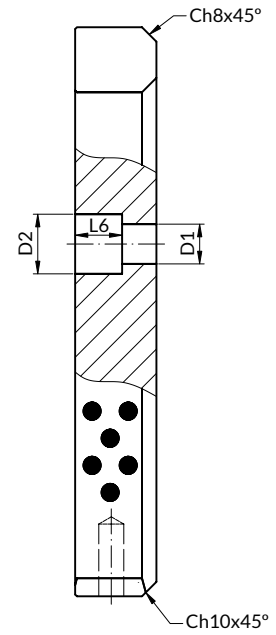
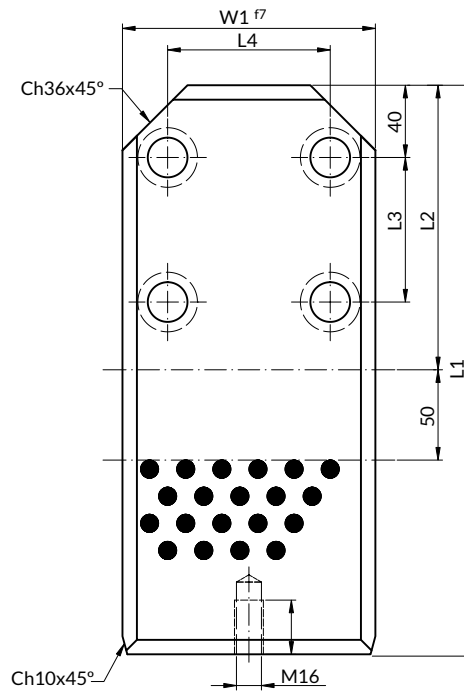

Norma / Standard: VDI 3387

W1	L1	S	L6	D1	D2	L3	L4	L5	L2	Forma / Form
63	180	36	16	13	20	-	36	18	90	A
63	200	36	16	13	20	-	36	18	90	A
63	224	36	16	13	20	-	36	18	90	A
71	180	36	16	13	20	-	36	18	90	A
71	200	36	16	13	20	-	36	18	90	A
71	224	36	16	13	20	-	36	18	90	A
90	200	45	21	17	26	-	50	28	100	A
90	224	45	21	17	26	-	50	28	100	A
90	250	45	21	17	26	-	50	28	100	A
112	200	45	21	17	26	-	50	28	100	A
112	224	45	21	17	26	-	50	28	100	A
112	250	45	21	17	26	-	50	28	100	A
140	315	45	26	22	33	80	90	-	150	B
140	400	45	26	22	33	80	90	-	150	B
140	315	56	26	22	33	80	90	-	150	B
190	315	45	26	22	33	80	90	-	150	B
190	400	45	26	22	33	80	90	-	150	B
240	500	56	31	26	40	160	160	-	250	B
240	630	56	31	26	40	160	160	-	250	B

Forma de pedido: PAGW + W1*L1*S

How to order: PAGW + W1*L1*S

ESCUADRA EBGW
ANGULAR GUIDE EBGW

Material: Bronce + grafito / Bronze + graphite
Dureza / Hardness: HB > 190



Forma E / Form E

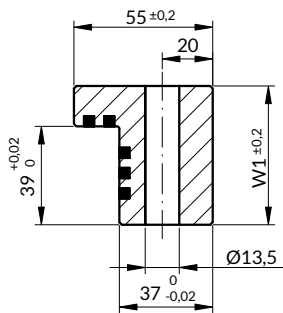

Forma F / Form F

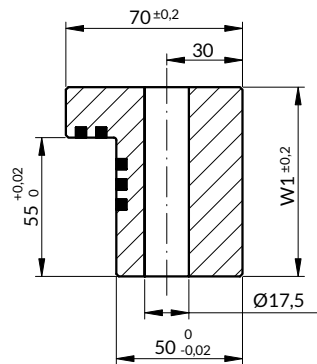

Forma G / Form G

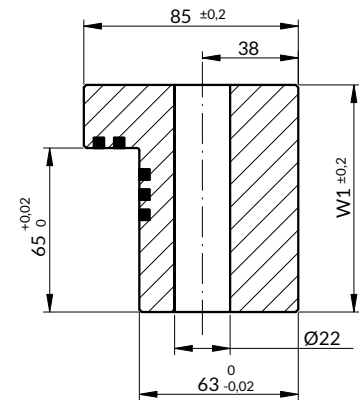

Detalle X / Detail X
Forma E ÷ G / Form E ÷ G

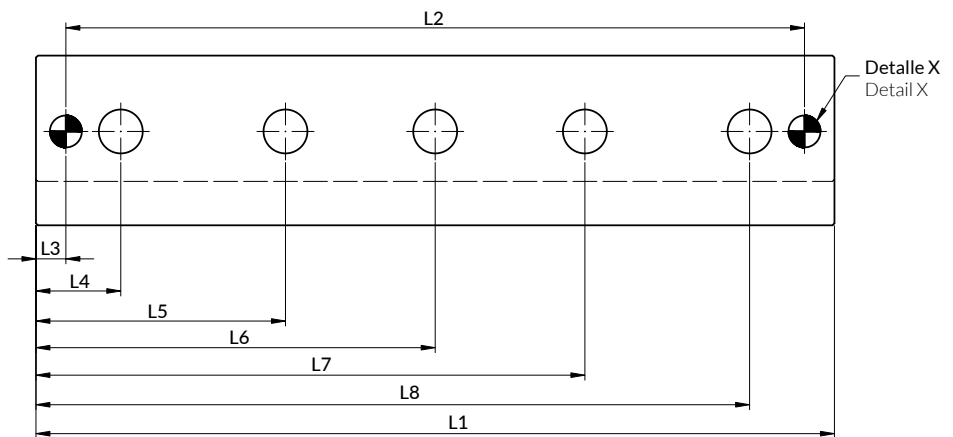
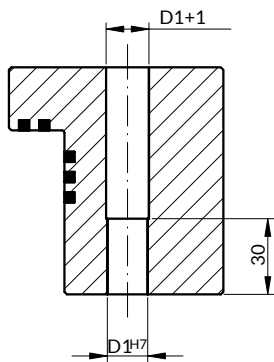

W1	L1	L3	L2	L4	L5	L6	L7	L8	D1	Forma / Form
55	100	10	80	27,5	-	-	-	72,5	10	E
55	160	10	140	27,5	-	-	-	132,5	10	E
75	160	12,5	135	35	-	-	-	125	12	F
75	200	12,5	175	35	-	-	-	165	12	F
75	250	12,5	225	35	-	125	-	215	12	F
75	400	12,5	375	35	125	200	275	365	12	F
90	160	15	130	42,5	-	-	-	117,5	16	G
90	200	15	170	42,5	-	-	-	157,5	16	G
90	250	15	220	42,5	-	125	-	207,5	16	G
90	400	15	370	42,5	125	200	275	357,5	16	G

Forma de pedido: EBGW + W1*L1
How to order: EBGW + W1*L1

ESCUADRA EBGW ANGULAR GUIDE EBGW

Material: Bronce + grafito / Bronze + graphite
Dureza / Hardness: HB > 190



Forma A / Form A

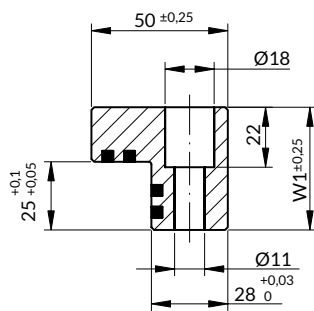

Forma B / Form B

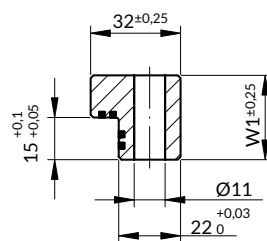

Forma C / Form C

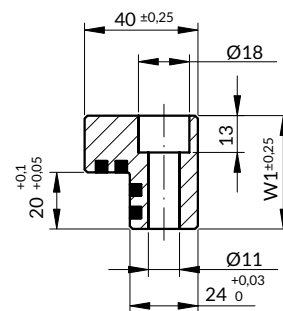

Forma D / Form D

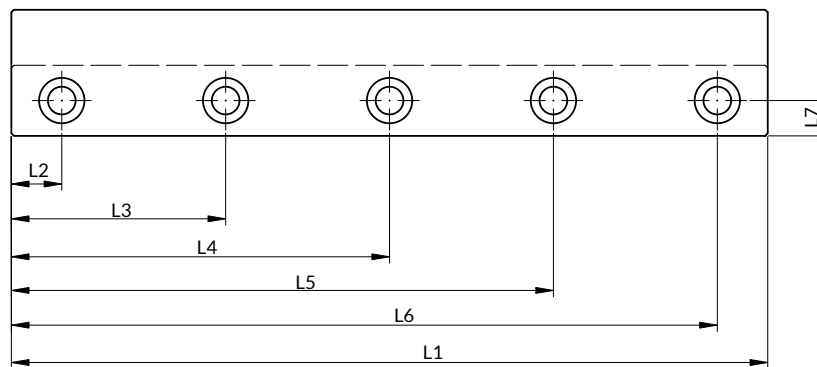
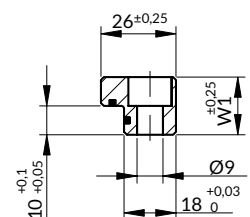

W1	L1	L2	L3	L4	L5	L6	L7	Forma / Form
20	100	20	80	-	-	-	9	D
20	150	20	75	130	-	-	9	D
20	200	20	75	125	180	-	9	D
30	100	20	80	-	-	-	11	B
30	150	20	75	130	-	-	11	B
30	200	20	75	125	180	-	11	B
30	250	20	90	160	230	-	11	B
40	160	15	145	-	-	-	12	C
40	250	15	145	225	-	-	12	C
45	200	20	75	125	180	-	14	A
45	250	20	90	160	230	-	14	A
45	300	20	85	150	215	280	14	A
45	350	20	100	175	250	330	14	A

Forma de pedido: EBGW + W1*L1

How to order: EBGW + W1*L1

GUÍA "V" GACH "V" DRIVER GACH

Material: CK 45

Dureza en superficie de deslizamiento / Sliding surface hardness: 58-60 HRC

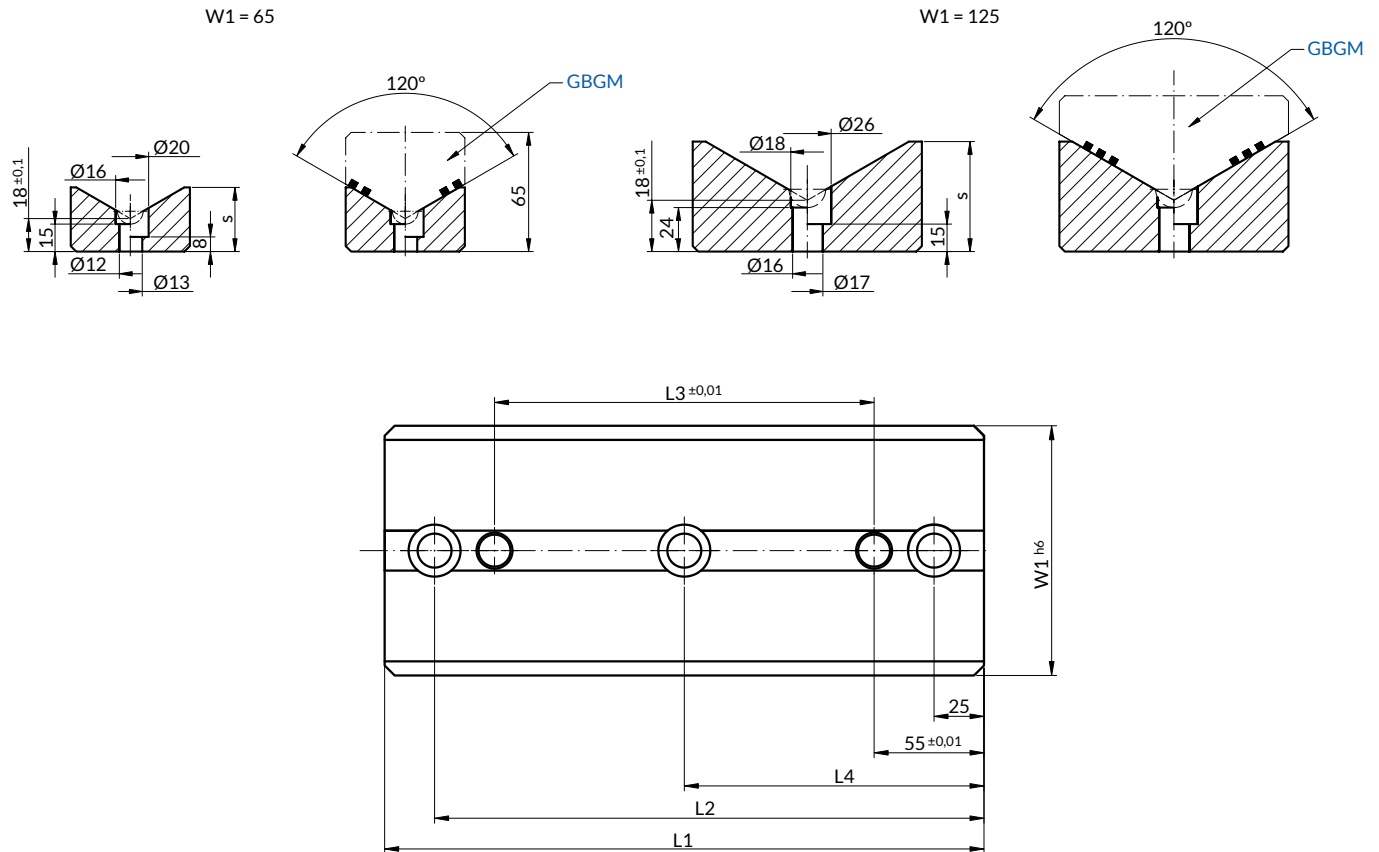

Norma / Standard: VDI 3357

W1	S	L1	L2	L3	L4
65	35	150	125	45	-
65	35	200	175	95	-
65	35	250	225	145	125
65	35	300	275	195	150
125	60	150	125	45	-
125	60	200	175	95	-
125	60	250	225	145	125
125	60	300	275	195	150

Forma de pedido: GACH + W1*L1

How to order: GACH + W1*L1

GUÍA "V" GBGM V" DRIVER GBGM

Material: Bronce + grafito / Bronze + graphite
Dureza / Hardness: HB > 190

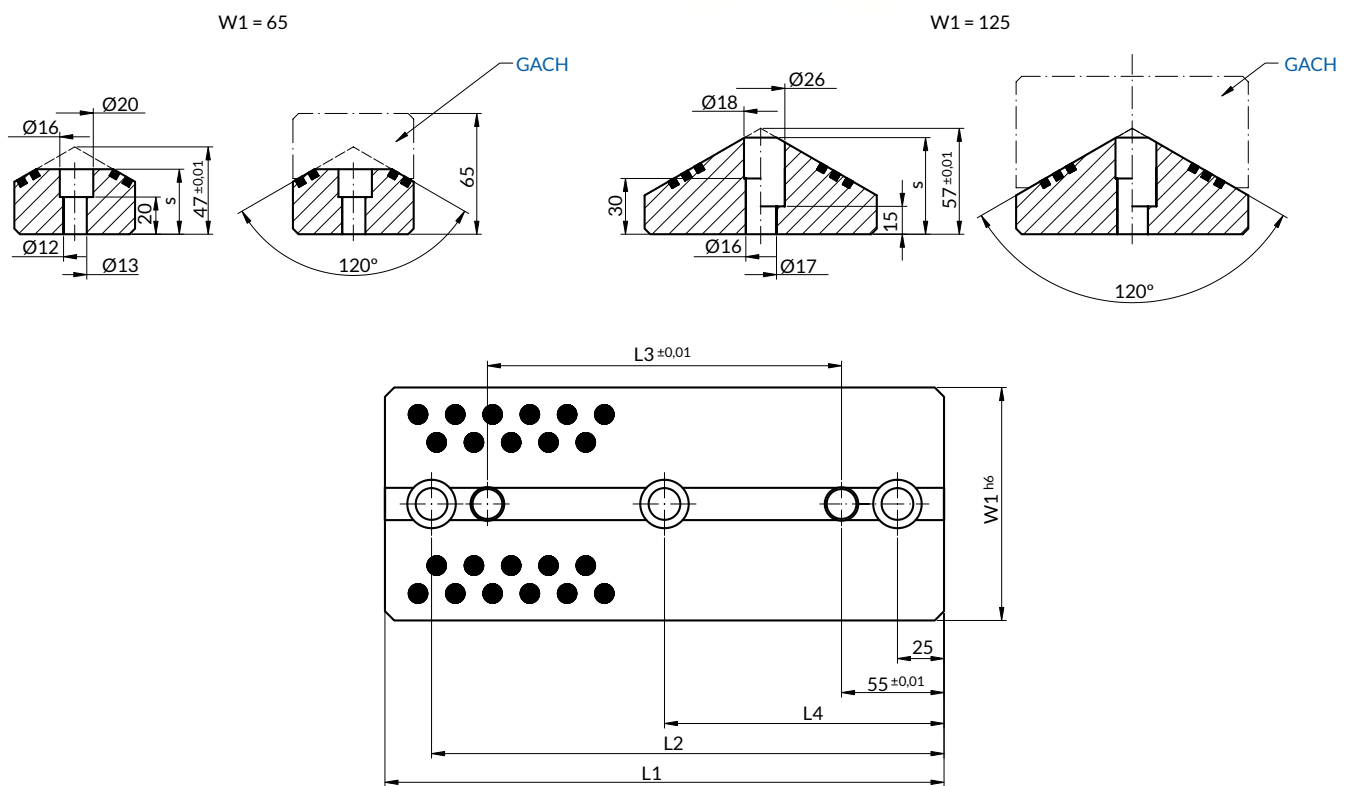

Norma / Standard: VDI 3357

W1	S	L1	L2	L3	L4
65	35	150	125	45	-
65	35	200	175	95	-
65	35	250	225	145	125
65	35	300	275	195	150
125	52	150	125	45	-
125	52	200	175	95	-
125	52	250	225	145	125
125	52	300	275	195	150

Forma de pedido: GBGM + W1*L1
How to order: GBGM + W1*L1

GUÍA "V" GBGH
"V" DRIVER GBGH

Material: Bronce + grafito / Bronze + graphite
 Dureza / Hardness: HB > 190

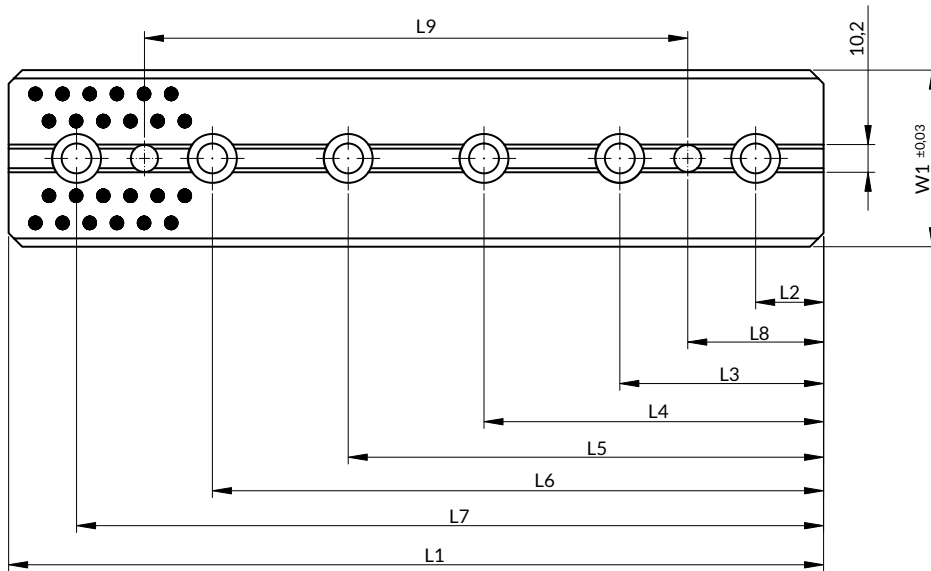
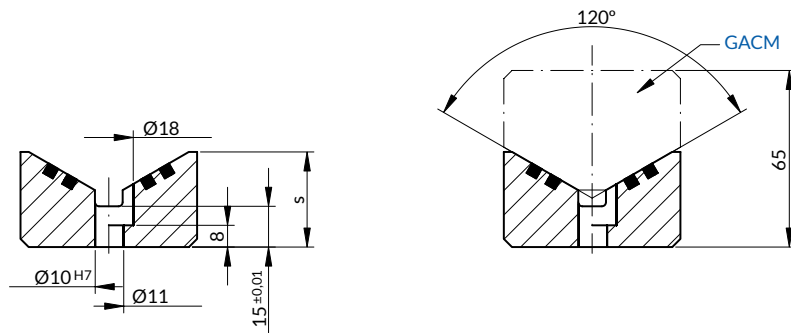

W1	S	L1	L2	L3	L4	L5	L6	L7	L8	L9
65	35	100	20	80	-	-	-	-	40	20
65	35	150	25	75	125	-	-	-	50	50
65	35	200	25	75	125	175	-	-	50	100
65	35	250	25	75	125	175	225	-	50	150
65	35	300	25	75	125	175	225	275	50	200

Forma de pedido: GBGH + W1*L1
 How to order: GBGH + W1*L1

GUÍA "V" GACM "V" DRIVER GACM

Material: CK 45

Dureza en superficie de deslizamiento / Sliding surface hardness: 58-60 HRC

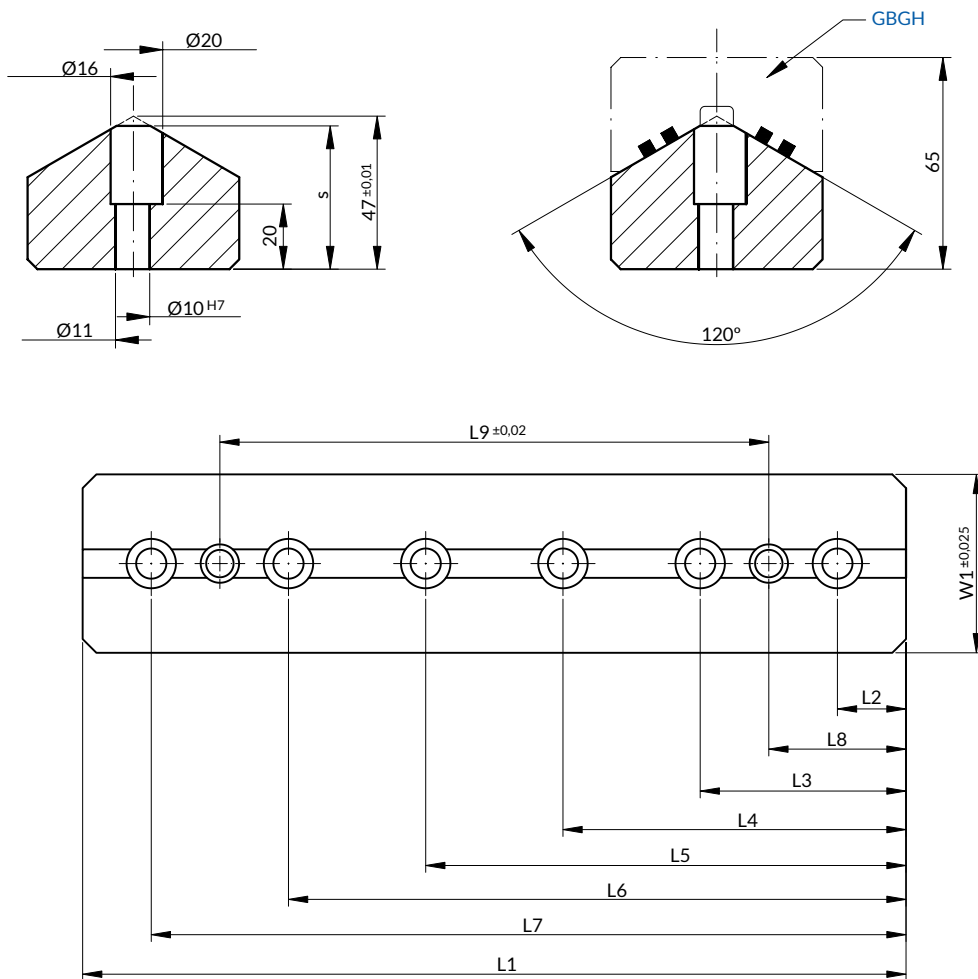

W1	S	L1	L2	L3	L4	L5	L6	L7	L8	L9
65	44	100	20	80	-	-	-	-	40	20
65	44	150	25	75	125	-	-	-	50	50
65	44	200	25	75	125	175	-	-	50	100
65	44	250	25	75	125	175	225	-	50	150
65	44	300	25	75	125	175	225	275	50	200

Forma de pedido: GACM + W1*L1

How to order: GACM + W1*L1

GUÍA CARRO GBGO - GACO

CAM WEAR PLATE GBGO - GACO

GBGO



Material: Bronce + grafito / Bronze + graphite
Dureza / Hardness: HB > 190

GACO



Material: 42CrMo4
Dureza / Hardness: 58-60 HRC

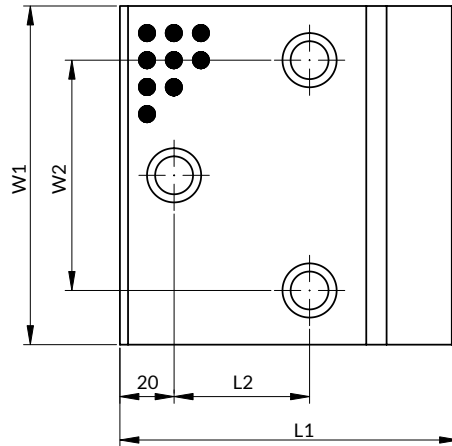
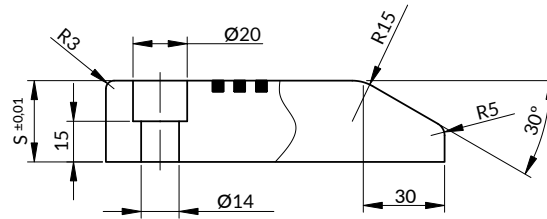

W1	S	L1	W2	L2	L3
100	30	125	60	50	132,8
125	30	125	85	50	132,8
160	30	125	120	50	132,8
100	45	150	60	45	127,9
125	45	150	85	45	127,9
160	45	150	120	45	127,9
100	60	170	60	45	127,9
125	60	170	85	45	127,9
160	60	170	120	45	127,9

Forma de pedido: G_O + W1*L1*S
How to order: G_O + W1*L1*S

GUÍA CARRO GBGW - GACW CAM WEAR PLATE GBGW - GACW

GBGW



Material: Bronce + grafito / Bronze + graphite
Dureza / Hardness: HB > 190

GACW



Material: 1.2379
Dureza / Hardness: 58-62 HRC

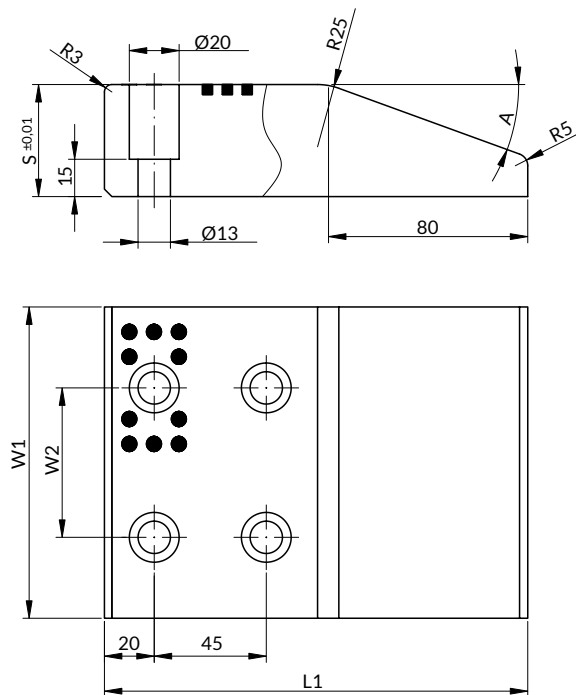

Norma / Standard: VDI 3357

W1	S	L1	W2	A
100	45	150	60	30°
125	45	150	85	30°
150	45	150	110	30°
100	45	170	60	20°
125	45	170	85	20°
150	45	170	110	20°
100	60	170	60	30°
125	60	170	85	30°
150	60	170	110	30°

Forma de pedido / How to order: GBGW + W1*L1*S
GACW + W1*L1*S

ELEMENTOS DE RECUPERACIÓN RECOVERY ELEMENTS



Los muelles, cilindros de nitrógeno y elastómeros son elementos elásticos de amortiguación y de recuperación, utilizados para determinadas aplicaciones en troqueles. Sometidos a la presión concreta, ejercen una fuerza determinada.

En este apartado podrás encontrar elementos elásticos que se adaptan a todo tipo de necesidades en función del espacio, la altura o la fuerza del troquel. La elección idónea de los elementos elásticos es la clave para conseguir el máximo rendimiento y duración de éstos.

Además, podemos diseñar y fabricar productos especiales, para dar solución a necesidades específicas de producción.

Springs, nitrogen gas springs and elastomers are shock absorbing and recovery elastic elements that are used in specific tasks with dies. Once submitted to high pressure they exert a certain force.

In this section you will find elastic tools that adapt to all types of dies in terms of space, height, or force of the die. Choosing the adequate elastic element is key to achieve the maximum performance and longevity of them.

In addition, we can design and manufacture special products, according to special designs and particular production needs.

ELEMENTOS DE RECUPERACIÓN

RECOVERY ELEMENTS

ÍNDICE INDEX

228

**MUELLE RECTANGULAR CARGA
EXTRA-LIGERA RNVL**
EXTRA-LIGHT LOAD
RECTANGULAR SPRINGS RNVL



-

231

**MUELLE RECTANGULAR CARGA
LIGERA RNV**
LIGHT LOAD RECTANGULAR
SPRINGS RNV



ISO 10243

234

**MUELLE RECTANGULAR CARGA
MEDIA RNB**
MEDIUM LOAD RECTANGULAR
SPRINGS RNB



ISO 10243

237

**MUELLE RECTANGULAR CARGA
FUERTE RNR**
HEAVY LOAD RECTANGULAR
SPRINGS RNR



ISO 10243

240

**MUELLE RECTANGULAR CARGA
EXTRA-FUERTE RNG**
EXTRA-HEAVY LOAD
RECTANGULAR SPRINGS RNG



ISO 10243

243

**MUELLE RECTANGULAR CARGA
ULTRA-FUERTE RNA**
ULTRA-HEAVY LOAD
RECTANGULAR SPRINGS RNA



-

246

**MUELLE RECTANGULAR CARGA
SÚPER-FUERTE RNT**
SUPER-STRONG LOAD
RECTANGULAR SPRINGS RNT



-

247

**MUELLE RECTANGULAR CARGA
HÍPER-FUERTE RNW**
HYPER-STRONG LOAD
RECTANGULAR SPRINGS RNW



-

248

**MUELLE REDONDO CARGA
LIGERA RNTV**
LIGHT LOAD ROUND SPRINGS
RNTV



-

249

**MUELLE REDONDO CARGA
MEDIA RNTB**
MEDIUM LOAD ROUND SPRINGS
RNTB



-

250

**MUELLE REDONDO CARGA
FUERTE RNTR**
HEAVY LOAD ROUND SPRINGS
RNTR



-

251

**MUELLE REDONDO NO PINTADO
CON LUBRICACIÓN ANTIÓXIDO
RNL**
NON PAINTED ROUND SPRINGS
WITH ANTI-RUST LUBRICANT RNL



-

254

**MUELLE REDONDO
COMPRESIÓN SIN EXTREMOS
REFRENTADOS RNL**
LONG SIZE ROUND SPRINGS
OPEN ENDS RNL



-

255

**MUELLE OVALADO CARGA
LIGERA ROB**
LIGHT LOAD OVAL SPRINGS ROB



US standard

258

**MUELLE OVALADO CARGA
MEDIA ROR**
MEDIUM LOAD OVAL SPRINGS
ROR



US standard

261

**MUELLE OVALADO CARGA
FUERTE ROG**
HEAVY LOAD OVAL SPRINGS ROG



US standard

264

MUELLE OVALADO CARGA EXTRA-FUERTE ROV
EXTRA-HEAVY LOAD OVAL SPRINGS **ROV**



US standard

267

ELASTÓMERO BARRA MACIZA ELAM
SOLID BAR ELASTOMER **ELAM**



-

267

ELASTÓMERO BARRA HUECA ELAH
HOLLOW BAR ELASTOMER **ELAH**



-

268

DESPEGADORES DE ELASTÓMERO DESR
STRIPPER BAR **DESR**



-

269

DESPEGADORES DE ELASTÓMERO DESC
STRIPPER BAR **DESC**



-

270

DESPEGADOR DEST
STRIPPER **DEST**



DIN 9835

271

GUÍA PARA ELASTÓMERO ELAG
GUIDE BOLT FOR ELASTOMER **ELAG**



-

272

POSICIONADOR DE BOLA PB
BALL PLUNGER **PB**



-

273

EXPULSOR DE MUELLE EMA
SPRING PLUNGER **EMA**



-

274

EXPULSOR DE MUELLE EMB
SPRING PLUNGER **EMB**



-

275

EXPULSOR DE GAS NE-NG
GAS EJECTOR **NE-NG**



VDI

283

MINI CILINDRO M
MINI GAS SPRING **M**



VDI

290

CILINDRO RV
GAS SPRING **RV**



ISO, VDI

306

CILINDRO SC
GAS SPRING **SC**



ISO, VDI

317

BRIDA DE AMARRE FB
FLANGE MOUNT **FB**



ISO 11901-2, VDI 3003

318

BRIDA DE AMARRE FBA
FLANGE MOUNT **FBA**



-

319

BRIDA DE AMARRE FBB
FLANGE MOUNT FBB



320

BRIDA DE AMARRE FBD
FLANGE MOUNT FBD



321

BRIDA DE AMARRE FS2
FLANGE MOUNT FS2



ISO 11901-2, VDI 3003

322

BRIDA DE AMARRE FS2B
FLANGE MOUNT FS2B



VDI 3003

323

BRIDA DE AMARRE FS2A
FLANGE MOUNT FS2A



324

BRIDA DE AMARRE FS3
FLANGE MOUNT FS3



324

BRIDA DE AMARRE FCA
FLANGE MOUNT FCA



325

BRIDA DE AMARRE FC-FCC
FLANGE MOUNT FC-FCC



ISO 11901-2, VDI 3003

326

BRIDA DE AMARRE FC-FCC
FLANGE MOUNT FC-FCC



ISO 11901-2, VDI 3003

327

BRIDA DE AMARRE FCQ-FCQC
FLANGE MOUNT FCQ-FCQC



ISO 11901-2, VDI 3003

328

BRIDA DE AMARRE FT
FLANGE MOUNT FT



329

BRIDA DE AMARRE FTP
FLANGE MOUNT FTP



330

BRIDA DE AMARRE FSA
FLANGE MOUNT FSA



ISO 11901-2, VDI 3003

331

BRIDA DE AMARRE FSB-FSC-FSD
FLANGE MOUNT FSB-FSC-FSD



VDI 3003

332

BRIDA DE AMARRE FSE
FLANGE MOUNT FSE



333

BRIDA DE AMARRE R
FLANGE MOUNT R



334

BRIDA DE AMARRE GM
FLANGE MOUNT GM



334

BRIDA DE AMARRE DM
FLANGE MOUNT DM



335

CILINDROS CONECTADOS LINKED SYSTEM
CONNECTED GAS SPRINGS LINKED SYSTEM



336

CILINDROS CONECTADOS EASY MANIFOLD
CONNECTED GAS SPRINGS EASY MANIFOLD



337

PROTECCIÓN
PROTECTION



338

RASCADOR SECUNDARIO SW
SECONDARY WIPER SW



339

SEGURIDAD
SAFETY



MUELLE RECTANGULAR CARGA EXTRA-LIGERA RNVL

EXTRA-LIGHT LOAD RECTANGULAR SPRINGS RNVL

STOCK

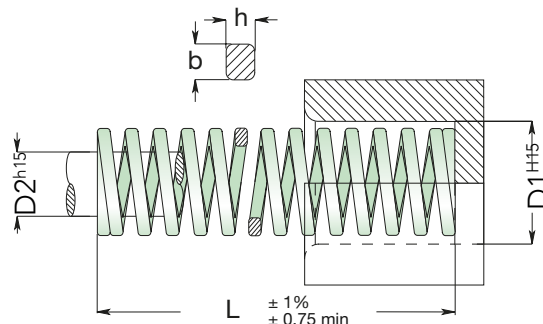

RNVL

D1	D2	L	R	A	B	C	D	E				
Diámetro del alojamiento Hole diameter	Diámetro de la guía Spring inside diameter	Longitud libre Free length	Constante elástica ± 10 Spring constant ± 10	30% L	40% L	45% L	50% L	aprox. no usar approx. do not use				
b x h			$\pm 10\%$	+ 3.000.000	~ 1.500.000	300 - 500.00	100 - 200.00					
mm	mm	mm	N/mm	mm N	mm N	mm N	mm N	mm				
10	5	25	8,5	7,5	63,8	10,0	85,0	11,3	96,1	12,5	106,3	14,1
		32	6,5	9,6	62,4	12,8	83,2	14,4	93,6	16,0	104,0	18,5
		38	5,5	11,4	62,7	15,2	83,6	17,1	94,1	19,0	104,5	22,5
		44	4,8	13,2	63,4	17,6	84,6	19,8	95,0	22,0	105,6	23,2
		51	4,2	15,3	64,3	20,4	85,7	23,0	96,6	25,5	107,1	27,5
		64	3,3	19,2	63,4	25,6	84,5	28,8	95,0	32,0	105,6	34,0
		76	2,7	22,8	61,6	30,4	82,1	34,2	92,3	38,0	102,6	40,4
1,65 x 1,0		305	0,7	91,5	59,5	122,0	79,3	137,3	89,2	152,5	99,1	172,7
12,5	6,3	25	16,0	7,5	120,0	10,0	160,0	11,3	180,8	12,5	200,0	13,6
		32	12,2	9,6	117,1	12,8	156,2	14,4	175,7	16,0	195,2	17,9
		38	10,3	11,4	117,4	15,2	156,6	17,1	176,1	19,0	195,7	21,9
		44	8,7	13,2	114,8	17,6	153,1	19,8	172,3	22,2	191,4	26,4
		51	7,5	15,3	114,8	20,4	153,0	20,0	172,5	25,5	191,3	29,6
		64	5,8	19,2	111,4	25,6	148,5	28,8	167,0	32,0	185,6	37,1
		76	4,7	22,8	107,2	30,4	142,9	34,2	160,7	38,0	178,6	44,9
		89	4,1	26,7	109,5	35,6	146,0	40,1	164,4	44,5	182,5	53,2
2,3 x 1,3		305	1,3	91,5	114,4	122,0	152,5	137,3	171,6	152,5	190,6	186,6
16	8	25	20,2	7,5	151,5	10,0	202,0	11,3	228,3	12,5	252,5	14,0
		32	16,0	9,6	153,6	12,8	204,8	14,4	230,4	16,0	256,0	18,7
		38	12,3	11,4	140,2	15,2	187,0	17,1	210,3	19,0	233,7	22,0
		44	10,6	13,2	139,9	17,6	186,6	19,8	209,9	22,0	233,2	26,1
		51	8,9	15,3	136,2	20,4	181,6	23,0	204,7	25,5	227,0	30,4
		64	7,0	19,2	134,4	25,6	179,2	28,8	201,6	32,0	224,0	38,8
		76	5,8	22,8	132,2	30,4	176,3	34,2	198,4	38,0	220,4	46,4
		89	4,8	26,7	128,2	35,6	170,9	40,1	192,5	44,5	231,6	54,2
		102	4,1	30,8	125,5	40,8	167,3	45,9	188,2	51,0	209,1	62,4
3,05 x 1,5		305	1,5	91,5	137,3	122,0	183,0	137,3	206,0	152,5	228,8	190,2

Continúa en la siguiente página...
Continue next page...

Forma de pedido: RNVL + D1 * L
How to order: RNVL + D1 * L

RNVL

D1	D2	L	R	A		B		C		D		E
Diámetro del alojamiento Hole diameter	Diámetro de la guía Spring inside diameter	Longitud libre Free length	Constante elástica ±10 Spring constant ±10		30% L		40% L		45% L		50% L	 aprox. no usar aprox. do not use
b x h			±10%	+ 3.000.000		~ 1.500.000		300 - 500.00		100 - 200.00		
mm	mm	mm	N/mm	mm	N	mm	N	mm	N	mm	N	mm
20	10	25	29,4	7,5	220,5	10,0	294,0	11,3	332,2	12,5	367,5	13,9
		32	22,6	9,6	217,0	12,8	289,3	14,4	325,4	16,0	361,6	18,2
		38	18,6	11,4	212,0	15,2	282,7	17,1	318,1	19,0	353,4	22,0
		44	15,7	13,2	207,2	17,6	276,3	19,8	310,9	22,0	345,4	25,8
		51	13,7	15,3	209,6	20,4	279,5	23,0	315,1	25,5	349,4	30,3
		64	11,3	19,2	217,0	25,6	289,3	28,8	325,4	32,0	361,6	38,9
		76	9,8	22,8	223,4	30,4	297,9	34,2	335,2	38,0	372,4	47,0
		89	8,3	26,7	221,6	35,6	295,5	40,1	332,8	44,5	369,4	55,7
		102	7,4	30,6	226,4	40,8	301,9	45,9	339,7	51,0	377,4	64,2
		115	6,4	34,5	220,8	46,0	294,4	51,8	331,5	57,5	368,0	72,9
		127	5,9	38,1	224,8	50,8	299,7	57,2	337,5	63,5	374,7	80,7
		139	5,4	41,7	225,2	55,6	300,2	62,6	338,0	69,5	375,3	88,4
152	4,9	45,6	223,4	60,8	297,9	68,4	335,2	76,0	372,4	96,7		
3,9 x 1,7		305	2,5	91,5	228,8	122,0	305,0	137,3	343,3	152,5	381,3	196,0
25	12,5	25	53,9	7,5	404,3	10,0	539,0	11,3	609,1	12,5	673,8	12,9
		32	42,2	9,6	405,1	12,8	540,2	14,4	607,7	16,0	675,2	17,2
		38	35,8	11,4	408,1	15,2	544,2	17,1	612,2	19,0	680,2	20,7
		44	31,4	13,2	414,5	17,6	552,6	19,8	621,7	22,0	690,8	24,4
		51	27,0	15,3	413,1	20,4	550,8	23,0	621,0	25,5	688,5	28,5
		64	21,6	19,2	414,7	25,6	553,0	28,8	622,1	32,0	691,2	36,5
		76	18,1	22,8	412,7	30,4	550,2	34,2	619,0	38,0	687,8	43,9
		89	15,2	26,7	405,8	35,6	541,1	40,1	609,5	44,5	676,4	51,4
		102	13,2	30,6	403,9	40,8	538,5	45,9	605,9	51,0	673,2	59,3
		115	11,8	34,5	407,1	46,0	542,8	51,8	611,2	57,5	678,5	67,2
		107	10,6	38,1	403,9	50,8	538,5	57,2	606,3	63,5	673,1	74,4
		139	9,6	41,7	400,3	55,6	533,8	62,6	601,0	69,5	667,2	81,6
		152	8,8	45,6	401,3	60,8	535,0	68,4	601,9	76,0	668,8	89,5
		178	7,6	53,4	405,8	71,2	541,1	80,1	608,8	89,0	676,4	105,0
203	6,7	60,9	408,0	81,2	544,0	91,4	612,4	101,5	680,1	121,0		
5,4 x 2,2		305	4,4	91,5	402,6	122,0	563,8	137,3	604,1	152,5	671,0	182,0
32	16	38	43,1	11,4	491,3	15,2	655,1	17,1	737,0	19,0	818,9	19,9
		44	37,3	13,2	492,4	17,6	656,5	19,8	738,5	22,0	820,6	23,5
		51	32,4	15,3	495,7	20,4	661,0	23,0	745,2	25,5	826,6	27,6
		64	25,5	19,2	489,6	25,6	652,8	28,8	734,4	32,0	816,0	35,2
		76	21,6	22,8	492,5	30,4	656,6	34,2	738,7	38,0	820,8	42,4
		89	18,1	26,7	483,3	35,6	644,4	40,1	725,8	44,5	805,5	50,0
		102	15,7	30,6	480,4	40,8	640,6	45,9	720,6	51,0	800,7	57,6
		115	14,2	34,5	489,9	46,0	653,2	51,8	735,6	57,5	816,5	65,5
		127	12,7	38,1	483,9	50,8	645,2	57,2	726,4	63,5	806,5	72,5
139	11,6	41,7	483,7	55,6	645,0	62,2	726,2	69,5	806,2	79,4		





Continúa en la siguiente página...
Continue next page...

Forma de pedido: RNVL + D1 * L
How to order: RNVL + D1 * L

MUELLE RECTANGULAR CARGA EXTRA-LIGERA RNVL

EXTRA-LIGHT LOAD RECTANGULAR SPRINGS RNVL

RNVL

D1	D2	L	R	A		B		C		D		E
Diámetro del alojamiento Hole diameter	Diámetro de la guía Spring inside diameter	Longitud libre Free length	Constante elástica ±10 Spring constant ±10		30% L		40% L		45% L		50% L	
b x h			±10%	+ 3.000.000		~ 1.500.000		300 - 500.00		100 - 200.00		
mm		mm	N/mm	mm	N	mm	N	mm	N	mm	N	mm
32	16	152	10,6	45,6	483,4	60,8	644,5	68,4	725,0	76,0	805,6	87,3
		178	9,0	53,4	480,6	71,2	640,8	80,1	720,9	89,0	801,0	103,0
		203	7,8	60,9	475,0	81,2	633,4	91,4	712,9	101,5	791,7	118,0
		254	6,4	76,2	487,7	101,6	650,2	114,3	731,5	127,0	812,8	148,0
6,5 x 2,6		305	5,3	91,5	485,0	122,0	646,6	137,3	727,7	152,5	808,3	178,0
40	20	51	48,1	15,3	736	20,4	981	23,0	1106	25,5	1227	28,0
		64	39,2	19,2	753	25,6	1004	28,8	1129	32,0	1254	36,2
		76	33,3	22,8	759	30,4	1012	34,2	1139	38,0	1265	43,7
		89	28,4	26,7	758	35,6	1011	40,1	1139	44,5	1264	51,7
		102	24,5	30,6	750	40,8	1000	45,9	1125	51,0	1250	59,8
		115	22,1	34,5	762	46,0	1017	51,8	1145	57,5	1271	67,9
		127	19,6	38,1	747	50,8	996	57,2	1121	63,5	1245	75,2
		139	17,7	41,7	738	55,6	984	62,6	1108	69,5	1230	82,4
		152	16,2	45,6	739	60,8	985	68,4	1108	76,0	1231	90,6
		178	13,7	53,4	732	71,2	975	80,1	1097	89,0	1219	106,0
		203	12,3	60,9	749	81,2	999	91,4	1124	101,5	1248	122,0
8,0 x 3,4		305	8,3	91,5	759	122,0	1013	137,3	1140	152,5	1266	185,0
50	25	64	86,3	19,2	1657	25,6	2209	28,8	2485	32,0	2762	35,1
		76	70,6	22,8	1610	30,4	2146	34,2	2415	38,0	2683	42,2
		89	59,8	26,7	1597	35,6	2129	40,1	2398	44,5	2661	50,3
		102	52,0	30,6	1591	40,8	2122	45,9	2387	51,0	2652	58,4
		115	46,1	34,5	1590	46,0	2121	51,8	2388	57,5	2651	66,1
		127	42,2	38,1	1608	50,8	2144	57,2	2414	63,5	2680	73,8
		139	38,2	41,7	1593	55,6	2124	62,6	2391	69,5	2655	80,9
		152	34,3	45,6	1564	60,8	2085	68,4	2346	76,0	2607	89,0
		178	29,4	53,4	1570	71,2	2093	80,1	2355	89,0	2617	105,0
		203	25,5	60,9	1553	81,2	2071	91,4	2331	101,5	2588	121,0
10,5 x 4,1		305	17,2	91,5	1574	122,0	2098	137,3	2362	152,5	2623	184,0
63	38	76	57,8	22,8	1318	30,4	1757	34,2	1977	38,0	2196	47,3
		89	51,4	26,7	1372	35,6	1830	40,1	2061	44,5	2287	54,9
		102	44,4	30,6	1359	40,8	1812	45,9	2038	51,0	2264	64,1
		115	38,0	34,5	1311	46,0	1748	51,8	1968	57,5	2185	75,6
		127	33,2	38,1	1265	50,8	1687	57,2	1899	63,5	2108	82,6
		152	27,4	45,6	1249	60,8	1666	68,4	1874	76,0	2082	99,8
		178	24,0	53,4	1282	71,2	1709	80,1	1922	89,0	2136	118,4
		203	21,0	60,9	1279	81,2	1705	91,4	1919	101,5	2132	135,9
11 x 4,9		305	13,6	91,5	1244	122,0	1659	137,3	1867	152,5	2074	208,6

Forma de pedido: RNVL + D1 * L
How to order: RNVL + D1 * L

MUELLE RECTANGULAR CARGA LIGERA RNV

LIGHT LOAD RECTANGULAR SPRINGS RNV

STOCK

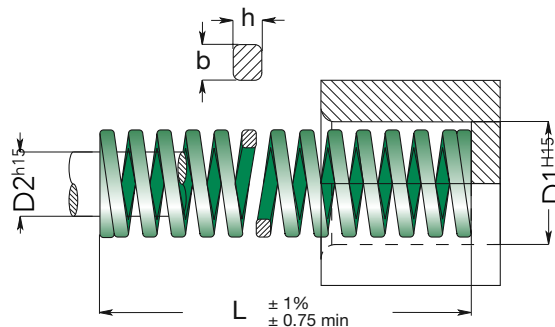

RNV

Norma / Standard: ISO 10243

D1	D2	L	R	A	B	C	D	E				
Diámetro del alojamiento Hole diameter	Diámetro de la guía Spring inside diameter	Longitud libre Free length	Constante elástica ± 10 Spring constant ± 10	25% L	30% L	35% L	40% L	aprox. no usar aprox. do not use				
b x h		$\pm 10\%$	$+ 3.000.000$	$- 1.500.000$	$300 - 500.00$	$100 - 200.00$						
mm	mm	mm	N/mm	mm	N	mm	N	mm				
10	5	25	11,0	6,3	69,3	7,5	82,5	8,8	96,8	10,0	110,0	13,5
		32	8,5	8,0	68,0	9,6	81,6	11,2	95,2	12,8	108,8	17,5
		38	6,8	9,5	64,6	11,4	77,5	13,3	90,4	15,2	103,4	20,8
		44	6,0	11,0	66,0	13,2	79,2	15,4	92,4	17,6	105,6	23,9
		51	5,0	12,8	64,0	15,3	76,5	17,9	89,5	20,4	102,0	28,9
		64	4,1	16,0	65,5	19,2	78,7	22,4	91,8	25,6	105,0	36,1
		76	3,6	19,0	68,4	22,8	82,1	26,6	95,8	30,4	109,4	43,2
1,7 x 1,1		305	0,9	76,3	68,7	91,5	82,4	106,8	96,1	122,0	109,8	178,0
12,5	6,3	25	6,3	6,3	132,3	7,5	157,5	8,8	184,8	10,0	210,0	13,2
		32	8,0	8,0	131,2	9,6	157,4	11,2	183,7	12,8	209,9	18,0
		38	9,5	9,5	129,2	11,4	155,0	13,3	180,9	15,2	206,7	21,0
		44	11,0	11,0	133,1	13,2	159,7	15,4	186,3	17,6	213,0	24,0
		51	12,8	12,8	131,8	15,3	157,6	17,9	184,4	20,4	210,1	28,7
		64	16,0	16,0	121,6	19,2	145,9	22,4	170,2	25,6	194,6	35,8
		76	19,0	19,0	119,7	22,8	143,6	26,6	167,6	30,4	191,5	42,7
		89	22,3	22,3	120,4	26,7	144,2	31,2	168,5	35,6	192,2	50,4
2,4 x 1,4		305	76,3	76,3	122,1	91,5	146,4	106,8	170,9	122,0	195,2	172,0
16	8	25	6,3	6,3	182,7	7,5	217,5	8,8	255,2	10,0	290,0	12,6
		32	8,0	8,0	183,2	9,6	219,8	11,2	256,5	12,8	293,1	16,4
		38	9,5	9,5	183,4	11,4	220,0	13,3	256,7	15,2	293,4	19,7
		44	11,0	11,0	188,1	13,2	225,7	15,4	263,3	17,6	301,0	22,5
		51	12,8	12,8	179,2	15,3	214,2	17,9	250,6	20,4	285,6	26,3
		64	16,0	16,0	171,2	19,2	205,4	22,4	239,7	25,6	273,9	33,3
		76	19,0	19,0	171,0	22,8	205,2	26,6	239,4	30,4	273,6	40,2
		89	22,3	22,3	162,8	26,7	194,9	31,2	227,8	35,6	259,9	47,6
		102	25,5	25,5	173,4	30,6	208,1	35,7	242,8	40,8	277,4	55,4
3,2 x 1,5		305	76,3	76,3	175,5	91,5	210,5	106,8	245,6	122,0	280,6	165,0





Continúa en la siguiente página...
Continue next page...

Forma de pedido: RNV + D1 * L
How to order: RNV + D1 * L

MUELLE RECTANGULAR CARGA LIGERA RNV

LIGHT LOAD RECTANGULAR SPRINGS RNV







RNV

D1	D2	L	R	A		B		C		D		E
Diámetro del alojamiento Hole diameter	Diámetro de la guía Spring inside diameter	Longitud libre Free length	Constante elástica ±10 Spring constant ±10		25% L		30% L		35% L		40% L	 aprox. no usar aprox. do not use
b x h		±10%	+ 3.000.000	~ 1.500.000		300 - 500.00		100 - 200.00				
mm	mm	mm	N/mm	mm	N	mm	N	mm	N	mm	N	mm
20	10	25	55,8	6,3	351,5	7,5	418,5	8,8	491,0	10,0	558,0	12,1
		32	45,0	8,0	360,0	9,6	432,0	11,2	504,0	12,8	576,0	15,3
		38	36,0	9,5	342,0	11,4	410,4	13,3	478,8	15,2	547,2	18,9
		44	30,0	11,0	330,0	13,2	396,0	15,4	462,0	17,6	528,0	21,5
		51	24,5	12,8	313,6	15,3	374,9	17,9	438,6	20,4	499,8	25,0
		64	19,2	16,0	307,2	19,2	368,6	22,4	430,1	25,6	491,5	31,1
		76	16,0	19,0	304,0	22,8	364,8	26,6	425,6	30,4	486,4	37,3
		89	14,0	22,3	312,2	26,7	373,8	31,2	436,8	35,6	498,4	44,5
		102	12,0	25,5	306,0	30,6	367,2	35,7	428,4	40,8	489,6	51,1
		115	10,9	28,8	313,9	34,5	376,1	40,3	439,3	46,0	501,4	58,2
		127	9,5	31,8	302,1	38,1	362,0	44,5	422,8	50,8	482,6	64,9
		139	8,4	34,8	282,3	41,7	350,3	48,7	409,1	55,6	467,0	71,5
		152	7,5	38,0	285,0	45,6	342,0	53,2	399,0	60,8	456,0	78,8
178	7,1	44,5	316,0	53,4	379,1	62,3	442,3	71,2	505,5	89,0		
4,0 x 2,1	305	4,0	76,3	305,2	91,5	366,0	106,8	427,2	122,0	488,0	157,0	
25	12,5	25	105,0	6,3	661,5	7,5	787,5	8,8	924,0	10,0	1050,0	11,9
		32	80,3	8,0	642,4	9,6	770,9	11,2	899,4	12,8	1027,8	16,0
		38	62,0	9,5	589,0	11,4	706,8	13,3	824,6	15,2	942,4	18,3
		44	52,9	11,0	581,9	13,2	698,3	15,4	814,7	17,6	931,0	21,4
		51	44,0	12,8	563,2	15,3	673,2	17,9	787,6	20,4	897,6	24,9
		64	35,2	16,0	563,2	19,2	675,8	22,4	788,5	25,6	901,1	31,4
		76	28,0	19,0	532,0	22,8	638,4	26,6	744,8	30,4	851,2	37,5
		89	24,0	22,3	535,2	26,7	640,8	31,2	748,8	35,6	854,4	43,5
		102	21,1	25,5	538,1	30,6	645,7	35,7	753,3	40,8	860,9	51,1
		115	18,7	28,8	538,6	34,5	645,2	40,3	753,6	46,0	860,2	58,1
		127	16,7	31,8	531,1	38,1	636,3	44,5	743,2	50,8	848,4	64,1
		139	15,3	34,8	532,4	41,7	638,0	48,7	745,1	55,6	850,7	70,4
		152	14,0	38,0	532,0	45,6	638,4	53,2	744,8	60,8	851,2	77,1
178	12,5	44,5	556,3	53,4	667,5	62,3	778,8	71,2	890,0	93,1		
203	10,4	50,8	528,3	60,9	633,4	71,1	739,4	81,2	844,5	103,0		
5,4 x 2,7	305	7,0	76,3	534,1	91,5	640,5	106,8	747,6	122,0	854,0	156,0	
32	16	38	98,0	9,5	931	11,4	1117	13,3	1303	15,2	1490	18,3
		44	79,5	11,0	875	13,2	1049	15,4	1224	17,6	1399	21,5
		51	67,0	12,8	858	15,3	1025	17,9	1199	20,4	1367	25,5
		64	53,0	16,0	848	19,2	1018	22,4	1187	25,6	1357	31,9
		76	44,0	19,0	836	22,8	1003	26,6	1170	30,4	1338	38,6
		89	37,2	22,3	830	26,7	993	31,2	1161	35,6	1324	46,5
		102	32,0	25,5	816	30,6	979	35,7	1142	40,8	1306	53,2
		115	29,0	28,8	835	34,5	1001	40,3	1169	46,0	1334	60,0
		127	25,0	31,8	795	38,1	953	44,5	1113	50,8	1270	66,7
139	23,0	34,8	800	41,7	959	48,7	1120	55,6	1279	71,8		

Continúa en la siguiente página...
Continue next page...

Forma de pedido: RNV + D1 * L
How to order: RNV + D1 * L

RNV

D1	D2	L	R		A		B		C		D		E
Diámetro del alojamiento Hole diameter	Diámetro de la guía Spring inside diameter	Longitud libre Free length	Constante elástica ±10 Spring constant ±10		25% L		30% L		35% L		40% L		 aprox. no usar approx. do not use
b x h			±10%	+ 3.000.000		~ 1.500.000		300 - 500.00		100 - 200.00			
mm	mm	mm	N/mm	mm	N	mm	N	mm	N	mm	N	mm	
32	16	152	21,5	38,0	817	45,6	980	53,2	1144	60,8	1307	78,5	
		178	18,2	44,5	810	53,4	972	62,3	1134	71,2	1296	94,4	
		203	15,8	50,8	803	60,9	962	71,1	1123	81,2	1283	107,0	
		254	12,5	63,5	794	76,2	953	88,9	1111	102,0	1275	136,0	
6,8 x 3,3		305	10,3	76,3	786	91,5	942	106,8	1100	122,0	1257	163,0	
40	20	51	92,0	12,8	1178	15,3	1408	17,9	1647	20,4	1877	25,5	
		64	73,0	16,0	1168	19,2	1402	22,4	1635	25,6	1869	31,4	
		76	63,0	19,0	1197	22,8	1436	26,6	1676	30,4	1915	37,8	
		89	51,0	22,3	1137	26,7	1362	31,2	1591	35,6	1816	44,3	
		102	43,0	25,5	1148	30,6	1377	35,7	1607	40,8	1836	50,7	
		115	39,6	28,8	1140	34,5	1366	40,3	1596	46,0	1822	58,1	
		127	37,0	31,8	1145	38,1	1375	44,5	1602	50,8	1829	64,6	
		139	32,0	34,8	1114	41,7	1334	48,7	1558	55,6	1779	70,1	
		152	28,0	38,0	1064	45,6	1277	53,2	1490	60,8	1702	76,6	
		178	25,2	44,5	1121	53,4	1346	62,3	1570	71,2	1794	90,4	
203	22,7	50,8	1107	60,9	1328	71,1	1550	81,2	1770	102,0			
254	17,0	63,5	1080	76,2	1295	88,9	1511	102,0	1734	129,0			
8,1 x 4,0		305	14,8	76,3	1129	91,5	1354	106,8	1581	122,0	1806	156,0	
50	25	64	156,0	16,0	2496	19,2	2995	22,4	3494	25,6	3994	31,0	
		76	125,0	19,0	2375	22,8	2850	26,6	3325	30,4	3800	37,2	
		89	109,0	22,3	2431	26,7	2910	31,2	3401	35,6	3880	43,6	
		102	94,0	25,5	2397	30,6	1876	35,7	3356	40,8	3535	50,3	
		115	81,0	28,8	2333	34,5	2795	40,3	3264	46,0	3726	58,1	
		127	71,0	31,8	2258	38,1	2705	44,5	3160	50,8	3607	63,7	
		139	66,5	34,8	2314	41,7	2773	48,7	3239	55,6	3697	69,5	
		152	60,0	38,0	2280	45,6	2736	53,2	3192	60,8	3648	76,5	
		178	52,0	44,5	2314	53,4	2777	62,3	3240	71,2	3702	91,9	
		203	44,0	50,8	2235	60,9	2680	71,1	3128	81,2	3573	105,0	
254	35,0	63,5	2223	76,2	2667	88,9	3112	102,0	3570	131,0			
10,9 x 5,3		305	28,5	76,3	2175	91,5	2608	106,8	3044	122,0	3477	155,0	
63	38	76	189,0	19,0	3591	22,8	4309	26,6	5027	30,4	5746	36,5	
		89	158,0	22,3	3523	26,7	4219	31,2	4930	35,6	5625	43,4	
		102	131,0	25,5	3341	30,6	4009	35,7	4677	40,8	5345	49,7	
		115	116,0	28,8	3341	34,5	4002	40,3	4675	46,0	5336	55,6	
		127	103,0	31,8	3275	38,1	3924	44,5	4584	50,8	5232	62,7	
		152	84,3	38,0	3203	45,6	3844	53,2	4485	60,8	5125	77,1	
		178	71,5	44,5	3182	53,4	3818	62,3	4454	71,2	5091	92,2	
		203	61,7	50,8	3134	60,9	3758	71,1	4387	81,2	5010	103,0	
254	47,0	63,5	2985	76,2	3581	88,9	4178	102,0	1894	130,0			
11,0 x 7,8		305	38,2	76,3	2915	91,5	3495	106,8	4080	122,0	4660	157,0	

Forma de pedido: RNV + D1 * L
How to order: RNV + D1 * L

MUELLE RECTANGULAR CARGA MEDIA RNB

MEDIUM LOAD RECTANGULAR SPRINGS RNB

STOCK

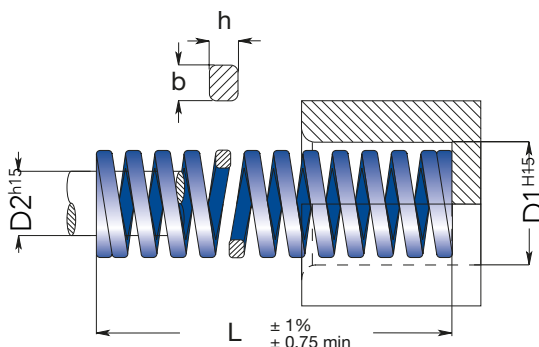

RNB





Norma / Standard: ISO 10243

D1	D2	L	R	A	B	C	D	E				
Diámetro del alojamiento Hole diameter	Diámetro de la guía Spring inside diameter	Longitud libre Free length	Constante elástica ±10 Spring constant ±10	25% L	30% L	33.75% L	37.5% L	aprox. no usar aprox. do not use				
b x h			±10%	+ 3.000.000	~ 1.500.000	300 - 500.00	100 - 200.00					
mm	mm	mm	N/mm	mm	N	mm	N	mm				
10	5	25	16,0	6,3	100,8	7,5	120,0	8,4	134,4	9,4	150,4	10,2
		32	13,0	8,0	104,0	9,6	124,8	10,8	140,4	12,0	156,0	14,2
		38	11,9	9,5	113,1	11,4	135,7	12,8	152,3	14,2	169,0	16,8
		44	10,3	11,0	113,3	13,2	136,0	14,9	153,5	16,5	170,0	19,4
		51	8,9	12,8	113,9	15,3	136,2	17,2	153,1	19,1	170,0	23,4
		64	7,5	16,0	120,0	19,2	144,0	21,6	162,0	24,0	180,0	28,2
		76	6,2	19,0	117,8	22,8	141,4	25,7	159,3	28,5	176,7	34,2
1,9 x 1,3		305	1,6	76,3	122,1	91,5	146,4	102,9	164,6	114,0	182,4	134,0
12,5	6,3	25	30,0	6,3	189,0	7,5	225,0	8,4	252,0	9,4	282,0	11,9
		32	24,8	8,0	198,4	9,6	238,1	10,8	267,8	12,0	297,6	16,2
		38	21,4	9,5	203,3	11,4	244,0	12,8	273,9	14,2	303,9	18,7
		44	18,0	11,0	198,0	13,2	237,6	14,9	268,2	16,5	297,0	21,3
		51	15,5	12,8	198,4	15,3	237,2	17,2	266,6	19,1	296,1	25,6
		64	12,1	16,0	193,6	19,2	232,3	21,6	261,4	24,0	290,4	32,4
		76	10,2	19,0	193,8	22,8	232,6	25,7	262,1	28,5	290,7	39,0
		89	8,4	22,3	187,3	26,7	224,3	30,0	252,0	33,3	279,7	45,9
2,5 x 1,5		305	2,4	76,3	183,1	91,5	219,6	102,9	247,0	114,0	273,6	153,0
16	8	25	49,4	6,3	311,2	7,5	370,5	8,4	415,0	9,4	464,4	10,5
		32	38,5	8,0	308,0	9,6	369,6	10,8	415,8	12,0	462,0	13,2
		38	33,9	9,5	322,1	11,4	386,5	12,8	433,9	14,2	481,4	17,2
		44	30,0	11,0	330,0	13,2	396,0	14,9	447,0	16,5	495,0	19,4
		51	26,4	12,8	337,9	15,3	403,9	17,2	454,1	19,1	504,2	24,2
		64	20,5	16,0	328,0	19,2	393,6	21,6	442,8	24,0	492,0	29,2
		76	17,8	19,0	338,2	22,8	405,8	25,7	457,5	28,5	507,3	36,3
		89	15,2	22,3	339,0	26,7	405,8	30,0	456,0	33,3	506,2	41,7
		102	13,5	25,5	344,3	30,6	413,1	34,4	464,4	38,2	515,7	48,9
		115	11,8	28,8	339,8	34,5	407,1	38,8	457,8	43,1	508,6	53,1
3,2 x 2,0		305	4,3	76,3	328,1	91,5	393,5	102,9	442,5	114,0	490,2	142,0

Continúa en la siguiente página...
Continue next page...

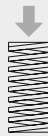
Forma de pedido: RNB + D1 * L
How to order: RNB + D1 * L







RNB

D1	D2	L	R	A	B	C	D	E				
Diámetro del alojamiento Hole diameter	Diámetro de la guía Spring inside diameter	Longitud libre Free length	Constante elástica ±10 Spring constant ±10	 25% L	 30% L	 33.75% L	 37.5% L	 <small>aprox. no usar aprox. do not use</small>				
b x h			±10%	+ 3.000.000	- 1.500.000	300 - 500.00	100 - 200.00					
mm	mm	mm	N/mm	mm N	mm N	mm N	mm N	mm				
20	10	25	98,0	6,3	617,4	7,5	735,0	8,4	823,2	9,4	921,2	10,5
		32	72,6	8,0	580,8	9,6	697,0	10,8	784,1	12,0	871,2	13,9
		38	56,0	9,5	532,0	11,4	638,4	12,8	716,8	14,2	795,2	16,6
		44	47,5	11,0	522,5	13,2	627,0	14,9	707,8	16,5	783,8	18,8
		51	41,7	12,8	533,8	15,3	638,0	17,2	717,2	19,1	796,5	23,1
		64	32,3	16,0	516,8	19,2	620,2	21,6	697,7	24,0	775,2	27,5
		76	25,1	19,0	476,9	22,8	572,3	25,7	645,1	28,5	715,4	33,8
		89	22,0	22,3	490,6	26,7	587,4	30,0	660,0	33,3	732,6	39,7
		102	19,8	25,5	504,9	30,6	605,9	34,4	681,1	38,2	756,4	47,3
		115	18,1	28,8	521,3	34,5	624,5	38,8	702,3	43,1	780,1	52,5
		127	16,6	31,8	527,9	38,1	632,5	42,9	712,1	47,6	790,2	56,9
		139	15,1	34,8	525,5	41,7	629,7	46,9	708,2	52,1	786,7	62,1
		152	13,2	38,0	501,6	45,6	601,9	51,3	677,2	57,0	752,4	67,6
4,1 x 2,4		305	6,1	76,3	465,4	91,5	558,2	102,9	627,7	114,0	695,4	143,0
25	12,5	25	157,0	6,3	989	7,5	1178	8,4	1319	9,4	1476	10,2
		32	118,0	8,0	944	9,6	1133	10,8	1274	12,0	1416	13,7
		38	93,0	9,5	884	11,4	1060	12,8	1190	14,2	1321	15,7
		44	80,8	11,0	889	13,2	1067	14,9	1204	16,5	1333	18,2
		51	68,6	12,8	878	15,3	1050	17,2	1180	19,1	1310	21,7
		64	53,0	16,0	848	19,2	1018	21,6	1145	24,0	1272	26,0
		76	43,2	19,0	821	22,8	985	25,7	1110	28,5	1231	32,3
		89	38,2	22,3	852	26,7	1020	30,0	1146	33,3	1272	38,0
		102	33,0	25,5	842	30,6	1010	34,4	1135	38,2	1261	43,0
		115	28,0	28,8	806	34,5	966	38,8	1086	43,1	1207	48,6
		127	25,9	31,8	824	38,1	987	42,9	1111	47,6	1233	53,7
		139	23,2	34,8	807	41,7	967	46,9	1088	52,1	1209	59,4
		152	20,8	38,0	790	45,6	948	51,3	1067	57,0	1186	63,8
178	17,8	44,5	792	53,4	951	60,1	1070	66,7	1187	76,6		
203	15,8	50,8	803	60,9	962	68,5	1082	76,1	1202	88,4		
5,4 x 3,3		305	10,2	76,3	778	91,5	933	102,9	1050	114,0	1163	135,0
32	16	38	185,0	9,5	1758	11,4	2109	12,8	2368	14,2	2627	16,3
		44	158,0	11,0	1738	13,2	2086	14,9	2354	16,5	2607	18,9
		51	134,0	12,8	1715	15,3	2050	17,2	2305	19,1	2559	23,1
		64	99,0	16,0	1584	19,2	1901	21,6	2138	24,0	2376	28,5
		76	80,5	19,0	1530	22,8	1835	25,7	2069	28,5	2294	34,2
		89	69,1	22,3	1541	26,7	1845	30,0	2073	33,3	2301	40,4
		102	58,8	25,5	1499	30,6	1799	34,4	2023	38,2	2246	48,0
		115	51,5	28,8	1483	34,5	1777	38,8	1998	43,1	2220	54,3
		127	44,8	31,8	1425	38,1	1707	42,9	1922	47,6	2132	59,2
		139	42,3	34,8	1472	41,7	1764	46,9	1984	52,1	2204	65,3
152	37,8	38,0	1436	45,6	1724	51,3	1939	57,0	2155	73,0		

Continúa en la siguiente página...
Continue next page...

Forma de pedido: RNB + D1 * L
How to order: RNB + D1 * L

RNB

D1	D2	L	R		A		B		C		D		E
Diámetro del alojamiento Hole diameter	Diámetro de la guía Spring inside diameter	Longitud libre Free length	Constante elástica ±10 Spring constant ±10		25% L		30% L		33.75% L		37.5% L		aprox. no usar aprox. do not use
b x h			±10%		+ 3.000.000		~ 1.500.000		300 - 500.00		100 - 200.00		
mm	mm	mm	N/mm	mm	N	mm	N	mm	N	mm	N	mm	mm
32	16	178	32,5	44,5	1446	53,4	1736	60,1	1953	66,7	2168		84,5
		203	28,9	50,8	1468	60,9	1760	68,5	1980	76,1	2199		96,9
		254	22,2	63,5	1410	76,2	1692	85,7	1903	95,2	2113		121,0
6,8 x 4,0		305	18,3	76,3	1396	91,5	1674	102,9	1883	114,0	2086		147,0
40	20	51	182,0	12,8	2330	15,3	2785	17,2	3130	19,1	3476		21,4
		64	140,0	16,0	2240	19,2	2688	21,6	3024	24,0	3360		26,8
		76	108,0	19,0	2052	22,8	2462	25,7	2776	28,5	3078		32,7
		89	90,7	22,3	2023	26,7	2422	30,0	2721	33,3	3020		39,0
		102	81,0	25,5	2066	30,6	2479	34,4	2786	38,2	3094		44,1
		115	71,8	28,8	2068	34,5	2477	38,8	2786	43,1	3095		50,6
		127	62,7	31,8	1994	38,1	2389	42,9	2690	47,6	2985		55,9
		139	57,5	34,8	2001	41,7	2398	46,9	2697	52,1	2996		61,8
		152	51,6	38,0	1961	45,6	2353	51,3	2647	57,0	2941		67,5
		178	44,1	44,5	1962	53,4	2355	60,1	2650	66,7	2941		77,2
		203	36,7	50,8	1864	60,9	2235	68,5	2514	76,1	2793		91,8
8,2 x 4,7		305	24,6	76,3	1877	91,5	2251	102,9	2531	114,0	2804		138,0
50	25	64	209,0	16,0	3344	19,2	4013	21,6	4514	24,0	5016		28,2
		76	168,0	19,0	3192	22,8	3830	25,7	4318	28,5	4788		34,9
		89	140,0	22,3	3122	26,7	3738	30,0	4200	33,3	4662		39,2
		102	119,0	25,5	3035	30,6	3641	34,4	4094	38,2	4546		47,3
		115	106,0	28,8	3053	34,5	3657	38,8	4113	43,1	4569		52,6
		127	97,0	31,8	3085	38,1	3696	42,9	4161	47,6	4617		59,8
		139	87,0	34,8	3028	41,7	3628	46,9	4080	52,1	4533		65,1
		152	80,0	38,0	3040	45,6	3648	51,3	4104	57,0	4560		70,8
		178	69,5	44,5	3093	53,4	3711	60,1	4177	66,7	4636		84,2
		203	59,8	50,8	3038	60,9	3642	68,5	4096	76,1	4551		96,5
		229	50,9	57,3	2917	68,7	3497	77,3	3935	85,8	4367		108,0
11,1 x 5,8		305	38,6	76,3	2945	91,5	3532	102,9	3972	114,0	4400		147,0
63	38	76	320,0	19,0	6080	22,8	7296	25,7	8224	28,5	9120		30,7
		89	260,0	22,3	5798	26,7	6942	30,0	7800	33,3	8658		36,5
		102	221,0	25,5	5636	30,6	6763	34,4	7602	38,2	8442		43,6
		115	187,0	28,8	5386	34,5	6452	38,8	7256	43,1	8060		48,9
		127	168,0	31,8	5342	38,1	6401	42,9	7207	47,6	7997		54,2
		152	136,0	38,0	5168	45,6	6202	51,3	6977	57,0	7752		65,7
		178	114,0	44,5	5073	53,4	6088	60,1	6851	66,7	7604		76,5
		203	100,0	50,8	5080	60,9	6090	68,5	6850	76,1	7610		88,0
		229	89,2	57,3	5111	68,7	6128	77,3	6895	85,8	7653		104,0
		254	78,4	63,5	4978	76,2	5974	85,7	6719	95,2	7464		112,0
11,5 x 9,1		305	64,7	76,3	4937	91,5	5920	102,9	6658	114,0	7376		134,0

Forma de pedido: RNB + D1 * L
How to order: RNB + D1 * L

MUELLE RECTANGULAR CARGA FUERTE RNR



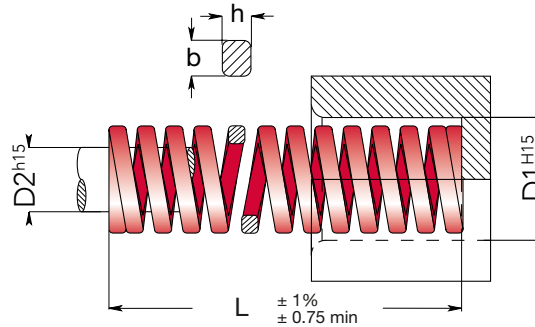

HEAVY LOAD RECTANGULAR SPRINGS RNR

STOCK



RNR

Norma / Standard: ISO 10243

D1	D2	L	R	A		B		C		D		E
Diámetro del alojamiento Hole diameter	Diámetro de la guía Spring inside diameter	Longitud libre Free length	Constante elástica ± 10 Spring constant ± 10		20% L		25% L		27.5% L		30% L	
b x h			$\pm 10\%$	+ 3.000.000		~ 1.500.000		300 - 500.00		100 - 200.00		
mm	mm	mm	N/mm	mm	N	mm	N	mm	N	mm	N	mm
10	5	25	23,0	5,0	115,0	6,3	144,9	6,9	158,7	7,5	172,5	9,2
		32	17,5	6,4	112,0	8,0	140,0	8,8	154,0	9,6	168,0	12,1
		38	14,8	7,6	112,5	9,5	140,6	10,5	155,4	11,4	168,7	13,2
		44	13,0	8,8	114,4	11,0	143,0	12,1	157,3	13,2	171,6	15,1
		51	11,2	10,2	114,2	12,8	143,4	14,0	156,8	15,3	171,4	19,5
		64	9,2	12,8	117,8	16,0	147,2	17,6	161,9	19,2	176,6	21,8
		76	7,5	15,2	114,0	19,0	142,5	20,9	156,8	22,8	171,0	27,9
1,9 x 1,5		305	1,9	61,0	115,9	76,3	145,0	83,9	159,4	91,5	173,9	127,0
12,5	6,3	25	42,1	5,0	210,5	6,3	265,2	6,9	290,5	7,5	315,8	9,8
		32	33,2	6,4	212,5	8,0	265,6	8,8	292,2	9,6	318,7	13,6
		38	29,3	7,6	222,7	9,5	278,4	10,5	307,7	11,4	334,0	14,6
		44	24,6	8,8	216,5	11,0	270,6	12,1	297,7	13,2	324,7	18,1
		51	19,6	10,2	199,9	12,8	250,9	14,0	274,4	15,3	299,9	22,3
		64	15,0	12,8	192,0	16,0	240,0	17,6	264,0	19,2	288,0	27,3
		76	13,2	15,2	200,6	19,0	250,8	20,9	275,9	22,8	301,0	33,1
		89	11,4	17,8	202,9	22,3	254,2	24,5	279,3	26,7	304,4	38,9
2,4 x 1,9		305	3,2	61,0	195,2	76,3	244,2	83,9	268,5	91,5	292,8	140,0
16	8	25	75,7	5,0	378,5	6,3	476,9	6,9	522,3	7,5	567,8	8,4
		32	60,2	6,4	385,3	8,0	481,6	8,8	529,8	9,6	577,9	10,5
		38	50,8	7,6	386,1	9,5	482,6	10,5	533,4	11,4	579,1	13,6
		44	42,8	8,8	376,6	11,0	470,8	12,1	517,9	13,2	565,0	15,9
		51	37,1	10,2	378,4	12,8	474,9	14,0	519,4	15,3	567,6	18,9
		64	30,3	12,8	387,8	16,0	484,8	17,6	533,3	19,2	581,8	24,9
		76	25,7	15,2	390,6	19,0	488,3	20,9	537,1	22,8	586,0	29,2
		89	21,7	17,8	386,3	22,3	483,9	24,5	531,7	26,7	579,4	34,5
		102	18,9	20,4	385,6	25,5	482,0	28,1	531,1	30,6	578,3	39,1
		115	15,7	23,0	361,1	28,8	452,2	31,6	496,1	34,5	541,7	44,0
3,1 x 2,5		305	6,3	61,0	384,3	76,3	480,7	83,9	528,6	91,5	576,5	104,0





Continúa en la siguiente página...
Continue next page...

Forma de pedido: RNR + D1 * L
How to order: RNR + D1 * L

MUELLE RECTANGULAR CARGA FUERTE RNR

HEAVY LOAD RECTANGULAR SPRINGS RNR





RNR

D1	D2	L	R	A		B		C		D		E
Diámetro del alojamiento Hole diameter	Diámetro de la guía Spring inside diameter	Longitud libre Free length	Constante elástica ±10 Spring constant ±10		20% L		25% L		27.5% L		30% L	 <small>aprox. no usar prox. do not use</small>
b x h			±10%	+ 3.000.000		~ 1.500.000		300 - 500.00		100 - 200.00		
mm	mm	mm	N/mm	mm	N	mm	N	mm	N	mm	N	mm
20	10	25	216,0	5,0	1080	6,3	1361	6,9	1490	7,5	1620	8,3
		32	168,0	6,4	1075	8,0	1344	8,8	1478	9,6	1613	10,9
		38	129,0	7,6	980	9,5	1226	10,5	1355	11,4	1471	12,5
		44	112,0	8,8	986	11,0	1232	12,1	1355	13,2	1478	15,0
		51	94,0	10,2	959	12,8	1203	14,0	1316	15,3	1438	17,6
		64	72,1	12,8	923	16,0	1154	17,6	1269	19,2	1384	22,6
		76	59,7	15,2	907	19,0	1134	20,9	1248	22,8	1361	27,5
		89	50,5	17,8	899	22,3	1126	24,5	1237	26,7	1348	31,7
		102	44,2	20,4	902	25,5	1127	28,1	1242	30,6	1353	37,5
		115	38,4	23,0	883	28,8	1106	31,6	1213	34,5	1325	42,6
		127	34,1	25,4	866	31,8	1084	34,9	1190	38,1	1299	45,5
		139	31,0	27,8	862	34,8	1079	38,2	1184	41,7	1293	50,1
152	28,2	30,4	857	38,0	1072	41,8	1179	45,6	1286	55,8		
4,0 x 3,3		305	14,0	61,0	854	76,3	1068	83,9	1175	91,5	1281	114,0
25	12,5	25	375,0	5,0	1875	6,3	2363	6,9	2588	7,5	2813	8,5
		32	297,0	6,4	1901	8,0	2376	8,8	2614	9,6	2851	11,0
		38	219,0	7,6	1664	9,5	2081	10,5	2300	11,4	2497	12,6
		44	187,0	8,8	1646	11,0	2057	12,1	2263	13,2	2468	14,8
		51	156,0	10,2	1591	12,8	1997	14,0	2184	15,3	2387	17,9
		64	123,0	12,8	1574	16,0	1968	17,6	2165	19,2	2362	23,1
		76	99,0	15,2	1505	19,0	1881	20,9	2069	22,8	2257	26,3
		89	84,0	17,8	1495	22,3	1873	24,5	2058	26,7	2243	30,5
		102	73,0	20,4	1489	25,5	1862	28,1	2051	30,6	2234	37,3
		115	65,0	23,0	1495	28,8	1872	31,6	2054	34,5	2243	41,9
		127	57,7	25,4	1466	31,8	1835	34,9	2014	38,1	2198	46,2
		139	52,7	27,8	1465	34,8	1834	38,2	2013	41,7	2198	49,3
152	47,8	30,4	1453	38,0	1816	41,8	1998	45,6	2180	55,7		
178	41,0	35,6	1460	44,5	1825	49,0	2009	53,4	2189	65,1		
203	35,8	40,6	1453	50,8	1819	55,8	1998	60,9	2180	74,5		
5,5 x 4,2		305	22,9	61,0	1397	76,3	1747	83,9	1921	91,5	2095	110,0
32	16	38	388,0	7,6	2949	9,5	3686	10,5	4074	11,4	4423	12,5
		44	324,0	8,8	2851	11,0	3564	12,1	3920	13,2	4277	14,9
		51	272,0	10,2	2774	12,8	3482	14,0	3808	15,3	4162	17,8
		64	212,0	12,8	2714	16,0	3392	17,6	3731	19,2	4070	22,4
		76	172,0	15,2	2614	19,0	3268	20,9	3595	22,8	3922	26,1
		89	141,0	17,8	2510	22,3	3144	24,5	3455	26,7	3765	30,8
		102	122,0	20,4	2489	25,5	3111	28,1	3428	30,6	3733	36,8
		115	107,0	23,0	2461	28,8	3082	31,6	3381	34,5	3692	41,4
		127	93,0	25,4	2362	31,8	2957	34,9	3246	38,1	3543	44,4
139	86,0	27,8	2391	34,8	2993	38,2	3285	41,7	3586	48,5		

Continúa en la siguiente página...
Continue next page...

Forma de pedido: RNR + D1 * L
How to order: RNR + D1 * L

RNR

D1	D2	L	R		A		B		C		D		E
Diámetro del alojamiento Hole diameter	Diámetro de la guía Spring inside diameter	Longitud libre Free length	Constante elástica ±10 Spring constant ±10		20% L		25% L		27.5% L		30% L		aprox. no usar aprox. do not use
b x h			±10%	+ 3.000.000		~ 1.500.000		300 - 500.00		100 - 200.00			
mm	mm	mm	N/mm	mm	N	mm	N	mm	N	mm	N	mm	
32	16	152	78,0	30,4	2371	38,0	2964	41,8	3260	45,6	3557	54,8	
		178	67,2	35,6	2392	44,5	2990	49,0	3293	53,4	3588	63,6	
		203	59,1	40,6	2399	50,8	3002	55,8	3298	60,9	3599	72,5	
		254	46,4	50,8	2357	63,5	2946	69,9	3243	76,2	3536	92,8	
7,1 x 5,4		305	38,0	61,0	2318	76,3	2899	83,9	3188	91,5	3477	112,0	
40	20	51	350,0	10,2	3570	12,8	4480	14,0	4900	15,3	5355	17,0	
		64	269,0	12,8	3443	16,0	4304	17,6	4734	19,2	5165	21,9	
		76	219,0	15,2	3329	19,0	4161	20,9	4577	22,8	4993	26,7	
		89	190,0	17,8	3382	22,3	4237	24,5	4655	26,7	5073	31,3	
		102	163,0	20,4	3325	25,5	4157	28,1	4580	30,6	4988	37,1	
		115	142,0	23,0	3266	28,8	4090	31,6	4487	34,5	4899	41,0	
		127	128,0	25,4	3251	31,8	4070	34,9	4467	38,1	4877	46,5	
		139	115,0	27,8	3197	34,8	4002	38,2	4393	41,7	4796	53,1	
		152	105,0	30,4	3192	38,0	3990	41,8	4389	45,6	4788	56,1	
		178	89,0	35,6	3168	44,5	3961	49,0	4361	53,4	4753	67,4	
		203	77,0	40,6	3126	50,8	3912	55,8	4297	60,9	4689	76,2	
254	61,0	50,8	3099	63,5	3874	69,9	4264	76,2	4648	96,2			
8,4 x 6,2		305	51,0	61,0	3111	76,3	3891	83,9	4279	91,5	4667	115,0	
50	25	64	413,0	12,8	5286	16,0	6608	17,6	7269	19,2	7930	22,4	
		76	339,0	15,2	5153	19,0	6441	20,9	7085	22,8	7729	26,5	
		89	288,0	17,8	5126	22,3	6422	24,5	7056	26,7	7690	31,5	
		102	245,0	20,4	4998	25,5	6248	28,1	6885	30,6	7497	37,6	
		115	215,0	23,0	4945	28,8	6192	31,6	6794	34,5	7418	42,7	
		127	192,0	25,4	4877	31,8	6106	34,9	6701	38,1	7315	47,5	
		139	168,0	27,8	4670	34,8	5846	38,2	6418	41,7	7006	51,8	
		152	154,0	30,4	4682	38,0	5852	41,8	6437	45,6	7022	57,8	
		178	134,0	35,6	4770	44,5	5963	49,0	6566	53,4	7156	68,5	
		203	117,0	40,6	4750	50,8	5944	55,8	6529	60,9	7125	77,6	
		254	89,0	50,8	4521	63,5	5652	69,9	6221	76,2	6782	97,9	
11,1 x 7,6		305	73,0	61,0	4453	76,3	5570	83,9	6125	91,5	6680	121,0	
63	38	76	618,0	15,2	9394	19,0	11742	20,9	12916	22,8	14090	24,7	
		89	515,0	17,8	9167	22,3	11485	24,5	12618	26,7	13751	30,0	
		102	438,0	20,4	8935	25,5	11169	28,1	12308	30,6	13403	35,1	
		115	370,0	23,0	8510	28,8	10656	31,6	11692	34,5	12765	37,5	
		127	333,0	25,4	8458	31,8	10589	34,9	11622	38,1	12687	45,9	
		152	269,0	30,4	8178	38,0	10222	41,8	11244	45,6	12266	56,5	
		178	226,0	35,6	8046	44,5	10057	49,0	11074	53,4	12068	66,8	
		203	198,0	40,6	8039	50,8	10058	55,8	11048	60,9	12058	78,8	
		254	155,0	50,8	7874	63,5	9843	69,9	10835	76,2	11811	102,0	
11,6 x 1,3		305	128,0	61,0	7808	76,3	9766	83,9	10739	91,5	11712	122,0	

Forma de pedido: RNR + D1 * L
How to order: RNR + D1 * L

MUELLE RECTANGULAR CARGA EXTRA-FUERTE RNG EXTRA-HEAVY LOAD RECTANGULAR SPRINGS RNG

STOCK

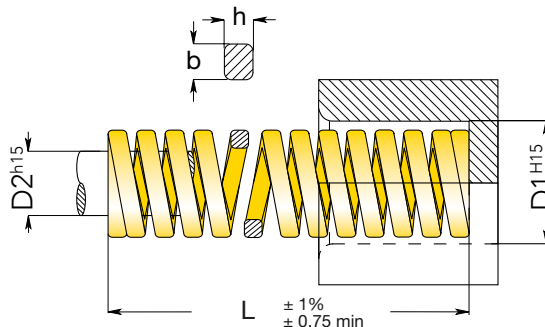

RNG

Norma / Standard: ISO 10243





D1	D2	L	R	A	B	C	D	E				
Diámetro del alojamiento Hole diameter	Diámetro de la guía Spring inside diameter	Longitud libre Free length	Constante elástica ±10 Spring constant ±10	17% L	20% L	22.5% L	25% L	 aprox. no usar aprox. do not use				
b x h			±10%	+ 3.000.000	~ 1.500.000	300 - 500.00	100 - 200.00					
mm	mm	mm	N/mm	mm N	mm N	mm N	mm N	mm				
10	5	25	36,8	4,3	158,2	5,0	184,0	5,6	206,1	6,2	228,2	7,7
		32	27,9	5,4	150,7	6,4	178,6	7,2	200,9	8,0	223,2	10,6
		38	23,7	6,5	154,1	7,6	180,1	8,6	203,8	9,5	225,2	12,6
		44	19,2	7,5	144,0	8,8	169,0	9,9	190,1	11,0	211,2	13,8
		51	16,5	8,7	143,6	10,2	168,3	11,5	189,8	12,7	209,6	16,2
		64	13,2	10,9	143,9	12,8	169,0	14,4	190,1	16,0	211,2	20,4
		76	10,9	12,9	140,6	15,2	165,7	17,1	186,4	19,0	207,1	25,2
1,9 x 1,6		305	2,6	51,9	134,9	61,0	158,6	68,6	178,4	76,3	198,4	111,0
12,5	6,3	25	58,5	4,3	251,6	5,0	292,5	5,6	327,6	6,2	362,7	8,1
		32	43,9	5,4	237,1	6,4	281,0	7,2	316,1	8,0	351,2	9,9
		38	36,0	6,5	234,0	7,6	273,6	8,6	309,6	9,5	342,0	12,9
		44	30,3	7,5	227,3	8,8	266,6	9,9	300,0	11,0	333,3	14,1
		51	26,2	8,7	227,9	10,2	267,2	11,5	301,3	12,7	332,7	17,4
		64	21,2	10,9	231,1	12,8	271,4	14,4	305,3	16,0	339,2	21,0
		76	17,1	12,9	220,6	15,2	259,9	17,1	292,4	19,0	324,9	26,4
		89	14,5	15,1	219,0	17,8	258,1	20,0	290,0	22,2	321,9	31,5
2,6 x 2,0		305	4,3	51,9	223,2	61,0	262,3	68,6	295,0	76,3	328,1	111,0
16	8	25	118,0	4,3	507,4	5,0	590,0	5,6	660,8	6,2	731,6	8,5
		32	89,0	5,4	480,6	6,4	569,6	7,2	640,8	8,0	712,0	11,0
		38	72,1	6,5	468,7	7,6	548,0	8,6	620,1	9,5	685,0	13,2
		44	60,9	7,5	456,8	8,8	535,9	9,9	602,9	11,0	669,9	14,7
		51	52,3	8,7	455,0	10,2	533,5	11,5	601,5	12,7	664,2	17,7
		64	41,2	10,9	449,1	12,8	527,4	14,4	593,3	16,0	659,2	21,9
		76	34,1	12,9	439,9	15,2	518,3	17,1	583,1	19,0	647,9	27,8
		89	29,5	15,1	445,5	17,8	525,1	20,0	590,0	22,2	654,9	31,2
		102	25,6	17,3	442,9	20,4	522,2	23,0	588,8	25,5	652,8	37,9
		115	22,4	19,6	439,0	23,0	515,2	25,9	580,2	28,7	642,9	44,5
3,2 x 2,9		305	8,4	51,9	436,0	61,0	512,4	68,6	576,2	76,3	640,9	113,0

Continúa en la siguiente página...
Continue next page...

Forma de pedido: RNG + D1 * L
How to order: RNG + D1 * L

MUELLE RECTANGULAR CARGA EXTRA-FUERTE RNG
EXTRA-HEAVY LOAD RECTANGULAR SPRINGS RNG

RNG

D1	D2	L	R	A	B	C	D	E				
Diámetro del alojamiento Hole diameter	Diámetro de la guía Spring inside diameter	Longitud libre Free lenght	Constante elástica ±10 Spring constant ±10	 17% L	 20% L	 22.5% L	 25% L	 <small>aprox. no usar aprox. do not use</small>				
b x h			±10%	+ 3.000.000	~ 1.500.000	300 - 500.00	100 - 200.00					
mm	mm	mm	N/mm	mm N	mm N	mm N	mm N	mm				
20	10	25	293,0	4,3	1260	5,0	1465	5,6	1641	6,2	1817	6,9
		32	224,0	5,4	1210	6,4	1434	7,2	1613	8,0	1792	9,4
		38	177,0	6,5	1151	7,6	1345	8,6	1522	9,5	1682	12,0
		44	149,0	7,5	1118	8,8	1311	9,9	1475	11,0	1639	13,5
		51	128,0	8,7	1114	10,2	1306	11,5	1472	12,7	1626	16,2
		64	99,0	10,9	1079	12,8	1267	14,4	1426	16,0	1584	21,2
		76	81,7	12,9	1054	15,2	1242	17,1	1397	19,0	1552	24,7
		89	69,5	15,1	1049	17,8	1237	20,0	1390	22,2	1543	28,8
		102	60,6	17,3	1048	20,4	1236	23,0	1394	25,5	1545	34,8
		115	53,0	19,6	1039	23,0	1219	25,9	1373	28,7	1521	39,0
		127	47,5	21,6	1026	25,4	1207	28,6	1359	31,7	1506	43,0
		139	43,0	23,6	1015	27,8	1195	31,3	1346	34,7	1492	45,3
		152	39,0	25,8	1006	30,4	1186	34,2	1334	38,0	1482	50,4
4,1 x 3,8		305	20,0	51,9	1038	61,0	1220	68,6	1372	76,3	1526	103,0
25	12,5	25	459,0	4,3	1974	5,0	2295	5,6	2570	6,3	2892	6,7
		32	374,0	5,4	2020	6,4	2394	7,2	2693	8,0	2992	10,7
		38	300,0	6,5	1950	7,6	2280	8,6	2580	9,5	2850	12,0
		44	244,0	7,5	1830	8,8	2147	9,9	2416	11,0	2684	14,4
		51	208,0	8,7	1810	10,2	2122	11,5	2392	12,8	2662	17,4
		64	161,0	10,9	1755	12,8	2061	14,4	2318	16,0	2576	21,4
		76	131,0	12,9	1690	15,2	1991	17,1	2240	19,0	2489	26,9
		89	111,0	15,1	1676	17,8	1976	20,0	2220	22,3	2475	30,9
		102	96,3	17,3	1666	20,4	1965	23,0	2210	25,5	2456	36,7
		115	85,7	19,6	1680	23,0	1971	25,9	2217	28,8	2468	40,3
		127	76,3	21,6	1648	25,4	1938	28,6	2180	31,8	2426	45,1
		139	66,0	23,6	1558	27,8	1835	31,3	2066	34,8	2297	47,6
		152	63,5	25,8	1638	30,4	1930	34,2	2172	38,0	2413	53,5
178	53,9	30,3	1633	35,6	1919	40,1	2159	44,5	2399	63,9		
203	47,0	34,5	1622	40,6	1908	45,7	2147	50,8	2388	70,2		
5,4 x 4,6		305	30,9	51,9	1604	61,0	1885	68,6	2121	76,3	2358	110
32	16	38	480,0	6,5	3120	7,6	3648	8,6	4128	9,5	4560	11,4
		44	390,0	7,5	2925	8,8	3432	9,9	3861	11,0	4290	13,7
		51	336,0	8,7	2923	10,2	3427	11,5	3864	12,7	4267	15,6
		64	269,0	10,9	2932	12,8	3443	14,4	3874	16,0	4304	20,0
		76	219,0	12,9	2825	15,2	3329	17,1	3745	19,0	4161	24,4
		89	180,0	15,1	2718	17,8	3204	20,0	3600	22,2	3996	29,7
		102	155,0	17,3	2682	20,4	3162	23,0	3565	25,5	3953	35,1
		115	140,0	19,6	2744	23,0	3220	25,9	3626	28,7	4018	39,0
		127	124,0	21,6	2678	25,4	3150	28,6	3546	31,7	3931	42,8
		139	112,0	23,6	2643	27,8	3114	31,3	3506	34,7	3886	48





Continúa en la siguiente página...
Continue next page...

Forma de pedido: RNG + D1 * L
How to order: RNG + D1 * L

MUELLE RECTANGULAR CARGA EXTRA-FUERTE RNG

EXTRA-HEAVY LOAD RECTANGULAR SPRINGS RNG

RNG

D1	D2	L	R		A		B		C		D		E
Diámetro del alojamiento Hole diameter	Diámetro de la guía Spring inside diameter	Longitud libre Free length	Constante elástica ±10 Spring constant ±10		17% L		20% L		22.5% L		25% L		aprox. no usar aprox. do not use
b x h			±10%		+ 3.000.000		~ 1.500.000		300 - 500.00		100 - 200.00		
mm	mm	mm	N/mm	mm	N	mm	N	mm	N	mm	N	mm	mm
32	16	152	102,0	25,8	2632	30,4	3101	34,2	3488	38,0	3876	52,4	
		178	88,2	30,3	2672	35,6	3140	40,1	3537	44,5	3925	60,9	
		203	76,0	34,5	2622	40,6	3086	45,7	3473	50,7	3853	69,2	
		254	60,8	43,2	2627	50,8	3089	57,2	3478	64,0	3861	88,1	
7,3 x 5,9		305	49,0	51,9	2543	61,0	2989	68,6	3361	76,3	3739	104,0	
40	20	51	628,0	8,7	5464	10,2	6406	11,5	7222	12,7	7976	15,0	
		64	487,0	10,9	5308	12,8	6234	14,4	7013	16,0	7792	19,5	
		76	379,0	12,9	4889	15,2	5761	17,1	6481	19,0	7201	23,3	
		89	321,0	15,1	4847	17,8	5714	20,0	6420	22,2	7126	26,7	
		102	281,0	17,3	4861	20,4	5732	23,0	6463	25,5	7165	33,8	
		115	245,0	19,6	4802	23,0	5635	25,9	6346	28,7	7032	36,2	
		127	221,0	21,6	4774	25,4	5613	28,6	6321	31,7	7006	40,7	
		139	185,0	23,6	4366	27,8	5143	31,3	5791	34,7	6420	42,0	
		152	168,0	25,8	4334	30,4	5107	34,2	5746	38,0	6384	49,6	
		178	150,0	30,3	4545	35,6	5340	40,1	6015	44,5	6675	56,5	
		203	132,0	34,5	4554	40,6	5359	45,7	6032	50,7	6692	67,1	
		254	107,0	43,2	4622	50,8	5436	57,2	6120	64,0	6848	86,3	
8,4 x 7,5		305	87,8	51,9	4557	61,0	5356	68,6	6023	76,3	6699	104,0	
50	25	64	709,0	10,9	7728	12,8	9075	14,4	10210	16,0	11344	19,3	
		76	572,0	12,9	7379	15,2	8694	17,1	9781	19,0	10868	24,2	
		89	475,0	15,1	7173	17,8	8455	20,0	9500	22,2	10545	28,0	
		102	405,0	17,3	7007	20,4	8262	23,0	9315	25,5	10328	33,5	
		115	352,0	19,6	6899	23,0	8096	25,9	9117	28,7	10102	38,6	
		127	316,0	21,6	6826	25,4	8026	28,6	9038	31,7	10017	41,4	
		139	289,0	23,6	6820	27,8	8034	31,3	9046	34,7	10028	47,3	
		152	255,0	25,8	6579	30,4	7752	34,2	8721	38,0	9690	50,2	
		178	215,0	30,3	6515	35,6	7654	40,1	8622	44,5	9568	61,1	
		203	187,0	34,5	6452	40,6	7592	45,7	8546	50,7	9481	67,7	
254	153,0	43,2	6610	50,8	7772	57,2	8752	64,0	9792	87,0			
11,5 x 9,0		305	127,0	51,9	6591	61,0	7747	68,6	8712	76,3	9690	104,0	
63	38	76	952,0	12,9	12281	15,2	14470	-	-	-	-	15,5	
		89	819,0	15,1	12367	17,8	14578	-	-	-	-	20,0	
		102	700,0	17,3	12110	20,4	14280	23,0	16100	25,5	17850	30,7	
		115	620,0	19,6	12152	23,0	14260	25,9	16058	28,7	17860	34,9	
		127	565,0	21,6	12204	25,4	14351	28,6	16159	31,7	17967	38,0	
		152	458,0	25,8	11816	30,4	13923	34,2	15664	38,0	17404	47,2	
		178	384,0	30,3	11635	35,6	13670	40,1	15398	44,5	17088	55,8	
		203	337,0	34,5	11627	40,6	13682	45,7	15401	50,7	17120	64,8	
254	263,0	43,2	11362	50,8	13360	57,2	15044	63,5	16701	86,7			
11,6 x 14,9		305	218,0	51,9	11314	61,0	13298	68,6	14955	76,3	16633	106,0	

Forma de pedido: RNG + D1 * L
How to order: RNG + D1 * L

MUELLE RECTANGULAR CARGA ULTRA-FUERTE RNA ULTRA-HEAVY LOAD RECTANGULAR SPRINGS RNA

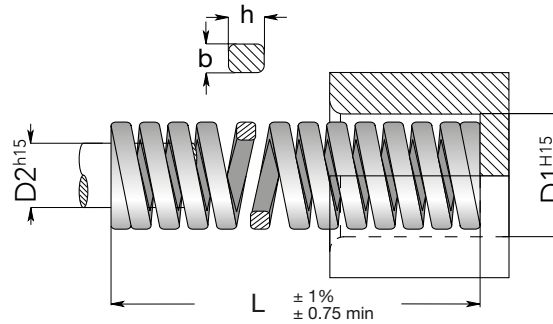

RNA

D1	D2	L	R	A	B	C	D	E				
Diámetro del alojamiento Hole diameter	Diámetro de la guía Spring inside diameter	Longitud libre Free length	Constante elástica ±10 Spring constant ±10	10% L	12% L	13.5% L	15% L	aprox. no usar aprox. do not use				
b x h		±10%	+ 3.000.000	~ 1.500.000	300 - 500.00	100 - 200.00						
mm	mm	mm	N/mm	mm N	mm N	mm N	mm N	mm				
10	5	25	167,0	2,5	417,5	3,0	501,0	3,4	567,8	3,8	634,6	5,9
		32	130,0	3,2	416,0	3,8	494,0	4,3	559,0	4,8	624,0	7,5
		38	105,0	3,8	399,0	4,6	483,0	5,1	535,5	5,7	598,5	8,2
		44	86,0	4,4	378,4	5,3	455,8	5,9	507,4	6,6	567,6	11,0
		51	79,0	5,1	402,9	6,1	481,9	6,9	545,1	7,7	608,3	12,5
		64	62,0	6,4	396,8	7,7	477,4	8,6	533,2	9,6	595,2	15,8
		76	51,0	7,6	387,6	9,1	464,1	10,3	525,3	11,4	581,4	19,0
2,0 x 2,8		305	11,5	30,5	350,8	36,6	420,9	41,2	473,8	45,8	526,7	89,0
12,5	6,3	25	288,0	2,5	720	3,0	864	3,4	979	3,8	1094	5,6
		32	216,0	3,2	691	3,8	821	4,3	929	4,8	1037	7,3
		38	176,0	3,8	669	4,6	810	5,1	898	5,7	1003	9,2
		44	149,0	4,4	656	5,3	790	5,9	879	6,6	983	11,1
		51	128,0	5,1	653	6,1	781	6,9	883	7,7	986	12,6
		64	100,0	6,4	640	7,7	770	8,6	860	9,6	960	16,1
		76	84,0	7,6	638	9,1	764	10,3	865	11,4	958	19,3
		89	71,0	8,9	632	10,7	760	12,0	852	13,4	951	23,3
102	61,0	10,2	622	12,2	744	13,8	842	15,3	933	26,9		
2,75 x 3,4		305	22,0	30,5	671	36,6	805	41,2	906	45,8	1008	94,0
16	8	32	449,0	3,2	1437	3,8	1706	4,3	1931	4,8	2155	6,6
		38	363,0	3,8	1379	4,6	1670	5,1	1851	5,7	2069	8,1
		44	309,0	4,4	1360	5,3	1638	5,9	1823	6,6	2039	10,1
		51	256,0	5,1	1306	6,1	1562	6,9	1766	7,7	1971	11,3
		64	203,0	6,4	1299	7,7	1563	8,6	1746	9,6	1949	14,3
		76	166,0	7,6	1262	9,1	1511	10,3	1710	11,4	1892	18,0
		89	139,0	8,9	1237	10,7	1487	12,0	1668	13,4	1863	20,5
		102	114,0	10,2	1163	12,2	1391	13,8	1573	15,3	1744	24,3
		115	105,0	11,5	1208	13,8	1449	15,5	1628	17,3	1817	27,0
		127	94,0	12,7	1194	15,2	1429	17,1	1607	19,1	1795	31,5
		152	78,0	15,2	1186	18,2	1420	20,5	1599	22,8	1778	38,0
3,5 x 4,75		305	38,8	30,5	1183	36,6	1420	41,2	1599	45,8	1777	77,2





Continúa en la siguiente página...
Continue next page...

Forma de pedido: RNA + D1 * L
How to order: RNA + D1 * L

MUELLE RECTANGULAR CARGA ULTRA-FUERTE RNA

ULTRA-HEAVY LOAD RECTANGULAR SPRINGS RNA





RNA

D1	D2	L	R		A		B		C		D		E
Diámetro del alojamiento Hole diameter	Diámetro de la guía Spring inside diameter	Longitud libre Free length	Constante elástica ±10 Spring constant ±10		10% L		12% L		13.5% L		15% L		aprox. no usar aprox. do not use
b x h			±10%		+ 3.000.000		~ 1.500.000		300 - 500.00		100 - 200.00		
mm	mm	mm	N/mm	mm	N	mm	N	mm	N	mm	N	mm	mm
20	10	44	452,0	4,4	1989	5,3	2396	5,9	2667	6,6	2983	8,9	
		51	378,0	5,1	1928	6,1	2306	6,9	2608	7,7	2911	10,6	
		64	301,0	6,4	1926	7,7	2318	8,6	2589	9,6	2890	13,8	
		76	247,0	7,6	1877	9,1	2248	10,3	2544	11,4	2816	16,2	
		89	208,0	8,9	1851	10,7	2226	12,0	2496	13,4	2787	20,1	
		102	188,0	10,2	1918	12,2	2294	13,8	2594	15,3	2876	22,3	
		115	159,0	11,5	1829	13,8	2194	15,5	2465	17,3	2751	25,5	
		127	146,0	12,7	1854	15,2	2219	17,1	2497	19,1	2789	27,9	
		152	120,0	15,2	1824	18,2	2184	20,5	2460	22,8	2736	34,1	
4,0 x 6,0		305	60,0	30,5	1830	36,6	2196	41,2	2472	45,8	2748	68,8	
25	12,5	44	1158,0	4,4	5095	5,3	6137	5,9	6832	6,6	7643	9,8	
		51	933,0	5,1	4758	6,1	5691	6,9	6438	7,7	7184	11,0	
		64	644,0	6,4	4122	7,7	4959	8,6	5538	9,6	6182	13,0	
		76	556,0	7,6	4226	9,1	5060	10,3	5727	11,4	6338	16,0	
		89	462,0	8,9	4112	10,7	4943	12,0	5544	13,4	6191	20,0	
		102	390,0	10,2	3978	12,2	4758	13,8	5382	15,3	5967	23,0	
		115	360,0	11,5	4140	13,8	4968	15,5	5580	17,3	6228	26,0	
		127	326,0	12,7	4140	15,2	4955	17,1	5575	19,1	6227	28,0	
		152	255,0	15,2	3876	18,2	4641	20,5	5228	22,8	5814	34,0	
		178	230,0	17,8	4094	21,4	4922	24,0	5520	26,7	6141	39,0	
203	202,0	20,3	4101	24,4	4929	27,4	5535	30,5	6161	45,0			
5,6 x 7,5		305	136,0	30,5	4148	36,6	4978	41,2	5603	45,8	6229	63,0	
32	16	44	1300,0	4,4	5720	5,3	6890	5,9	7670	6,6	8580	9,3	
		51	1150,0	5,1	5865	6,1	7015	6,9	7935	7,7	8855	10,4	
		64	1077,0	6,4	6893	7,7	8293	8,6	9262	9,6	10339	13,0	
		76	874,0	7,6	6642	9,1	7953	10,3	9002	11,4	9964	16,0	
		89	721,0	8,9	6417	10,7	7715	12,0	8652	13,4	9661	20,0	
		102	620,0	10,2	6324	12,2	7564	13,8	8556	15,3	9486	23,0	
		115	560,0	11,5	6440	13,8	7728	15,5	8680	17,3	9688	26,0	
		127	496,0	12,7	6299	15,2	7539	17,1	8582	19,1	9474	28,0	
		152	408,0	15,2	6202	18,2	7426	20,5	8364	22,8	9302	34,0	
		178	353,0	17,8	6283	21,4	7554	24,0	8472	26,7	9425	39,0	
		203	304,0	20,3	6171	24,4	7418	27,4	8330	30,5	9272	45,0	
		254	243,0	25,4	6172	30,5	7412	34,3	8335	38,1	9258	62,0	
7,5 x 9,2		305	196,0	30,5	5978	36,6	7174	41,2	8075	45,8	8977	75,0	
40	20	64	1128,0	6,4	7219	7,7	8686	8,6	9701	9,6	10829	12,0	
		76	1017,0	7,6	7729	9,1	9255	10,3	10475	11,4	11594	14,5	
		89	880,0	8,9	7832	10,7	9416	12,0	10560	13,4	11792	20,0	
		102	762,0	10,2	7772	12,2	9296	13,8	10516	15,3	11659	23,0	
		115	679,0	11,5	7809	13,8	9370	15,5	10525	17,3	11747	26,0	

Continúa en la siguiente página...
Continue next page...

Forma de pedido: RNA + D1 * L
How to order: RNA + D1 * L

RNA

D1	D2	L	R		A		B		C		D		E
Diámetro del alojamiento Hole diameter	Diámetro de la guía Spring inside diameter	Longitud libre Free length	Constante elástica ±10 Spring constant ±10		10% L		12% L		13.5% L		15% L		aprox. no usar aprox. do not use
b x h			±10%	+ 3.000.000	N	- 1.500.000	N	300 - 500.00	N	100 - 200.00	N		mm
mm	mm	mm	N/mm	mm	N	mm	N	mm	N	mm	N		mm
40	20	127	622,0	12,7	7899	15,2	9454	17,1	10636	19,1	11880		28,0
		152	509,0	15,2	7737	18,2	9264	20,5	10435	22,8	11605		36,0
		178	429,0	17,8	7636	21,4	9181	24,0	10296	26,7	11454		43,0
		203	374,0	20,3	7592	24,4	9126	27,4	10248	30,5	11407		49,0
		254	296,0	25,4	7518	30,5	9028	34,3	10153	38,1	11278		62,0
8,5 x 11,0		305	246,0	30,5	7503	36,6	9004	41,2	10135	45,8	11267		75,0
50	25	64	1980,0	6,4	12672	7,7	15246	8,6	17028	9,6	19008		13,4
		76	1811,0	7,6	13764	9,1	16480	10,3	18653	11,4	20645		16,3
		89	1410,0	8,9	12549	10,7	15087	12,0	16920	13,4	18894		19,0
		102	1215,0	10,2	12393	12,2	14823	13,8	16767	15,3	18590		22,0
		115	1076,0	11,5	12374	13,8	14849	15,5	16678	17,3	18615		25,0
		127	968,0	12,7	12294	15,2	14714	17,1	16553	19,1	18489		28,0
		152	806,0	15,2	12251	18,2	14669	20,5	16523	22,8	18377		34,0
		178	698,0	17,8	12424	21,4	14937	24,0	16752	26,7	18637		40,0
		203	612,0	20,3	12424	24,4	14933	27,4	16769	30,5	18666		45,0
254	472,0	25,4	11989	30,5	14396	34,3	16190	38,1	17983		58,0		
11,8 x 13,5		305	388,0	30,5	11834	36,6	14201	41,2	15986	45,8	17770		70,0
63	38	76	1900,0	7,6	14440	9,1	17290	10,3	19570	11,4	21660		13,0
		89	1517,0	8,9	13501	10,7	16232	12,0	18204	13,4	20328		20,0
		102	1295,0	10,2	13209	12,2	15799	13,8	17871	15,3	19814		23,0
		115	1070,0	11,5	12305	13,8	14766	15,5	16585	17,3	18511		27,0
		127	979,0	12,7	12433	15,2	14881	17,1	16741	19,1	18699		30,0
		152	775,0	15,2	11780	18,2	14105	20,5	15888	22,8	17670		35,0
		178	630,0	17,8	11214	21,4	13485	24,0	15120	26,7	16821		44,0
		203	546,0	20,3	11084	24,4	13322	27,4	14960	30,5	16653		48,0
		254	423,0	25,4	10744	30,5	12902	34,3	14509	38,1	16116		62,0
11,8 x 17,8		305	349,0	30,5	10645	36,6	12773	41,2	14379	45,8	15984		77,0

Forma de pedido: RNA + D1 * L
How to order: RNA + D1 * L

MUELLE RECTANGULAR CARGA SÚPER-FUERTE RNT

SUPER-STRONG LOAD RECTANGULAR SPRINGS RNT

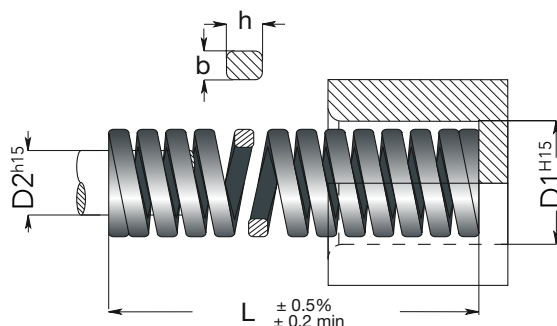
RNT

- Carga máxima hasta 6 veces la de la serie extra fuerte (color amarillo).
- Carga máxima hasta 2 veces la de la serie ultra fuerte (color plata). Ideal para cargas extremadamente altas con carreras cortas. Máxima durabilidad en ambientes agresivos con contaminantes y altas temperaturas.

- Maximum force up to 6 times the extra strong springs (ISO yellow color).
- Maximum force over 2 times the ultra strong springs (Special Springs standard silver coulor). Ideal for extremely high loads with small work strokes. Maximum duration in difficult environments with contaminants and high temperatures."

D1	D2	L	R		F
Diámetro del alojamiento Hole diameter	Diámetro de la guía Spring inside diameter	Longitud libre Free length	Constante elástica ±10 Spring constant ±10		max
b x h			±10%		
mm	mm	mm	N/mm	mm	N
10	5	20	580,0	2,2	1250
		30	360,0	3,5	1250
		40	260,0	4,8	1250
2,1 x 4		50	200,0	6,0	1250
12,5	6,3	20	970,0	2,4	2000
		30	590,0	3,3	2000
		40	400,0	5,0	2000
2,65 x 5,35		50	320,0	6,0	2000
16	8	20	1650,0	2,1	3500
		35	920,0	3,8	3500
		50	580,0	6,0	3500
		75	410,0	8,5	3500
3,4 x 6,9		100	280,0	12,5	3500
19	10	25	2270,0	2,2	5000
		40	1160,0	4,3	5000
		50	830,0	6,0	5000
		75	500,0	10,0	5000
4,1 x 8,3		100	380,0	14,0	5000
25	12,5	30	4550,0	2,2	10000
		50	2000,0	5,0	10000
		60	1500,0	6,5	10000
		75	1250,0	8,0	10000
		100	900,0	11,1	10000
6 x 11		125	710,0	14,0	

D1	D2	L	R		F
Diámetro del alojamiento Hole diameter	Diámetro de la guía Spring inside diameter	Longitud libre Free length	Constante elástica ±10 Spring constant ±10		max
b x h			±10%		
mm	mm	mm	N/mm	mm	N
32	16	35	5360,0	2,8	15000
		50	3000,0	5,0	15000
		75	1670,0	9,0	15000
		100	1200,0	12,5	15000
		125	940,0	16,0	15000
7,4 x 13		150	810,0	18,5	15000
38	20	40	5710,0	3,5	20000
		50	4000,0	5,0	20000
		75	2220,0	9,0	20000
		100	1540,0	13,0	20000
		150	1050,0	19,0	20000
8,25 x 16		200	740,0	27,0	20000
50	25	60	4605,0	7,6	35000
		75	3932,0	8,9	35000
		100	2650,0	13,2	35000
		125	2000,0	17,5	35000
		150	1605,0	21,8	35000
11,8 x 17,8		200	1167,0	30,0	35000

Forma de pedido: RNT + D1 * L
How to order: RNT + D1 * L

MUELLE RECTANGULAR CARGA HÍPER-FUERTE RNW HYPER-STRONG LOAD RECTANGULAR SPRINGS RNW

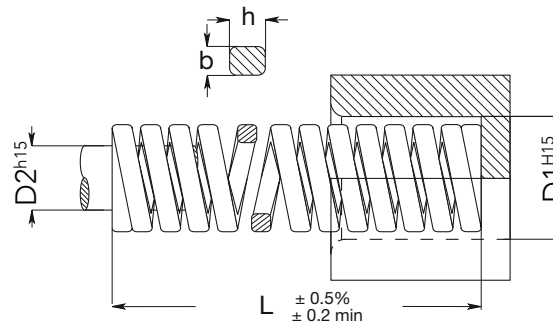

RNW

- Carga máxima hasta 6 veces la de la serie extrafuerte (color amarillo).
- Carga máxima hasta 2 veces la de la serie ultra fuerte (color plata). Ideal para cargas extremadamente altas con carreras cortas. Máxima durabilidad en ambientes agresivos con contaminantes y altas temperaturas.
- Maximum force up to 6 times the extra strong springs (ISO yellow color).
- Maximum force over 2 times the ultra strong springs (Special Springs standard silver coulor). Ideal for extremely high loads with small work strokes. Maximum duration in difficult environments with contaminants and high temperatures."

D1	D2	L	R		F
Diámetro del alojamiento Hole diameter	Diámetro de la guía Spring inside diameter	Longitud libre Free length	Constante elástica ±10 Spring constant ±10		max
b x h			±10%		
mm	mm	mm	N/mm	mm	N
16	6,3	20	1818,0	2,2	4000
		35	1000,0	4,0	4000
		50	615,0	6,5	4000
		75	400,0	10,0	4000
4,6 x 5,0		100	286,0	14,0	4000
19	8	25	2400,0	2,5	6000
		40	1333,0	4,5	6000
		50	1000,0	6,0	6000
		75	600,0	10,0	6000
		5,1 x 6,5		100	429,0
25	10	30	4800,0	2,5	12000
		50	2400,0	5,0	12000
		75	1500,0	8,0	12000
		100	1000,0	12,0	12000
		6,9 x 9,1		125	857,0

D1	D2	L	R		F
Diámetro del alojamiento Hole diameter	Diámetro de la guía Spring inside diameter	Longitud libre Free length	Constante elástica ±10 Spring constant ±10		max
b x h			±10%		
mm	mm	mm	N/mm	mm	N
32	12,5	35	6667,0	3,0	20000
		50	3636,0	5,5	20000
		75	2222,0	9,0	20000
		100	1538,0	13,0	20000
		125	1250,0	16,0	20000
9,25 x 10,8		150	1053,0	19,0	20000
38	16	40	7143,0	3,5	25000
		50	5000,0	5,0	25000
		75	2778,0	9,0	25000
		100	1923,0	13,0	25000
		150	1316,0	19,0	25000
10,5 x 12,6		200	926,0	27,0	25000

Forma de pedido: RNW + D1 * L
How to order: RNW + D1 * L

MUELLE REDONDO CARGA LIGERA RNTV
LIGHT LOAD ROUND SPRINGS RNTV

STOCK

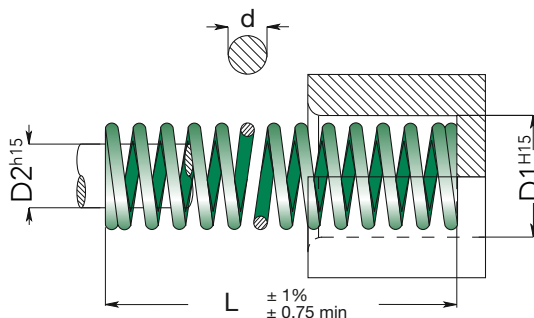

RNTV

D1	D2	L	R	A	B	C	D	E				
Diámetro del alojamiento Hole diameter	Diámetro de la guía Spring inside diameter	Longitud libre Free length	Constante elástica ±10 Spring constant ±10	25% L	30% L	35% L	40% L	aprox. no usar aprox. do not use				
d			±10%	+ 3.000.000	~ 1.500.000	300 - 500.00	100 - 200.00					
mm	mm	mm	N/mm	mm N	mm N	mm N	mm N	mm				
10	5	25	4,4	6,3	27,7	7,5	33,0	8,8	38,7	10,0	44,0	13,2
		32	3,4	8,0	27,2	9,6	32,6	11,2	38,1	12,8	43,5	16,5
		38	2,8	9,5	26,6	11,4	31,9	13,3	37,2	15,2	42,6	19,8
		44	2,4	11,0	26,4	13,2	31,7	15,4	37,0	17,6	42,2	23,1
		51	2,1	12,8	26,9	15,3	32,1	17,9	37,6	20,4	42,8	26,9
		64	1,6	16,0	25,6	19,2	30,7	22,4	35,8	25,6	41,0	33,3
		76	1,3	19,0	24,7	22,8	29,6	26,6	34,6	30,4	39,5	39,6
1,1		305	0,3	76,3	22,9	91,5	27,5	106,8	32,0	122,0	36,6	157,0
12,5	6,3	25	8,5	6,3	53,6	7,5	63,8	8,8	74,8	10,0	85,0	13,5
		32	6,5	8,0	52,0	9,6	62,4	11,2	72,8	12,8	83,2	16,8
		38	5,3	9,5	50,4	11,4	60,4	13,3	70,5	15,2	80,6	20,3
		44	4,4	11,0	48,4	13,2	58,1	15,4	67,8	17,6	77,4	23,9
		51	3,8	12,8	48,6	15,3	58,1	17,9	68,0	20,4	77,5	26,9
		64	2,9	16,0	46,4	19,2	55,7	22,4	65,0	25,6	74,2	33,3
		76	2,5	19,0	47,5	22,8	57,0	26,6	66,5	30,4	76,0	41,1
89	2,1	22,3	46,8	26,7	56,1	31,2	65,5	35,6	74,8	48,3		
1,5		305	0,6	76,3	45,8	91,5	54,9	106,8	64,1	122,0	73,2	163,0
16	8	25	17,9	6,3	112,8	7,5	134,3	8,8	157,5	10,0	179,0	14,7
		32	13,5	8,0	108,0	9,6	129,6	11,2	151,2	12,8	172,8	18,5
		38	10,5	9,5	99,8	11,4	119,7	13,3	139,7	15,2	159,6	22,4
		44	8,8	11,0	96,8	13,2	116,2	15,4	135,5	17,6	154,9	25,9
		51	7,6	12,8	97,3	15,3	116,3	17,9	136,0	20,4	155,0	30,0
		64	5,9	16,0	94,4	19,2	113,3	22,4	132,2	25,6	151,0	37,8
		76	4,8	19,0	91,2	22,8	109,4	26,6	127,7	30,4	145,9	45,2
		89	4,0	22,3	89,2	26,7	106,8	31,2	124,8	35,6	142,4	52,8
		102	3,5	25,5	89,3	30,6	107,1	35,7	125,0	40,8	142,8	60,7
2		305	1,1	76,3	83,9	91,5	100,7	106,8	117,5	122,0	134,2	184,0

Forma de pedido: RNTV + D1 * L
 How to order: RNTV + D1 * L

MUELLE REDONDO CARGA MEDIA RNTB

MEDIUM LOAD ROUND SPRINGS RNTB

STOCK

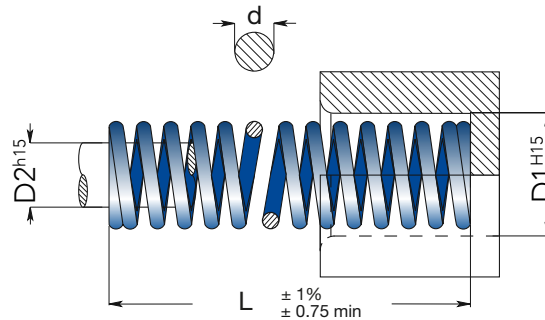

RNTB

D1	D2	L	R	A	B	C	D	E				
Diámetro del alojamiento Hole diameter	Diámetro de la guía Spring inside diameter	Longitud libre Free length	Constante elástica ±10 Spring constant ±10	25% L	30% L	33.75% L	37.5% L	 aprox. no usar aprox. do not use				
d			±10%	+ 3.000.000	- 1.500.000	300 - 500.00	100 - 200.00					
mm	mm	mm	N/mm	mm N	mm N	mm N	mm N	mm				
10	5	25	12,3	6,3	77,5	7,5	92,3	8,4	103,3	9,4	115,6	10,4
		32	9,5	8,0	76,0	9,6	91,2	10,8	102,6	12,0	114,0	13,2
		38	7,8	9,5	74,1	11,4	88,9	12,8	99,8	14,2	110,8	16,0
		44	6,5	11,0	71,5	13,2	85,8	14,9	96,9	16,5	107,3	18,5
		51	5,6	12,8	71,7	15,3	85,7	17,2	96,3	19,1	107,0	21,1
		64	4,5	16,0	72,0	19,2	86,4	21,6	97,2	24,0	108,0	26,4
		76	3,7	19,0	70,3	22,8	84,4	25,7	95,1	28,5	105,5	31,8
1,5		305	0,9	76,3	68,7	91,5	82,4	102,9	92,6	114,0	102,6	129,0
12,5	6,3	25	21,7	6,3	136,7	7,5	162,8	8,4	182,3	9,4	204,0	11,2
		32	16,8	8,0	134,4	9,6	161,3	10,8	181,4	12,0	201,6	14,0
		38	13,8	9,5	131,1	11,4	157,3	12,8	176,6	14,2	196,0	17,3
		44	11,6	11,0	127,6	13,2	153,1	14,9	172,8	16,5	191,4	19,8
		51	10,0	12,8	128,0	15,3	153,0	17,2	172,0	19,1	191,0	22,9
		64	7,8	16,0	124,8	19,2	149,8	21,6	168,5	24,0	187,2	28,4
		76	6,4	19,0	121,6	22,8	145,9	25,7	164,5	28,5	182,4	34,3
89	5,6	22,3	124,9	26,7	149,5	30,0	168,0	33,3	186,5	41,4		
1,8		305	1,5	76,3	114,5	91,5	137,3	102,9	154,4	114,0	171,0	139,0
16	8	25	31,9	6,3	201,0	7,5	239,3	8,4	268,0	9,4	299,9	10,9
		32	24,0	8,0	192,0	9,6	230,4	10,8	259,2	12,0	288,0	13,7
		38	19,4	9,5	184,3	11,4	221,2	12,8	248,3	14,2	275,5	16,5
		44	16,1	11,0	177,1	13,2	212,5	14,9	239,9	16,5	265,7	19,3
		51	13,8	12,8	176,6	15,3	211,1	17,2	237,4	19,1	263,6	22,1
		64	10,7	16,0	171,2	19,2	205,4	21,6	231,1	24,0	256,8	27,4
		76	8,8	19,0	167,2	22,8	200,6	25,7	226,2	28,5	250,8	33,0
		89	7,5	22,3	167,3	26,7	200,3	30,0	225,0	33,3	249,8	38,6
		102	6,5	25,5	165,8	30,6	198,9	34,4	223,6	38,2	248,3	44,5
2,2		305	2,1	76,3	160,2	91,5	192,2	102,9	216,1	114,0	239,4	134,0

Forma de pedido: RNTB + D1 * L
How to order: RNTB + D1 * L





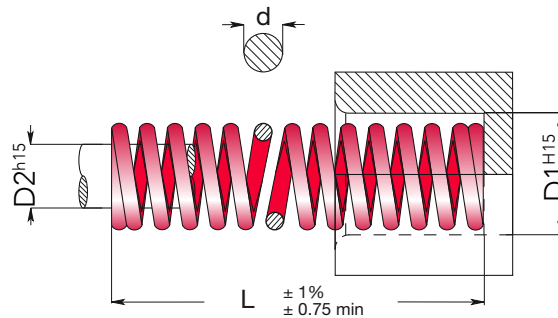

MUELLE REDONDO CARGA FUERTE RNTR

HEAVY LOAD ROUND SPRINGS RNTR

STOCK



RNTR

D1	D2	L	R	A		B		C		D		E
Diámetro del alojamiento Hole diameter	Diámetro de la guía Spring inside diameter	Longitud libre Free length	Constante elástica ±10 Spring constant ±10		20% L		25% L		27.5% L		30% L	
mm	mm	mm	N/mm	mm	N	mm	N	mm	N	mm	N	mm
			±10%	+ 3.000.000		~ 1.500.000		300 - 500.00		100 - 200.00		
10	5	25	20,7	5,0	103,5	6,3	130,4	6,9	142,8	7,5	155,3	8,6
		32	16,1	6,4	103,0	8,0	128,8	8,8	141,7	9,6	154,6	10,9
		38	13,0	7,6	98,8	9,5	123,5	10,5	136,5	11,4	148,2	13,2
		44	10,9	8,8	95,9	11,0	119,9	12,1	131,9	13,2	143,9	14,7
		51	9,6	10,2	97,9	12,8	122,9	14,0	134,4	15,3	146,9	17,8
		64	7,7	12,8	98,6	16,0	123,2	17,6	135,5	19,2	147,8	22,9
		76	6,3	15,2	95,8	19,0	119,7	20,9	131,7	22,8	143,6	26,9
1,6		305	1,5	61,0	91,5	76,3	114,5	83,9	125,9	91,5	137,3	110,0
12,5	6,3	25	37,5	5,0	187,5	6,3	236,3	6,9	258,8	7,5	281,3	8,9
		32	28,9	6,4	185,0	8,0	231,2	8,8	254,3	9,6	277,4	11,2
		38	23,5	7,6	178,6	9,5	223,3	10,5	246,8	11,4	267,9	13,7
		44	19,6	8,8	172,5	11,0	215,6	12,1	237,2	13,2	258,7	15,7
		51	17,3	10,2	176,5	12,8	221,4	14,0	242,2	15,3	264,7	18,8
		64	13,5	12,8	172,8	16,0	216,0	17,6	237,6	19,2	259,2	23,6
		76	11,2	15,2	170,2	19,0	212,8	20,9	234,1	22,8	255,4	28,4
		89	9,5	17,8	169,1	22,3	211,9	24,5	232,8	26,7	253,7	33,0
2,2		305	2,7	61,0	164,7	76,3	206,0	83,9	226,5	91,5	247,1	114,0
16	8	25	81,6	5,0	408,0	6,3	514,1	6,9	563,0	7,5	612,0	9,1
		32	61,3	6,4	392,3	8,0	490,4	8,8	539,4	9,6	588,5	11,4
		38	49,9	7,6	379,2	9,5	474,1	10,5	524,0	11,4	568,9	14,2
		44	40,8	8,8	359,0	11,0	448,8	12,1	493,7	13,2	538,6	16,3
		51	35,6	10,2	363,1	12,8	455,7	14,0	498,4	15,3	544,7	18,8
		64	27,8	12,8	355,8	16,0	444,8	17,6	489,3	19,2	533,8	23,9
		76	22,8	15,2	346,6	19,0	433,2	20,9	476,5	22,8	519,8	29,0
		89	19,6	17,8	348,9	22,3	437,1	24,5	480,2	26,7	523,3	34,3
		102	17,0	20,4	346,8	25,5	433,5	28,1	477,7	30,6	520,2	39,4
2,8		305	5,4	61,0	329,4	76,3	412,0	83,9	453,1	91,5	494,1	119,0

Forma de pedido: RNTR + D1 * L
How to order: RNTR + D1 * L

MUELLE REDONDO CON LUBRICACIÓN ANTIÓXIDO RNL

ROUND SPRINGS WITH ANTI-RUST LUBRICANT RNL

STOCK

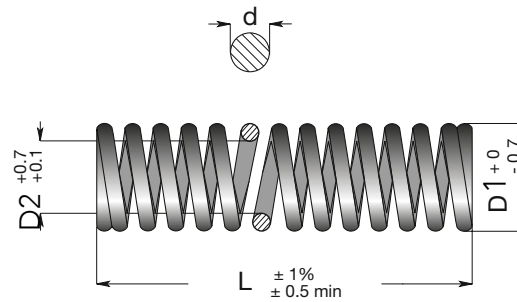

RNL

D1	D2	L	R	A	B	C	D				
Diámetro exterior Outside diameter	Diámetro interior Inside diameter	Longitud libre Free length	Constante elástica ±10 Spring constant ±10	16% L	24% L	28% L	32% L				
d			±10%	+ 3.000.000	~ 1.500.000	300 - 500.00	100 - 200.00				
mm	mm	mm	N/mm	mm	N	mm	N				
3	2	10	2,94	1,6	4,4	2,4	6,62	2,8	6,9	3,2	8,8
		15	1,96	2,4	4,4	3,6	6,62	4,2	6,9	4,8	8,8
		20	0,98	3,2	4,4	4,8	6,62	5,6	6,9	6,4	8,8
0,4		25	0,98	4,0	4,4	6,0	6,62	7,0	6,9	8,0	8,8
4	2,6	10	4,9	1,6	7,8	2,4	11,6	2,8	14,5	3,2	15,7
		15	2,94	2,4	7,8	3,6	11,6	4,2	14,5	4,8	15,7
		20	2,94	3,2	7,8	4,8	11,6	5,6	14,5	6,4	15,7
		25	1,96	4,0	7,8	6,0	11,6	7,0	14,5	8,0	15,7
0,6		30	1,96	4,8	7,8	7,2	11,6	8,4	14,5	9,6	15,7
6	4	15	7,85	2,4	17,7	3,6	26,5	4,2	32,4	4,8	35,5
		20	5,88	3,2	17,7	4,8	26,5	5,6	32,4	6,4	35,5
		25	4,90	4,0	17,7	6,0	26,5	7,0	32,4	8,0	35,5
		30	3,92	4,8	17,7	7,2	26,5	8,4	32,4	9,6	35,5
0,9		35	2,94	5,6	17,7	8,4	26,5	9,8	32,4	11,2	35,5
8	5,4	20	9,81	3,2	31,4	4,8	47,1	5,6	55,6	6,4	62,8
		25	7,85	4,0	31,4	6,0	47,1	7,0	55,6	8,0	62,8
		30	6,86	4,8	31,4	7,2	47,1	8,4	55,6	9,6	62,8
		35	5,88	5,6	31,4	8,4	47,1	9,8	55,6	11,2	62,8
1,2		40	4,90	6,4	31,4	9,6	47,1	11,2	55,6	12,8	62,8
10	6,5	25	12,75	4,0	49	6,0	73,6	7,0	85,8	8,0	98
		30	9,81	4,8	49	7,2	73,6	8,4	85,8	9,6	98
		35	8,83	5,6	49	8,4	73,6	9,8	85,8	11,2	98
		40	7,85	6,4	49	9,6	73,6	11,2	85,8	12,8	98
		45	6,86	7,2	49	10,8	73,6	12,6	85,8	14,4	98
1,5		50	5,88	8,0	49	12,0	73,6	14,0	85,8	16,0	98
12	8	25	17,65	4,0	70,6	6,0	106,9	7,0	124,1	8,0	141,2
		30	14,71	4,8	70,6	7,2	106,9	8,4	124,1	9,6	141,2
		35	12,75	5,6	70,6	8,4	106,9	9,8	124,1	11,2	141,2
		40	10,79	6,4	70,6	9,6	106,9	11,2	124,1	12,8	141,2





Continúa en la siguiente página...
Continue next page...

Forma de pedido: RNL + D1 * L
How to order: RNL + D1 * L

MUELLE REDONDO CON LUBRICACIÓN ANTIÓXIDO RNL

ROUND SPRINGS WITH ANTI-RUST LUBRICANT RNL





RNL

D1	D2	L	R		A		B		C		D
Diámetro exterior Outside diameter	Diámetro interior Inside diameter	Longitud libre Free length	Constante elástica ±10 Spring constant ±10		16% L		24% L		28% L		32% L
d		±10%		+ 3.000.000		~ 1.500.000		300 - 500.00		100 - 200.00	
mm	mm	mm	N/mm	mm	N	mm	N	mm	N	mm	N
12	8	45	9,81	7,2	70,6	10,8	106,9	12,6	124,1	14,4	141,2
		50	8,83	8,0	70,6	12,0	106,9	14,0	124,1	16,0	141,2
		55	7,85	8,8	70,6	13,2	106,9	15,4	124,1	17,6	141,2
1,8		60	7,85	9,6	70,6	14,4	106,9	16,8	124,1	19,2	141,2
14	9,3	25	24,52	4,0	96,1	6,0	144,2	7,0	167,7	8,0	192,2
		30	19,61	4,8	96,1	7,2	144,2	8,4	167,7	9,4	192,2
		35	17,65	5,6	96,1	8,4	144,2	9,8	167,7	11,2	192,2
		40	14,71	6,4	96,1	9,6	144,2	11,2	167,7	12,8	192,2
		45	13,73	7,2	96,1	10,8	144,2	12,6	167,7	14,4	192,2
		50	11,77	8,0	96,1	12,0	144,2	14,0	167,7	16,0	192,2
		55	10,79	8,8	96,1	13,2	144,2	15,4	167,7	17,6	192,2
		60	9,81	9,6	96,1	14,4	144,2	16,8	167,7	19,2	192,2
65	8,83	10,4	96,1	15,6	144,2	18,2	167,7	20,8	192,2		
2,2		70	8,83	11,2	96,1	16,8	144,2	19,6	167,7	22,4	192,2
16	10,7	25	31,38	4,0	125,5	6,0	188,3	7,0	219,8	8,0	251,1
		30	26,48	4,8	125,5	7,2	188,3	8,4	219,8	9,4	251,1
		35	22,56	5,6	125,5	8,4	188,3	9,8	219,8	11,2	251,1
		40	19,61	6,4	125,5	9,6	188,3	11,2	219,8	12,8	251,1
		45	17,65	7,2	125,5	10,8	188,3	12,6	219,8	14,4	251,1
		50	15,69	8,0	125,5	12,0	188,3	14,0	219,8	16,0	251,1
		55	14,71	8,8	125,5	13,2	188,3	15,4	219,8	17,6	251,1
		60	12,75	9,6	125,5	14,4	188,3	16,8	219,8	19,2	251,1
		65	11,77	10,4	125,5	15,6	188,3	18,2	219,8	20,8	251,1
		70	10,79	11,2	125,5	16,8	188,3	19,6	219,8	22,4	251,1
75	10,79	12,0	125,5	18,0	188,3	21,0	219,8	24,0	251,1		
2,4		80	9,81	12,8	125,5	19,2	188,3	22,4	219,8	25,6	251,1
18	12	25	40,21	4,0	158,9	6,0	238,3	7,0	280,4	8,0	317,7
		30	33,34	4,8	158,9	7,2	238,3	8,4	280,4	9,4	317,7
		35	28,44	5,6	158,9	8,4	238,3	9,8	280,4	11,2	317,7
		40	24,52	6,4	158,9	9,6	238,3	11,2	280,4	12,8	317,7
		45	22,56	7,2	158,9	10,8	238,3	12,6	280,4	14,4	317,7
		50	19,61	8,0	158,9	12,0	238,3	14,0	280,4	16,0	317,7
		55	17,65	8,8	158,9	13,2	238,3	15,4	280,4	17,6	317,7
		60	16,67	9,6	158,9	14,4	238,3	16,8	280,4	19,2	317,7
		65	15,69	10,4	158,9	15,6	238,3	18,2	280,4	20,8	317,7
		70	14,71	11,2	158,9	16,8	238,3	19,6	280,4	22,4	317,7
		75	13,73	12,0	158,9	18,0	238,3	21,0	280,4	24,0	317,7
		80	12,75	12,8	158,9	19,2	238,3	22,4	280,4	25,6	317,7
2,8		90	10,79	14,4	158,9	21,6	238,3	25,2	280,4	28,8	317,7

Continúa en la siguiente página...
Continue next page...

Forma de pedido: RNL + D1 * L
How to order: RNL + D1 * L





RNL

D1	D2	L	R	A		B		C		D	
Diámetro exterior Outside diameter	Diámetro interior Inside diameter	Longitud libre Free length	Constante elástica ±10 Spring constant ±10		16% L		24% L		28% L		32% L
d			±10%	+ 3.000.000		- 1.500.000		300 - 500.00		100 - 200.00	
mm	mm	mm	N/mm	mm	N	mm	N	mm	N	mm	N
20	13,5	25	49,03	4,0	196,1	6,0	294,2	7,0	346,3	8,0	392,3
		30	41,19	4,8	196,1	7,2	294,2	8,4	346,3	9,4	392,3
		35	35,3	5,6	196,1	8,4	294,2	9,8	346,3	11,2	392,3
		40	30,4	6,4	196,1	9,6	294,2	11,2	346,3	12,8	392,3
		45	27,46	7,2	196,1	10,8	294,2	12,6	346,3	14,4	392,3
		50	24,52	8,0	196,1	12,0	294,2	14,0	346,3	16,0	392,3
		55	22,56	8,8	196,1	13,2	294,2	15,4	346,3	17,6	392,3
		60	20,59	9,6	196,1	14,4	294,2	16,8	346,3	19,2	392,3
		65	18,63	10,4	196,1	15,6	294,2	18,2	346,3	20,8	392,3
		70	17,65	11,2	196,1	16,8	294,2	19,6	346,3	22,4	392,3
		75	16,67	12,0	196,1	18,0	294,2	21,0	346,3	24,0	392,3
80	15,69	12,8	196,1	19,2	294,2	22,4	346,3	25,6	392,3		
90	13,73	14,4	196,1	21,6	294,2	25,2	346,3	28,8	392,3		
3		100	12,75	16,0	196,1	24,0	294,2	28,0	346,3	32,0	392,3
22	14,7	25	5982	4,0	237,3	6,0	356	7,0	415,9	8,0	474,6
		30	49,03	4,8	237,3	7,2	356	8,4	415,9	9,4	474,6
		35	42,17	5,6	237,3	8,4	356	9,8	415,9	11,2	474,6
		40	37,27	6,4	237,3	9,6	356	11,2	415,9	12,8	474,6
		45	33,34	7,2	237,3	10,8	356	12,6	415,9	14,4	474,6
		50	29,42	8,0	237,3	12,0	356	14,0	415,9	16,0	474,6
		55	27,46	8,8	237,3	13,2	356	15,4	415,9	17,6	474,6
		60	24,52	9,6	237,3	14,4	356	16,8	415,9	19,2	474,6
		65	22,56	10,4	237,3	15,6	356	18,2	415,9	20,8	474,6
		70	21,57	11,2	237,3	16,8	356	19,6	415,9	22,4	474,6
		75	19,61	12,0	237,3	18,0	356	21,0	415,9	24,0	474,6
80	18,63	12,8	237,3	19,2	356	22,4	415,9	25,6	474,6		
90	16,67	14,4	237,3	21,6	356	25,2	415,9	28,8	474,6		
3,4		100	14,71	16,0	237,3	24,0	356	28,0	415,9	32,0	474,6
25	17	25	76,49	4,0	307	6,0	459,9	7,0	537,9	8,0	613,9
		30	63,74	4,8	307	7,2	459,9	8,4	537,9	9,4	613,9
		35	54,92	5,6	307	8,4	459,9	9,8	537,9	11,2	613,9
		40	48,05	6,4	307	9,6	459,9	11,2	537,9	12,8	613,9
		45	42,17	7,2	307	10,8	459,9	12,6	537,9	14,4	613,9
		50	38,25	8,0	307	12,0	459,9	14,0	537,9	16,0	613,9
		55	35,30	8,8	307	13,2	459,9	15,4	537,9	17,6	613,9
		60	32,36	9,6	307	14,4	459,9	16,8	537,9	19,2	613,9
		65	29,42	10,4	307	15,6	459,9	18,2	537,9	20,8	613,9
		70	27,46	11,2	307	16,8	459,9	19,6	537,9	22,4	613,9
		75	25,50	12,0	307	18,0	459,9	21,0	537,9	24,0	613,9
80	23,54	12,8	307	19,2	459,9	22,4	537,9	25,6	613,9		
90	21,57	14,4	307	21,6	459,9	25,2	537,9	28,8	613,9		
3,8		100	19,61	16,0	307	24,0	459,9	28,0	537,9	32,0	613,9

Continúa en la siguiente página...
 Continue next page...

Forma de pedido: RNL + D1 * L
 How to order: RNL + D1 * L

RNL

D1	D2	L	R	A	B	C	D				
Diámetro exterior Outside diameter	Diámetro interior Inside diameter	Longitud libre Free length	Constante elástica ± 10 Spring constant ± 10	 16% L	 24% L	 28% L	 32% L				
d			$\pm 10\%$	+ 3.000.000	~ 1.500.000	300 - 500.00	100 - 200.00				
mm	mm	mm	N/mm	mm	N	mm	N				
30	20	50	51,94	8,0	414	12,0	621	14,0	724,1	16,0	828
		60	44,10	9,6	414	14,4	621	16,8	724,1	19,2	828
		70	37,24	11,2	414	16,6	621	19,6	724,1	22,4	828
		80	32,34	12,8	414	19,2	621	22,4	724,1	25,6	828
		90	28,42	14,4	414	21,6	621	25,2	724,1	28,8	828
		100	25,48	16,0	414	24,0	621	28,0	724,1	32,0	828
4,5		125	20,58	20,0	414	30,0	621	35,0	724,1	40,0	828

Forma de pedido: RNL + D1 * L
How to order: RNL + D1 * L

MUELLE REDONDO COMPRESIÓN SIN EXTREMOS REFRENTADOS RNL LONG SIZE ROUND SPRINGS OPEN ENDS RNL

STOCK

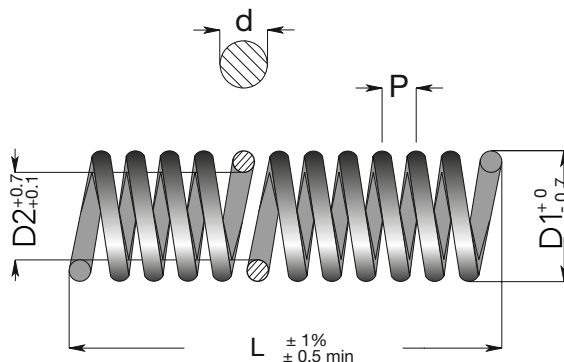

RNL

D1	D2	d	L	P
Diámetro exterior Outside diameter	Diámetro interior Inside diameter	Diámetro del hilo Wire diameter	Longitud del muelle Spring free length	Paso Pitch
mm	mm	mm	mm	mm
3	2,0	0,4	300	1,04
4	2,6	0,6	300	1,50
6	4,0	0,9	300	2,00
8	5,4	1,2	300	2,80
10	6,5	1,5	300	3,50
12	8,0	1,8	300	4,30
14	9,3	2,2	300	4,80
16	10,7	2,4	300	5,50
18	12,0	2,8	300	5,30
20	13,5	3,0	300	6,80
22	14,7	3,4	300	6,70
25	17,0	3,8	300	8,20

Forma de pedido: RNL + D1 * L
How to order: RNL + D1 * L

MUELLE OVALADO CARGA LIGERA ROB
LIGHT LOAD OVAL SPRINGS ROB

STOCK

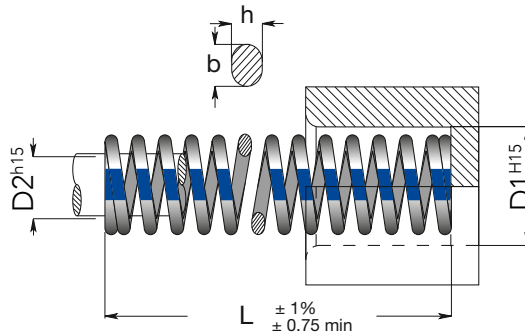

ROB

Norma / Standard: US standard

D1	D2	L	R	A	B	C	D	E				
Diámetro del alojamiento Hole diameter	Diámetro de la guía Spring inside diameter	Longitud libre Free length	Constante elástica ±10 Spring constant ±10	25% L	40% L	45% L	50% L	aprox. no usar aprox. do not use				
b x h			±10%	+ 3.000.000	~ 1.500.000	300 - 500.00	100 - 200.00					
mm	mm	mm	N/mm	mm N	mm N	mm N	mm N	mm				
9,5	4,7	25	14,4	6,3	90,7	10,0	144,0	11,3	162,7	12,5	180,0	13,5
		32	12,3	8,0	98,4	12,8	157,4	14,4	177,1	16,0	196,8	17,5
		38	9,8	9,5	93,1	15,2	149,0	17,1	167,6	19,0	186,2	20,8
		44	8,8	11,0	96,8	17,6	154,9	19,8	174,2	22,0	193,6	23,9
		51	7,5	12,8	96,0	20,4	153,0	23,0	172,5	25,5	191,3	28,9
		64	4,9	16,0	78,4	25,6	125,4	28,8	141,1	32,0	156,8	36,1
		76	3,8	19,0	72,2	30,4	115,5	34,2	130,0	38,0	144,4	43,2
1,96 x 1,00		305	1,2	76,3	91,6	122,0	146,4	137,3	164,8	152,5	183,0	178,7
13	7	25	18,9	6,3	119,1	10,0	189,0	11,3	213,6	12,5	236,3	13,2
		32	15,4	8,0	123,2	12,8	197,1	14,4	221,8	16,0	246,4	18,0
		38	13,5	9,5	128,3	15,2	205,2	17,1	230,9	19,0	256,5	21,0
		44	11,8	11,0	129,8	17,6	207,7	19,8	233,6	22,0	259,6	24,0
		51	10,0	12,8	128,0	20,4	204,0	23,0	230,0	25,5	255,0	28,7
		64	7,6	16,0	121,6	25,6	194,6	28,8	218,9	32,0	243,2	35,8
		76	5,9	19,0	112,1	30,4	179,4	34,2	201,8	38,0	224,2	42,7
		89	4,8	22,3	107,0	35,6	170,9	40,1	192,5	44,5	213,6	50,4
102	3,4	25,5	86,7	40,8	138,7	45,9	156,1	51,0	173,4	58,4		
2,50 x 1,46		305	1,6	76,3	122,1	122,0	195,2	137,3	219,7	152,5	244,0	172,0
16	8,7	25	22,9	6,3	144,3	10,0	229,0	11,3	258,8	12,5	286,3	12,7
		32	22,5	8,0	180,0	12,8	288,0	14,4	324,0	16,0	360,0	16,6
		38	18,9	9,5	179,6	15,2	287,3	17,1	323,2	19,0	359,1	20,0
		44	16,8	11,0	184,8	17,6	295,7	19,8	332,6	22,0	369,6	23,4
		51	15,4	12,8	197,1	20,4	314,2	23,0	354,2	25,5	392,7	26,8
		64	10,5	16,0	168,0	25,6	268,8	28,8	302,4	32,0	336,0	33,2
		76	9,8	19,0	186,2	30,4	297,9	34,2	335,2	38,0	372,4	41,8
		89	8,4	22,3	187,3	35,6	299,0	40,1	336,8	44,5	373,8	48,6
		102	7,7	25,5	196,4	40,8	314,2	45,9	353,4	51,0	392,7	55,5
		115	5,9	28,8	169,9	46,0	271,4	51,8	305,6	57,5	339,3	62,2
2,80 x 1,88		305	2,5	76,3	190,8	122,0	305,0	137,3	343,3	152,5	381,3	170,9











Continúa en la siguiente página...
 Continue next page...

Forma de pedido: ROB + D1 * L
 How to order: ROB + D1 * L

MUELLE OVALADO CARGA LIGERA ROB

LIGHT LOAD OVAL SPRINGS ROB

ROB





D1	D2	L	R		A		B		C		D		E
Diámetro del alojamiento Hole diameter	Diámetro de la guía Spring inside diameter	Longitud libre Free length	Constante elástica ±10 Spring constant ±10		25% L		40% L		45% L		50% L		 aprox. no usar aprox. do not use
b x h			±10%		+ 3.000.000		~ 1.500.000		300 - 500.00		100 - 200.00		
mm	mm	mm	N/mm	mm	N	mm	N	mm	N	mm	N	mm	mm
19,5	9,5	25	53,0	6,3	333,9	10,0	530,0	11,3	598,9	12,5	662,5	12,7	
		32	43,1	8,0	344,8	12,8	551,7	14,4	620,6	16,0	689,6	17,0	
		38	34,3	9,5	325,9	15,2	521,4	17,1	586,5	19,0	651,7	20,3	
		44	30,4	11,0	334,4	17,6	535,0	19,8	601,9	22,0	668,8	23,5	
		51	25,5	12,8	326,4	20,4	520,2	23,0	586,5	25,5	650,3	27,4	
		64	20,6	16,0	329,6	25,6	527,4	28,8	593,3	32,0	659,2	34,7	
		76	16,2	19,0	307,8	30,4	492,5	34,2	554,0	38,0	615,6	42,4	
		89	14,2	22,3	316,7	35,6	505,5	40,1	569,4	44,5	631,9	48,9	
		102	12,2	25,5	311,1	40,8	497,8	45,9	560,0	51,0	622,2	56,6	
		115	11,0	28,8	316,8	46,0	506,0	51,8	569,8	57,5	632,5	64,1	
		127	9,8	31,8	311,6	50,8	497,8	57,2	560,6	63,5	622,3	71,7	
		140	8,3	35,0	290,5	56,0	464,8	63,0	522,9	70,0	581,0	79,8	
152	7,2	38,0	273,6	60,8	437,8	68,4	492,5	76,0	547,2	85,9			
4,00 x 2,00		305	4,1	76,3	312,8	122,0	500,2	137,3	562,9	152,5	625,3	167,8	
25,5	13	25	107,9	6,3	680	10,0	1079	11,3	1219	12,5	1349	12,6	
		32	80,4	8,0	643	12,8	1029	14,4	1158	16,0	1286	16,1	
		38	62,8	9,5	597	15,2	955	17,1	1074	19,0	1193	19,1	
		44	52,0	11,0	572	17,6	915	19,8	1030	22,0	1144	22,9	
		51	43,1	12,8	552	20,4	879	23,0	991	25,5	1099	27,3	
		64	35,3	16,0	565	25,6	904	28,8	1017	32,0	1130	33,3	
		76	29,4	19,0	559	30,4	894	34,2	1005	38,0	1117	39,5	
		89	24,5	22,3	546	35,6	872	40,1	982	44,5	1090	47,7	
		102	21,6	25,5	551	40,8	881	45,9	991	51,0	1102	56,4	
		115	18,6	28,8	536	46,0	856	51,8	963	57,5	1070	62,2	
		127	17,2	31,8	547	50,8	874	57,2	984	63,5	1092	69,4	
		140	15,7	35,0	550	56,0	879	63,0	989	70,0	1099	76,9	
		152	14,7	38,0	559	60,8	894	68,4	1005	76,0	1117	83,0	
		178	12,7	44,5	565	71,2	904	80,1	1017	89,0	1130	98,6	
203	10,8	50,8	549	81,2	877	91,4	987	101,5	1096	111,9			
5,50 x 2,50		305	7,4	76,3	565	122,0	903	137,3	1016	152,5	1129	165,4	
32	16	38	88,3	9,5	839	15,2	1342	17,1	1510	19,0	1678	19,2	
		44	76,5	11,0	842	17,6	1346	19,8	1515	22,0	1683	22,4	
		51	60,8	12,8	778	20,4	1240	23,0	1398	25,5	1550	25,8	
		64	49,0	16,0	784	25,6	1254	28,8	1411	32,0	1568	33,1	
		76	41,2	19,0	783	30,4	1252	34,2	1409	38,0	1566	39,9	
		89	35,3	22,3	787	35,6	1257	40,1	1416	44,5	1571	47,1	
		102	30,4	25,5	775	40,8	1240	45,9	1395	51,0	1550	54,4	
		115	27,5	28,8	792	46,0	1265	51,8	1425	57,5	1581	61,1	
		127	23,5	31,8	747	50,8	1194	57,2	1344	63,5	1492	68,2	
140	21,6	35,0	756	56,0	1210	63,0	1361	70,0	1512	75,7			

Continúa en la siguiente página...
Continue next page...

Forma de pedido: ROB + D1 * L
How to order: ROB + D1 * L

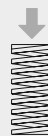
MUELLE OVALADO CARGA LIGERA ROB
LIGHT LOAD OVAL SPRINGS ROB

ROB

D1	D2	L	R	A	B	C	D	E				
Diámetro del alojamiento Hole diameter	Diámetro de la guía Spring inside diameter	Longitud libre Free length	Constante elástica ±10 Spring constant ±10	 25% L	 40% L	 45% L	 50% L	 <small>aprox. no usar aprox. do not use</small>				
b x h			±10%	+ 3.000.000	- 1.500.000	300 - 500.00	100 - 200.00					
mm	mm	mm	N/mm	mm N	mm N	mm N	mm N	mm				
32	16	152	19,6	38,0	745	60,8	1192	68,4	1341	76,0	1490	82,3
		178	17,7	44,5	788	71,2	1260	80,1	1418	89,0	1575	97,3
		203	14,4	50,8	732	81,2	1169	91,4	1316	101,5	1462	110,2
		254	12,7	63,5	806	101,6	1290	114,3	1452	127,0	1613	137,9
6,90 x 3,00		305	9,8	76,3	748	122,0	1196	137,3	1346	152,5	1495	163,8
38,5	19,5	51	71,4	12,8	914	20,4	1457	23,0	1642	25,5	1821	26,3
		64	62,8	16,0	1005	25,6	1608	28,8	1809	32,0	2010	33,1
		76	51,0	19,0	969	30,4	1550	34,2	1744	38,0	1938	39,9
		89	43,1	22,3	961	35,6	1534	40,1	1728	44,5	1918	47,4
		102	36,3	25,5	926	40,8	1481	45,9	1666	51,0	1851	54,7
		115	32,4	28,8	933	46,0	1490	51,8	1678	57,5	1863	61,4
		127	29,4	31,8	935	50,8	1494	57,2	1682	63,5	1867	68,1
		140	27,0	35,0	945	56,0	1512	63,0	1701	70,0	1890	76,8
		152	24,5	38,0	931	60,8	1490	68,4	1676	76,0	1862	82,5
		178	21,6	44,5	961	71,2	1538	80,1	1730	89,0	1922	97,9
		203	18,6	50,8	945	81,2	1510	91,4	1700	101,5	1888	110,3
254	14,7	63,5	933	101,6	1494	114,3	1680	127,0	1867	140,0		
8,00 x 3,50		305	10,8	76,3	824	122,0	1318	137,3	1483	152,5	1647	164,1
51	25,5	64	156,9	16,0	2510	25,6	4017	28,8	4519	32,0	5021	32,1
		76	132,4	19,0	2516	30,4	4025	34,2	4528	38,0	5031	41,2
		89	114,7	22,3	2558	35,6	4083	40,1	4599	44,5	5104	48,1
		102	98,1	25,5	2502	40,8	4002	45,9	4503	51,0	5003	54,7
		115	87,3	28,8	2514	46,0	4016	51,8	4522	57,5	5020	62,2
		127	77,5	31,8	2465	50,8	3937	57,2	4433	63,5	4921	69,4
		140	69,6	35,0	2436	56,0	3898	63,0	4385	70,0	4872	76,8
		152	64,7	38,0	2459	60,8	3934	68,4	4425	76,0	4917	81,9
		178	53,0	44,5	2359	71,2	3774	80,1	4245	89,0	4717	98,1
		203	47,1	50,8	2393	81,2	3825	91,4	4305	101,5	4781	112,5
		254	37,5	63,5	2381	101,6	3810	114,3	4286	127,0	4763	141,2
11,50 x 5,00		305	31,4	76,3	2396	122,0	3831	137,3	4311	152,5	4789	169,9
63	38	76	189,3	19,0	3597	30,4	5755	34,2	6474	38,0	7193	38,4
		89	156,9	22,3	3499	35,6	5586	40,1	6292	44,5	6982	46,0
		102	133,4	25,5	3402	40,8	5443	45,9	6123	51,0	6803	52,8
		115	116,7	28,8	3361	46,0	5368	51,8	6045	57,5	6710	59,7
		127	104,0	31,8	3307	50,8	5283	57,2	5949	63,5	6604	67,4
		140	93,1	35,0	3259	56,0	5214	63,0	5865	70,0	6517	74,7
		152	84,3	38,0	3203	60,8	5125	68,4	5766	76,0	6407	81,9
		178	72,6	44,5	3231	71,2	5169	80,1	5815	89,0	6461	98,5
		203	62,8	50,8	3190	81,2	5099	91,4	5740	101,5	6374	109,1
		254	47,1	63,5	2991	101,6	4785	114,3	5384	127,0	5982	140,2
		11,76 x 7,20		305	38,2	76,3	2915	122,0	4660	137,3	5245	152,5

Forma de pedido: ROMBL + D1 * L
How to order: ROMBL + D1 * L

MUELLE OVALADO CARGA MEDIA ROR

MEDIUM LOAD OVAL SPRINGS ROR

STOCK

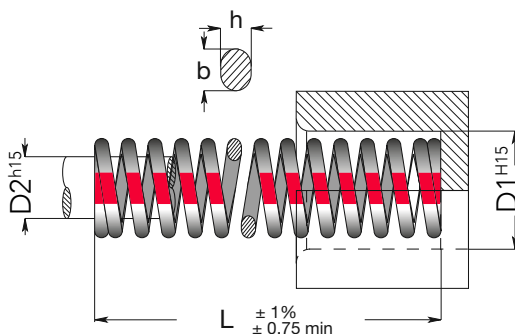

ROR

Norma / Standard: US standard

D1	D2	L	R	A	B	C	D	E				
Diámetro del alojamiento Hole diameter	Diámetro de la guía Spring inside diameter	Longitud libre Free length	Constante elástica ±10 Spring constant ±10	20% L	25% L	31% L	37% L	aprox. no usar aprox. do not use				
b x h			±10%	+ 3.000.000	~ 1.500.000	300 - 500.00	100 - 200.00					
mm	mm	mm	N/mm	mm N	mm N	mm N	mm N	mm				
9,5	4,7	25	17,7	5,0	88,5	6,3	111,5	7,8	138,1	9,3	164,6	10,2
		32	15,2	6,4	97,3	8,0	121,6	9,9	150,5	11,8	179,4	14,2
		38	13,2	7,6	100,3	9,5	125,4	11,8	155,8	14,1	186,1	16,8
		44	11,3	8,8	99,4	11,0	124,3	13,6	153,7	16,3	184,2	19,4
		51	8,4	10,2	85,7	12,8	107,5	15,8	132,7	18,9	158,8	23,4
		64	7,2	12,8	92,2	16,0	115,2	19,8	142,6	23,7	170,6	28,2
		76	5,8	15,2	88,2	19,0	110,2	23,6	136,9	28,1	163,0	34,2
1,90 x 1,30		305	1,5	61,0	91,5	76,3	114,5	94,6	141,9	112,9	169,4	133,8
13	7	25	30,4	5,0	152,0	6,3	191,5	7,8	237,1	9,3	282,7	11,9
		32	22,1	6,4	141,4	8,0	176,8	9,9	218,8	11,8	260,8	16,2
		38	19,1	7,6	145,2	9,5	181,5	11,8	225,4	14,1	269,3	18,7
		44	16,1	8,8	141,7	11,0	177,1	13,6	219,0	16,3	262,4	21,3
		51	15,0	10,2	153,0	12,8	192,0	15,8	237,0	18,9	283,5	25,6
		64	11,8	12,8	151,0	16,0	188,8	19,8	233,6	23,7	279,7	32,4
		76	9,8	15,2	149,0	19,0	186,2	23,6	231,3	28,1	275,4	39,0
		89	8,1	17,8	144,2	22,3	180,6	27,6	223,6	32,9	266,5	45,9
2,50 x 1,50		305	2,1	61,0	128,1	76,3	160,2	94,6	198,7	112,9	237,1	152,5
16	8,7	25	56,8	5,0	284,0	6,3	357,8	7,8	443,0	9,3	528,2	10,5
		32	38,2	6,4	244,5	8,0	305,6	9,9	378,2	11,8	450,8	13,2
		38	33,3	7,6	253,1	9,5	316,4	11,8	392,9	14,1	469,5	17,2
		44	29,2	8,8	257,0	11,0	321,2	13,6	397,1	16,3	476,0	19,4
		51	25,5	10,2	260,1	12,8	326,4	15,8	402,9	18,9	482,0	24,2
		64	19,6	12,8	250,9	16,0	313,6	19,8	388,1	23,7	464,5	29,2
		76	16,2	15,2	246,2	19,0	307,8	23,6	382,3	28,1	455,2	36,3
		89	13,7	17,8	243,9	22,3	305,5	27,6	378,1	32,9	450,7	41,7
		102	12,7	20,4	259,1	25,5	323,9	31,6	401,3	37,7	478,8	48,9
		115	10,3	23,0	236,9	28,8	296,6	35,7	367,7	42,6	438,8	53,1
3,20 x 2,00		305	3,9	61,0	237,9	76,3	297,6	94,6	368,9	112,9	440,3	141,6

Continúa en la siguiente página...
Continue next page...

Forma de pedido: ROR + D1 * L
How to order: ROR + D1 * L

MUELLE OVALADO CARGA MEDIA ROR MEDIUM LOAD OVAL SPRINGS ROR



D1	D2	L	R	A		B		C		D		E
Diámetro del alojamiento Hole diameter	Diámetro de la guía Spring inside diameter	Longitud libre Free length	Constante elástica ±10 Spring constant ±10		20% L		25% L		31% L		37% L	
b x h			±10%	+ 3.000.000		- 1.500.000		300 - 500.00		100 - 200.00		
mm	mm	mm	N/mm	mm	N	mm	N	mm	N	mm	N	mm
19,5	9,5	25	99,0	5,0	495,0	6,3	623,7	7,8	772,2	9,3	920,7	10,8
		32	77,5	6,4	496,0	8,0	620,0	9,9	767,3	11,8	914,5	13,9
		38	55,9	7,6	424,8	9,5	531,1	11,8	659,6	14,1	788,2	17,1
		44	50,0	8,8	440,0	11,0	550,0	13,6	680,0	16,3	815,0	19,6
		51	42,2	10,2	430,4	12,8	540,2	15,8	666,8	18,9	797,6	22,4
		64	33,3	12,8	426,2	16,0	532,8	19,8	659,3	23,7	789,2	28,5
		76	25,0	15,2	380,0	19,0	475,0	23,6	590,0	28,1	702,5	33,5
		89	23,1	17,8	411,2	22,3	515,1	27,6	637,6	32,9	760,0	40,2
		102	20,6	20,4	420,2	25,5	525,3	31,6	651,0	37,7	776,6	45,5
		115	18,6	23,0	427,8	28,8	535,7	35,7	664,0	42,6	792,4	50,3
		127	17,7	25,4	449,6	31,8	562,9	39,4	697,4	47,0	831,9	56,6
		140	16,2	28,0	453,6	35,0	567,0	43,4	703,1	51,8	839,2	61,9
		152	13,9	30,4	422,6	38,0	528,2	47,1	654,7	56,2	781,2	67,6
4,00 x 2,40		305	6,4	61,0	390,4	76,3	488,3	94,6	605,4	112,9	722,6	136,3
25,5	13	25	137,3	5,0	687	6,3	865	7,8	1071	9,3	1277	9,9
		32	105,9	6,4	678	8,0	847	9,9	1048	11,8	1250	13,3
		38	88,3	7,6	671	9,5	839	11,8	1042	14,1	1245	16,5
		44	76,5	8,8	673	11,0	842	13,6	1040	16,3	1247	19,3
		51	63,7	10,2	650	12,8	815	15,8	1006	18,9	1204	22,0
		64	49,0	12,8	627	16,0	784	19,8	970	23,7	1161	27,4
		76	41,7	15,2	634	19,0	792	23,6	984	28,1	1172	32,8
		89	35,8	17,8	637	22,3	798	27,6	988	32,9	1178	39,0
		102	31,9	20,4	651	25,5	813	31,6	1008	37,7	1203	44,7
		115	27,0	23,0	621	28,8	778	35,7	964	42,6	1150	49,8
		127	24,5	25,4	622	31,8	779	39,4	965	47,0	1152	56,3
		140	22,6	28,0	633	35,0	791	43,4	981	51,8	1171	63,0
		152	19,6	30,4	598	38,0	745	47,1	923	56,2	1102	66,2
		178	17,7	35,6	630	44,5	788	55,2	977	65,9	1166	77,9
203	15,7	40,6	637	50,8	798	62,9	988	75,1	1179	88,5		
5,50 x 3,00		305	10,8	61,0	659	76,3	824	94,6	1022	112,9	1219	136,6
32	16	38	196,1	7,6	1490	9,5	1863	11,8	2314	14,1	2765	16,1
		44	176,5	8,8	1553	11,0	1942	13,6	2400	16,3	2877	18,5
		51	147,1	10,2	1500	12,8	1883	15,8	2324	18,9	2780	21,4
		64	107,9	12,8	1381	16,0	1726	19,8	2136	23,7	2557	27,4
		76	90,2	15,2	1371	19,0	1714	23,6	2129	28,1	2535	32,7
		89	74,5	17,8	1326	22,3	1661	27,6	2056	32,9	2451	39,1
		102	64,7	20,4	1320	25,5	1650	31,6	2045	37,7	2439	43,4
		115	55,9	23,0	1286	28,8	1610	35,7	1996	42,6	2381	49,7
		127	47,1	25,4	1196	31,8	1498	39,4	1856	47,0	2214	54,1
		140	44,1	28,0	1235	35,0	1544	43,4	1914	51,8	2284	60,0
		152	40,7	30,4	1237	38,0	1547	47,1	1917	56,2	2287	66,8

Continúa en la siguiente página...
Continue next page...





Forma de pedido: ROR + D1 * L
How to order: ROR + D1 * L

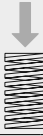

MUELLE OVALADO CARGA MEDIA ROR

MEDIUM LOAD OVAL SPRINGS ROR

ROR

D1	D2	L	R		A		B		C		D		E
Diámetro del alojamiento Hole diameter	Diámetro de la guía Spring inside diameter	Longitud libre Free length	Constante elástica ±10 Spring constant ±10		20% L		25% L		31% L		37% L		aprox. no usar aprox. do not use
b x h			±10%	+ 3.000.000		~ 1.500.000		300 - 500.00		100 - 200.00			
mm	mm	mm	N/mm	mm	N	mm	N	mm	N	mm	N	mm	mm
32	16	178	34,3	35,6	1221	44,5	1526	55,2	1893	65,9	2260	78,2	
		203	31,4	40,6	1275	50,8	1595	62,9	1975	75,1	2358	87,2	
		254	22,1	50,8	1123	63,5	1403	78,7	1739	94,0	2077	110,3	
7,20 x 4,00		305	20,6	61,0	1257	76,3	1572	94,6	1949	112,9	2326	133,4	
38,5	19,5	51	178,5	10,2	1821	12,8	2285	15,8	2820	18,9	3374	21,5	
		64	132,4	12,8	1695	16,0	2118	19,8	2622	23,7	3138	26,3	
		76	107,9	15,2	1640	19,0	2050	23,6	2546	28,1	3032	33,2	
		89	94,1	17,8	1675	22,3	2098	27,6	2597	32,9	3096	40,0	
		102	82,4	20,4	1681	25,5	2101	31,6	2604	37,7	3106	44,7	
		115	73,7	23,0	1695	28,8	2123	35,7	2631	42,6	3140	50,1	
		127	62,8	25,4	1595	31,8	1997	39,4	2474	47,0	2952	55,2	
		140	58,8	28,0	1646	35,0	2058	43,4	2552	51,8	3046	61,3	
		152	52,0	30,4	1581	38,0	1976	47,1	2449	56,2	2922	67,6	
		178	44,1	35,6	1570	44,5	1962	55,2	2434	65,9	2906	79,2	
		203	37,3	40,6	1514	50,8	1895	62,9	2346	75,1	2801	89,7	
8,00 x 5,10		305	24,5	61,0	1495	76,3	1869	94,6	2318	112,9	2766	138,7	
51	25,5	64	210,8	12,8	2698	16,0	3373	19,8	4174	23,7	4996	27,3	
		76	171,6	15,2	2608	19,0	3260	23,6	4050	28,1	4822	31,1	
		89	142,2	17,8	2531	22,3	3171	27,6	3925	32,9	4678	38,2	
		102	119,6	20,4	2440	25,5	3050	31,6	3779	37,7	4509	43,5	
		115	107,9	23,0	2482	28,8	3108	35,7	3852	42,6	4597	48,3	
		127	100,0	25,4	2540	31,8	3180	39,4	3940	47,0	4700	55,1	
		140	90,2	28,0	2526	35,0	3157	43,4	3915	51,8	4672	61,4	
		152	84,3	30,4	2563	38,0	3203	47,1	3971	56,2	4738	67,5	
		178	71,1	35,6	2531	44,5	3164	55,2	3925	65,9	4685	79,1	
		203	61,8	40,6	2509	50,8	3139	62,9	3887	75,1	4641	89,2	
11,40 x 5,80		305	43,1	61,0	2629	76,3	3289	94,6	4077	112,9	4866	143,4	
63	38	76	300,1	15,2	4562	19,0	5702	23,6	7082	28,1	8433	29,3	
		89	240,3	17,8	4277	22,3	5359	27,6	6632	32,9	7906	36,1	
		102	211,8	20,4	4321	25,5	5401	31,6	6693	37,7	7985	43,9	
		115	188,3	23,0	4331	28,8	5423	35,7	6722	42,6	8022	48,4	
		127	162,8	25,4	4135	31,8	5177	39,4	6414	47,0	7652	55,2	
		140	156,9	28,0	4393	35,0	5492	43,4	6809	51,8	8127	63,9	
		152	147,1	30,4	4472	38,0	5590	47,1	6928	56,2	8267	66,0	
		178	108,9	35,6	3877	44,5	4846	55,2	6011	65,9	7177	76,9	
		203	94,1	40,6	3820	50,8	4780	62,9	5919	75,1	7067	86,7	
		229	86,3	45,8	3953	57,3	4945	71,0	6127	84,7	7310	99,0	
		254	75,5	50,8	3835	63,5	4794	78,7	5942	94,0	7097	112,2	
11,50 x 9,70		305	64,7	61,0	3947	76,3	4937	94,6	6121	112,9	7305	132,9	

Forma de pedido: ROR + D1 * L
How to order: ROR + D1 * L

MUELLE OVALADO CARGA FUERTE ROG

HEAVY LOAD OVAL SPRINGS ROG

STOCK

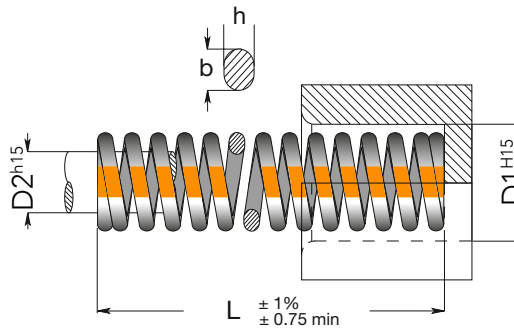

ROG

Norma / Standard: US standard











D1	D2	L	R	A		B		C		D		E
Diámetro del alojamiento Hole diameter	Diámetro de la guía Spring inside diameter	Longitud libre Free length	Constante elástica ±10 Spring constant ±10		15% L		20% L		25% L		30% L	
b x h			±10%	+ 3.000.000		~ 1.500.000		300 - 500.00		100 - 200.00		
mm	mm	mm	N/mm	mm	N	mm	N	mm	N	mm	N	mm
9,5	4,7	25	22,5	3,8	85,5	5,0	112,5	6,3	141,8	7,5	168,8	9,2
		32	18,6	4,8	89,3	6,4	119,0	8,0	148,8	9,6	178,6	12,1
		38	15,9	5,7	90,6	7,6	120,8	9,5	151,1	11,4	181,3	13,2
		44	13,7	6,6	90,4	8,8	120,6	11,0	150,7	13,2	180,8	15,1
		51	11,8	7,7	90,9	10,2	120,4	12,8	151,0	15,3	180,5	19,5
		64	8,8	9,6	84,5	12,8	112,6	16,0	140,8	19,2	169,0	21,8
		76	6,4	11,4	73,0	15,2	97,3	19,0	121,6	22,8	145,9	27,9
1,90 x 1,50		305	1,7	45,8	77,9	61,0	103,7	76,3	129,7	91,5	155,6	127,2
13	7	25	37,3	3,8	141,7	5,0	186,5	6,3	235,0	7,5	279,8	9,8
		32	32,5	4,8	156,0	6,4	208,0	8,0	260,0	9,6	312,0	12,6
		38	28,4	5,7	161,9	7,6	215,8	9,5	269,8	11,4	323,8	14,6
		44	24,5	6,6	161,7	8,8	215,6	11,0	269,5	13,2	323,4	18,1
		51	18,6	7,7	143,2	10,2	189,7	12,8	238,1	15,3	284,6	22,3
		64	15,7	9,6	150,7	12,8	201,0	16,0	251,2	19,2	301,4	27,3
		76	13,7	11,4	156,2	15,2	208,2	19,0	260,3	22,8	312,4	33,1
		89	10,8	13,4	144,7	17,8	192,2	22,3	240,8	26,7	288,4	38,9
102	7,4	15,3	113,2	20,4	151,0	25,5	188,7	30,6	226,4	43,8		
2,40 x 1,90		305	3,1	45,8	142,0	61,0	189,1	76,3	236,5	91,5	283,7	139,7
16	8,7	25	78,2	3,8	297,2	5,0	391,0	6,3	492,7	7,5	586,5	8,4
		32	59,8	4,8	287,0	6,4	382,7	8,0	478,4	9,6	574,1	10,5
		38	51,0	5,7	290,7	7,6	387,6	9,5	484,5	11,4	581,4	13,6
		44	43,1	6,6	284,5	8,8	379,3	11,0	474,1	13,2	568,9	15,9
		51	38,2	7,7	294,1	10,2	389,6	12,8	489,0	15,3	584,5	18,9
		64	31,4	9,6	301,4	12,8	401,9	16,0	502,4	19,2	602,9	24,9
		76	24,5	11,4	279,3	15,2	372,4	19,0	465,5	22,8	558,6	29,2
		89	20,6	13,4	276,0	17,8	366,7	22,3	459,4	26,7	550,0	34,5
		102	18,6	15,3	284,6	20,4	379,4	25,5	474,3	30,6	569,2	39,1
		115	15,7	17,3	271,6	23,0	361,1	28,8	452,2	34,5	541,7	44,0
3,10 x 2,50		305	5,7	45,8	261,1	61,0	347,7	76,3	434,9	91,5	521,6	103,6

Continúa en la siguiente página...
Continue next page...

Forma de pedido: ROG + D1 * L
How to order: ROG + D1 * L









ROG

D1	D2	L	R		A		B		C		D		E
Diámetro del alojamiento Hole diameter	Diámetro de la guía Spring inside diameter	Longitud libre Free length	Constante elástica ±10 Spring constant ±10		15% L		20% L		25% L		30% L		 aprox. no usar aprox. do not use
b x h			±10%	+ 3.000.000		~ 1.500.000		300 - 500.00		100 - 200.00			
mm	mm	mm	N/mm	mm	N	mm	N	mm	N	mm	N	mm	mm
19,5	9,5	25	181,4	3,8	689	5,0	907	6,3	1143	7,5	1361	8,5	
		32	137,3	4,8	659	6,4	879	8,0	1098	9,6	1318	11,0	
		38	107,9	5,7	615	7,6	820	9,5	1025	11,4	1230	12,7	
		44	94,1	6,6	621	8,8	828	11,0	1035	13,2	1242	15,2	
		51	78,5	7,7	604	10,2	801	12,8	1005	15,3	1201	17,8	
		64	65,0	9,6	624	12,8	832	16,0	1040	19,2	1248	22,9	
		76	56,9	11,4	649	15,2	865	19,0	1081	22,8	1297	27,8	
		89	47,1	13,4	631	17,8	838	22,3	1050	26,7	1258	32,1	
		102	41,2	15,3	630	20,4	840	25,5	1051	30,6	1261	37,1	
		115	36,3	17,3	628	23,0	835	28,8	1045	34,5	1252	43,0	
		127	32,4	19,1	619	25,4	823	31,8	1030	38,1	1234	46,8	
		140	29,4	21,0	617	28,0	823	35,0	1029	42,0	1235	53,1	
152	25,5	22,8	581	30,4	775	38,0	969	45,6	1163	56,4			
4,00 x 3,20		305	14,7	45,8	673	61,0	897	76,3	1122	91,5	1345	115,3	
25,5	13	25	333,4	3,8	1267	5,0	1667	6,3	2100	7,5	2501	7,7	
		32	257,4	4,8	1236	6,4	1647	8,0	2059	9,6	2471	10,6	
		38	210,8	5,7	1202	7,6	1602	9,5	2003	11,4	2403	12,8	
		44	176,5	6,6	1165	8,8	1553	11,0	1942	13,2	2330	15,2	
		51	148,1	7,7	1140	10,2	1511	12,8	1896	15,3	2266	17,7	
		64	119,6	9,6	1148	12,8	1531	16,0	1914	19,2	2296	22,9	
		76	100,0	11,4	1140	15,2	1520	19,0	1900	22,8	2280	27,5	
		89	83,4	13,4	1118	17,8	1485	22,3	1860	26,7	2227	32,6	
		102	73,6	15,3	1126	20,4	1501	25,5	1877	30,6	2252	39,7	
		115	63,7	17,3	1102	23,0	1465	28,8	1835	34,5	2198	42,7	
		127	56,9	19,1	1087	25,4	1445	31,8	1809	38,1	2168	47,9	
		140	51,0	21,0	1071	28,0	1428	35,0	1785	42,0	2142	52,9	
		152	47,1	22,8	1074	30,4	1432	38,0	1790	45,6	2148	57,0	
		178	41,2	26,7	1100	35,6	1467	44,5	1833	53,4	2200	68,2	
203	36,3	30,5	1107	40,6	1474	50,8	1844	60,9	2211	77,4			
5,50 x 4,10		305	22,6	45,8	1035	61,0	1379	76,3	1724	91,5	2068	113,0	
32	16	38	362,9	5,7	2069	7,6	2758	9,5	3448	11,4	4137	12,6	
		44	307,9	6,6	2032	8,8	2710	11,0	3387	13,2	4064	13,7	
		51	262,8	7,7	2024	10,2	2681	12,8	3364	15,3	4021	16,0	
		64	205,9	9,6	1977	12,8	2636	16,0	3294	19,2	3953	21,8	
		76	171,6	11,4	1956	15,2	2608	19,0	3260	22,8	3912	26,7	
		89	147,1	13,4	1971	17,8	2618	22,3	3280	26,7	3928	29,9	
102	127,5	15,3	1951	20,4	2601	25,5	3251	30,6	3902	37,1			

Continúa en la siguiente página...
Continue next page...

Forma de pedido: ROG + D1 * L
How to order: ROG + D1 * L

ROG

D1	D2	L	R		A		B		C		D		E
Diámetro del alojamiento Hole diameter	Diámetro de la guía Spring inside diameter	Longitud libre Free length	Constante elástica ±10 Spring constant ±10		15% L		20% L		25% L		30% L		 aprox. no usar approx. do not use
b x h			±10%		+ 3.000.000		~ 1.500.000		300 - 500.00		100 - 200.00		
mm	mm	mm	N/mm	mm	N	mm	N	mm	N	mm	N	mm	mm
32	16	115	112,8	17,3	1951	23,0	2594	28,8	3249	34,5	3892	41,6	
		127	101,0	19,1	1929	25,4	2565	31,8	3212	38,1	3848	45,1	
		140	88,3	21,0	1854	28,0	2472	35,0	3091	42,0	3709	51,0	
		152	80,9	22,8	1845	30,4	2459	38,0	3074	45,6	3689	54,6	
		178	68,6	26,7	1832	35,6	2442	44,5	3053	53,4	3663	65,0	
		203	59,8	30,5	1824	40,6	2428	50,8	3038	60,9	3642	75,7	
		254	46,9	38,1	1787	50,8	2383	63,5	2978	76,2	3574	95,6	
7,40 x 5,20		305	39,2	45,8	1795	61,0	2391	76,3	2991	91,5	3587	118,0	
38,5	19,5	51	313,8	7,7	2416	10,2	3201	12,8	4017	15,3	4801	21,4	
		64	230,5	9,6	2213	12,8	2950	16,0	3688	19,2	4426	28,8	
		76	196,1	11,4	2236	15,2	2981	19,0	3726	22,8	4471	33,6	
		89	171,6	13,4	2299	17,8	3054	22,3	3827	26,7	4582	40,3	
		102	142,2	15,3	2176	20,4	2901	25,5	3626	30,6	4351	46,1	
		115	124,5	17,3	2154	23,0	2864	28,8	3586	34,5	4295	52,2	
		127	112,8	19,1	2154	25,4	2865	31,8	3587	38,1	4298	58,4	
		140	103,0	21,0	2163	28,0	2884	35,0	3605	42,0	4326	64,5	
		152	93,2	22,8	2125	30,4	2833	38,0	3542	45,6	4250	70,8	
		178	80,4	26,7	2147	35,6	2862	44,5	3578	53,4	4293	82,0	
		203	70,6	30,5	2153	40,6	2866	50,8	3586	60,9	4300	95,8	
		254	56,9	38,1	2168	50,8	2891	63,5	3613	76,2	4336	118,6	
8,50 x 5,70		305	47,1	45,8	2157	61,0	2873	76,3	3594	91,5	4310	145,5	
51	25,5	64	392,3	9,6	3766	12,8	5021	16,0	6277	19,2	7532	22,5	
		76	328,5	11,4	3745	15,2	4993	19,0	6242	22,8	7490	27,2	
		89	274,6	13,4	3680	17,8	4888	22,3	6124	26,7	7332	32,0	
		102	235,4	15,3	3602	20,4	4802	25,5	6003	30,6	7203	36,9	
		115	205,9	17,3	3562	23,0	4736	28,8	5930	34,5	7104	42,8	
		127	186,3	19,1	3558	25,4	4732	31,8	5924	38,1	7098	47,5	
		140	166,7	21,0	3501	28,0	4668	35,0	5835	42,0	7001	54,2	
		152	147,1	22,8	3354	30,4	4472	38,0	5590	45,6	6708	58,1	
		178	127,5	26,7	3404	35,6	4539	44,5	5674	53,4	6809	69,6	
		203	112,8	30,5	3440	40,6	4580	50,8	5730	60,9	6870	80,3	
		254	88,3	38,1	3364	50,8	4486	63,5	5607	76,2	6728	101,7	
11,66 x 7,20		305	70,6	45,8	3233	61,0	4307	76,3	5387	91,5	6460	123,9	

Forma de pedido: ROG + D1 * L
How to order: ROG + D1 * L

MUELLE OVALADO CARGA EXTRA-FUERTE ROV
EXTRA-HEAVY LOAD OVAL SPRINGS ROV

STOCK

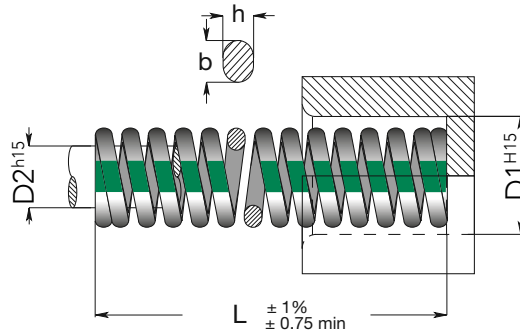

ROV

Norma / Standard: US standard





D1	D2	L	R	A	B	C	D	E				
Diámetro del alojamiento Hole diameter	Diámetro de la guía Spring inside diameter	Longitud libre Free length	Constante elástica ±10 Spring constant ± 10	15% L	20% L	22.5% L	25% L	aprox. no usar aprox. do not use				
b x h		±10%	+ 3.000.000	~ 1.500.000	300 - 500.00	100 - 200.00						
mm	mm	mm	N/mm	mm N	mm N	mm N	mm N	mm				
9,5	4,7	25	38,5	3,8	146,3	5,0	192,5	5,6	215,6	6,3	242,6	7,9
		32	29,7	4,8	142,6	6,4	190,1	7,2	213,8	8,0	237,6	10,9
		38	25,4	5,7	144,8	7,6	193,0	8,6	218,4	9,5	241,3	13,4
		44	20,2	6,6	133,3	8,8	177,8	9,9	200,0	11,0	222,2	13,8
		51	17,6	7,7	135,5	10,2	179,5	11,5	202,4	12,8	225,3	16,8
		64	14,0	9,6	134,4	12,8	179,2	14,4	201,6	16,0	224,0	20,2
		76	11,4	11,4	130,0	15,2	173,3	17,1	194,9	19,0	216,6	25,9
1,97 x 1,50		305	2,6	45,8	119,1	61,0	158,6	68,6	178,4	76,3	198,4	113,5
13	7	25	56,1	3,8	213,2	5,0	280,5	5,6	314,2	6,3	353,4	8,5
		32	42,1	4,8	202,1	6,4	269,4	7,2	303,1	8,0	336,8	10,5
		38	35,0	5,7	199,5	7,6	266,0	8,6	301,0	9,5	332,5	12,8
		44	29,8	6,6	196,7	8,8	262,2	9,9	295,0	11,0	327,8	14,0
		51	24,5	7,7	188,7	10,2	249,9	11,5	281,8	12,8	313,6	16,1
		64	20,2	9,6	193,9	12,8	258,6	14,4	290,9	16,0	323,2	21,1
		76	15,8	11,4	180,1	15,2	240,2	17,1	270,2	19,0	300,2	24,5
		89	14,0	13,4	187,6	17,8	249,2	20,0	280,0	22,3	312,2	30,0
102	10,8	15,3	165,2	20,4	220,3	23,0	248,4	25,5	275,4	35,6		
2,50 x 2,00		305	4,4	45,8	201,5	61,0	268,4	68,6	301,8	76,3	335,7	104,7
16	8,7	25	110,3	3,8	419,1	5,0	551,5	5,6	617,7	6,3	694,9	7,8
		32	82,3	4,8	395,0	6,4	526,7	7,2	592,6	8,0	658,4	10,2
		38	66,7	5,7	380,2	7,6	506,9	8,6	573,6	9,5	633,7	12,2
		44	56,1	6,6	370,3	8,8	493,7	9,9	555,4	11,0	617,1	14,0
		51	50,8	7,7	391,2	10,2	518,2	11,5	584,2	12,8	650,2	16,6
		64	38,5	9,6	369,6	12,8	492,8	14,4	554,4	16,0	616,0	19,5
		76	31,5	11,4	359,1	15,2	478,8	17,1	538,7	19,0	598,5	25,8
		89	28,0	13,4	375,2	17,8	498,4	20,0	560,0	22,3	624,4	29,5
		102	23,6	15,3	361,1	20,4	481,4	23,0	542,8	25,5	601,8	33,9
		115	20,6	17,3	356,4	23,0	473,8	25,9	533,5	28,8	593,3	38,3
3,10 x 2,76		305	7,8	45,8	357,2	61,0	475,8	68,6	535,1	76,3	595,1	89,9

Continúa en la siguiente página...
 Continue next page...

Forma de pedido: ROV + D1 * L
 How to order: ROV + D1 * L









ROV

D1	D2	L	R	A		B		C		D		E
Diámetro del alojamiento Hole diameter	Diámetro de la guía Spring inside diameter	Longitud libre Free length	Constante elástica ±10 Spring constant ±10		15% L		20% L		22.5% L		25% L	 <small>aprox. no usar aprox. do not use</small>
b x h			±10%	+ 3.000.000		~ 1.500.000		300 - 500.00		100 - 200.00		
mm	mm	mm	N/mm	mm	N	mm	N	mm	N	mm	N	mm
19,5	9,5	25	205,9	3,8	782	5,0	1030	5,6	1153	6,3	1297	7,1
		32	166,7	4,8	800	6,4	1067	7,2	1200	8,0	1334	9,4
		38	132,4	5,7	755	7,6	1006	8,6	1139	9,5	1258	11,6
		44	117,7	6,6	777	8,8	1036	9,9	1165	11,0	1295	13,9
		51	98,1	7,7	755	10,2	1001	11,5	1128	12,8	1256	16,2
		64	83,4	9,6	801	12,8	1068	14,4	1201	16,0	1334	21,5
		76	68,6	11,4	782	15,2	1043	17,1	1173	19,0	1303	25,0
		89	54,9	13,4	736	17,8	977	20,0	1098	22,3	1224	30,4
		102	48,1	15,3	736	20,4	981	23,0	1106	25,5	1227	34,9
		115	41,2	17,3	713	23,0	948	25,9	1067	28,8	1187	42,0
		127	38,2	19,1	730	25,4	970	28,6	1093	31,8	1215	46,4
		140	33,3	21,0	699	28,0	932	31,5	1049	35,0	1166	49,1
152	31,4	22,8	716	30,4	955	34,2	1074	38,0	1193	53,5		
4,00 x 3,60		305	16,5	45,8	756	61,0	1007	68,6	1132	76,3	1259	115,0
25,5	13	25	441,3	3,8	1677	5,0	2207	5,6	2471	6,3	2780	6,7
		32	343,2	4,8	1647	6,4	2196	7,2	2471	8,0	2746	9,5
		38	323,6	5,7	1845	7,6	2459	8,6	2783	9,5	3074	11,8
		44	264,8	6,6	1748	8,8	2330	9,9	2622	11,0	2913	14,1
		51	201,0	7,7	1548	10,2	2050	11,5	2312	12,8	2573	17,0
		64	156,9	9,6	1506	12,8	2008	14,4	2259	16,0	2510	21,0
		76	127,5	11,4	1454	15,2	1938	17,1	2180	19,0	2423	24,9
		89	107,9	13,4	1446	17,8	1921	20,0	2158	22,3	2406	29,9
		102	96,1	15,3	1470	20,4	1960	23,0	2210	25,5	2451	33,9
		115	84,3	17,3	1458	23,0	1939	25,9	2183	28,8	2428	39,1
		127	75,5	19,1	1442	25,4	1918	28,6	2159	31,8	2401	42,2
		140	63,7	21,0	1338	28,0	1784	31,5	2007	35,0	2230	47,7
152	62,8	22,8	1432	30,4	1909	34,2	2148	38,0	2386	51,1		
178	53,9	26,7	1439	35,6	1919	40,1	2161	44,5	2399	62,1		
203	46,1	30,5	1406	40,6	1872	45,7	2107	50,8	2342	70,0		
5,50 x 4,70		305	33,3	45,8	1525	61,0	2031	68,6	2284	76,3	2541	105,5
32	16	38	470,7	5,7	2683	7,6	3577	8,6	4048	9,5	4472	10,2
		44	392,3	6,6	2589	8,8	3452	9,9	3884	11,0	4315	13,0
		51	333,4	7,7	2567	10,2	3401	11,5	3834	12,8	4268	15,3
		64	264,8	9,6	2542	12,8	3389	14,4	3813	16,0	4237	20,4
		76	215,7	11,4	2459	15,2	3279	17,1	3688	19,0	4098	23,2
		89	166,7	13,4	2234	17,8	2967	20,0	3334	22,3	3717	28,3
102	147,1	15,3	2251	20,4	3001	23,0	3383	25,5	3751	33,4		

Continúa en la siguiente página...
Continue next page...

Forma de pedido: ROV + D1 * L
How to order: ROV + D1 * L

ROV

D1	D2	L	R		A		B		C		D		E
Diámetro del alojamiento Hole diameter	Diámetro de la guía Spring inside diameter	Longitud libre Free length	Constante elástica ±10 Spring constant ±10		15% L		20% L		22.5% L		25% L		 aprox. no usar aprox. do not use
b x h			±10%	+ 3.000.000		~ 1.500.000		300 - 500.00		100 - 200.00			
mm	mm	mm	N/mm	mm	N	mm	N	mm	N	mm	N	mm	mm
32	16	115	137,3	17,3	2375	23,0	3158	25,9	3556	28,8	3954	38,6	
		127	127,5	19,1	2435	25,4	3239	28,6	3647	31,8	4055	41,3	
		140	112,8	21,0	2369	28,0	3158	31,5	3553	35,0	3948	45,0	
		152	103,0	22,8	2348	30,4	3131	34,2	3523	38,0	3914	49,9	
		178	92,2	26,7	2462	35,6	3282	40,1	3697	44,5	4103	58,1	
		203	75,5	30,5	2303	40,6	3065	45,7	3450	50,8	3835	66,0	
		254	60,8	38,1	2316	50,8	3089	57,2	3478	63,5	3861	82,7	
7,40 x 6,00		305	49,0	45,8	2244	61,0	2989	68,6	3361	76,3	3739	99,5	
38,5	19,5	51	539,4	7,7	4153	10,2	5502	11,5	6203	12,8	6904	13,8	
		64	460,9	9,6	4425	12,8	5900	14,4	6637	16,0	7374	19,9	
		76	353,0	11,4	4024	15,2	5366	17,1	6036	19,0	6707	22,9	
		89	264,2	13,4	3540	17,8	4703	20,0	5284	22,3	5892	28,9	
		102	255,0	15,3	3902	20,4	5202	23,0	5865	25,5	6503	31,9	
		115	225,6	17,3	3903	23,0	5189	25,9	5843	28,8	6497	36,2	
		127	201,0	19,1	3839	25,4	5105	28,6	5749	31,8	6392	41,0	
		140	186,3	21,0	3912	28,0	5216	31,5	5868	35,0	6521	45,3	
		152	166,7	22,8	3801	30,4	5068	34,2	5701	38,0	6335	50,2	
		178	147,1	26,7	3928	35,6	5237	40,1	5899	44,5	6546	57,7	
		203	127,5	30,5	3889	40,6	5177	45,7	5827	50,8	6477	68,7	
254	98,1	38,1	3738	50,8	4983	57,2	5611	63,5	6229	84,3			
8,50 x 7,50		305	83,4	45,8	3820	61,0	5087	68,6	5721	76,3	6363	105,3	
51	25,5	64	645,3	9,6	6195	12,8	8260	14,4	9292	16,0	10325	16,5	
		76	554,1	11,4	6317	15,2	8422	17,1	9475	19,0	10528	20,9	
		89	451,1	13,4	6045	17,8	8030	20,0	9022	22,3	10060	23,9	
		102	402,1	15,3	6152	20,4	8203	23,0	9248	25,5	10254	29,3	
		115	343,2	17,3	5937	23,0	7894	25,9	8889	28,8	9884	32,3	
		127	313,8	19,1	5994	25,4	7971	28,6	8975	31,8	9979	36,7	
		140	284,4	21,0	5972	28,0	7963	31,5	8959	35,0	9954	40,7	
		152	264,8	22,8	6037	30,4	8050	34,2	9056	38,0	10062	44,1	
		178	225,6	26,7	6024	35,6	8031	40,1	9047	44,5	10039	51,6	
		203	193,7	30,5	5908	40,6	7864	45,7	8852	50,8	9840	57,6	
254	153,0	38,1	5829	50,8	7772	57,2	8752	63,5	9716	73,3			
11,40 x 9,30		350	146,1	45,8	6691	61,0	8912	68,6	10022	76,3	11147	89,2	

Forma de pedido: ROV + D1 * L
How to order: ROV + D1 * L

ELASTÓMERO BARRA MACIZA ELAM SOLID BAR ELASTOMER ELAM

Material: Poliuretano / Polyurethane

Dureza / Hardness:

70 Shore A

80 Shore A

90 Shore A

95 Shore A

STOCK

D	L		D	L
	100	250		
6	•	-	70	•
8	•	-	75	•
10	-	•	80	•
12	-	•	85	•
13	-	•	90	•
15	-	•	95	•
16	-	•	100	•
18	-	•	105	•
20	-	•	110	•
24	-	•	115	•
25	-	•	120	•
30	-	•	125	•
32	-	•	130	•
35	-	•	140	•
40	-	•	150	•
45	-	•	160	•
50	-	•	170	•
55	-	•	180	•
60	-	•	190	•
63	-	•	200	•

Forma de pedido: ELAM + D * L + Dureza

How to order: ELAM + D * L + Hardness

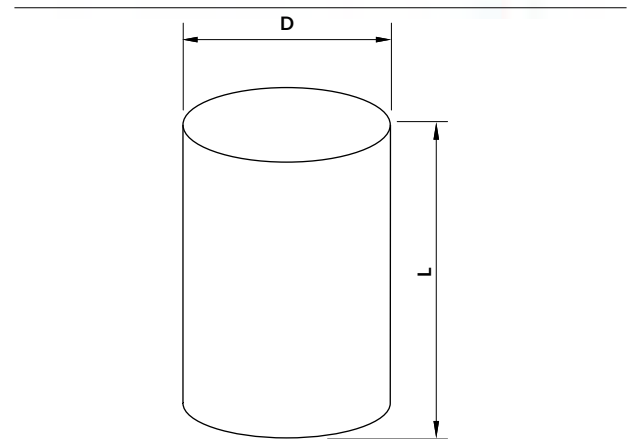

ELASTÓMERO BARRA HUECA ELAH HOLLOW BAR ELASTOMER ELAH

Material: Poliuretano / Polyurethane

Dureza / Hardness:

70 Shore A

80 Shore A

90 Shore A

95 Shore A

STOCK

D	d	L
		250
20	8,5	•
25	10,5	•
32	13,5	•
40	13,5	•
45	15	•
50	17	•
55	17	•
63	17	•
70	17	•
80	21	•
90	21	•
100	21	•
110	21	•
120	21	•
125	27	•
150	27	•
175	27	•
200	27	•

Forma de pedido: ELAH + D * L + Dureza

How to order: ELAH + D * L + Hardness

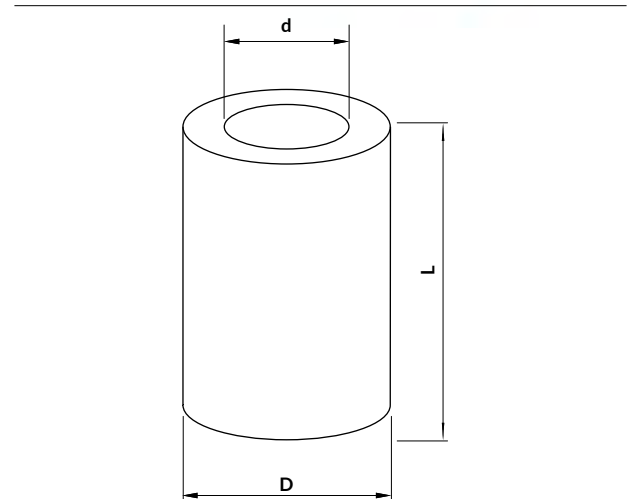

DESPEGADORES DE ELASTÓMERO DESR STRIPPER BAR DESR

Material: NBR

Dureza / Hardness: 70 Shore A

STOCK

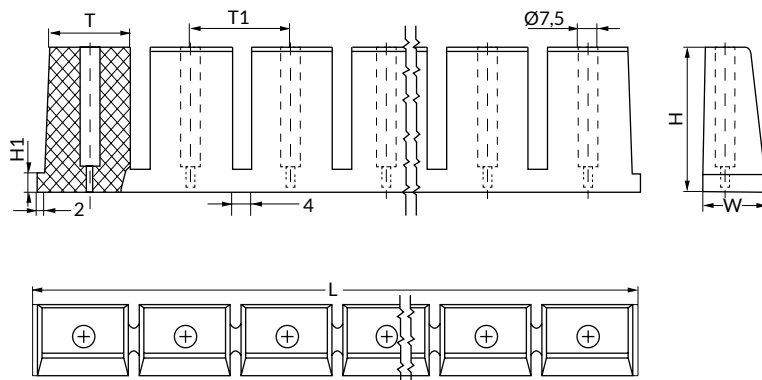

Forma A / Form A

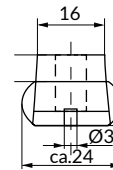

Forma B / Form B

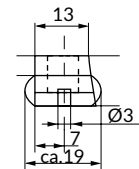

Forma C / Form C

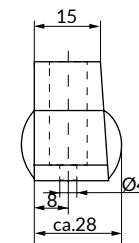

W	H	L	T	H1	T1	Forma / Form	Nº de segmento / Nº of segments
19	16,6	270	26	3	30	A	9
15	11,5	270	26	4	34	B	9
19	27	306	30	3	30	C	9

Forma de pedido: DESR + W*L

How to order: DESR + W*L

DESPEGADORES DE ELASTÓMERO DESC

STRIPPER BAR DESC

STOCK



Forma A/ Form A

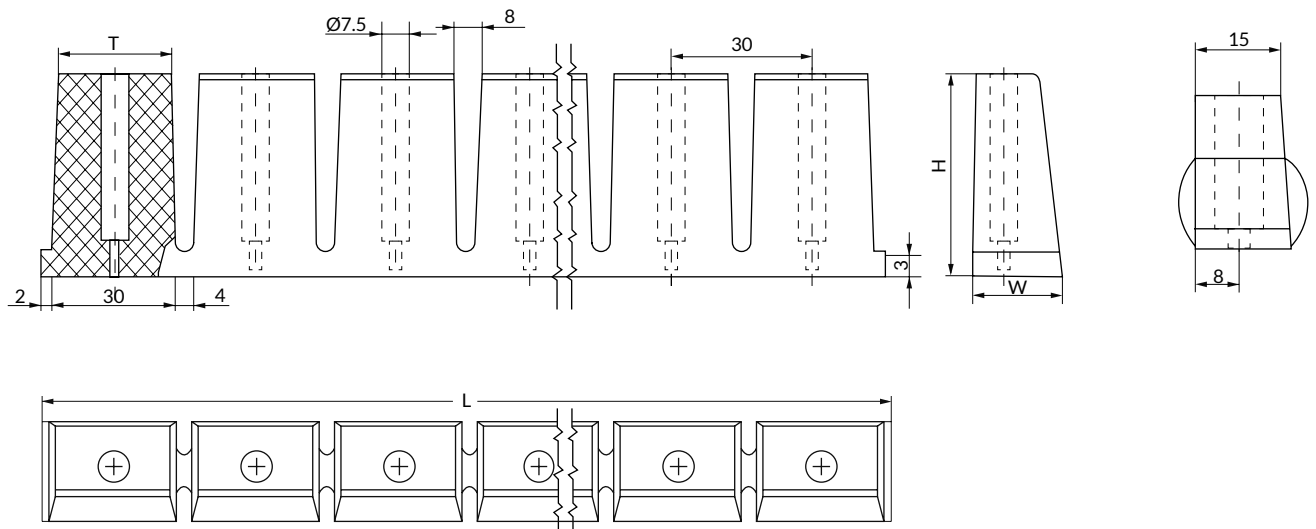

Forma B/ Form B

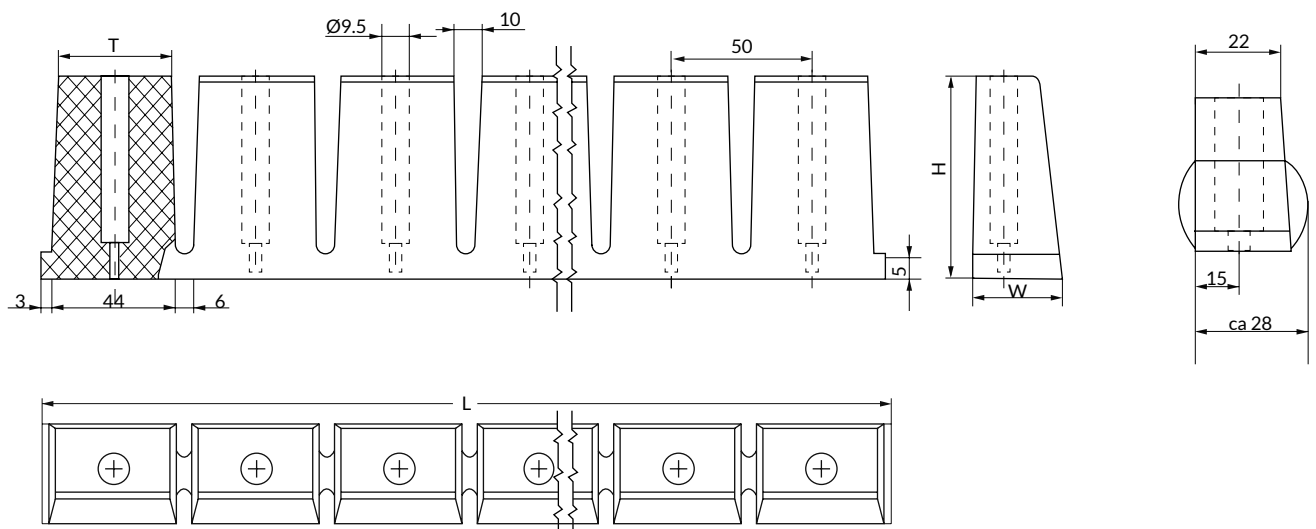

W	H	L	T	Material	Dureza / Hardness	Forma / Form	Nº de segmento / Nº of segments
19	27	306	26	NBR	70 Shore A	A	9
32	65	400	40	Poliuretano / Polyurethane	90 Shore A	B	8

Forma de pedido: DESC + W*L
How to order: DESC + W*L

DESPEGADOR DEST STRIPPER DEST

Material: Poliuretano / Polyurethane
Dureza / Hardness: 90 Shore A

STOCK

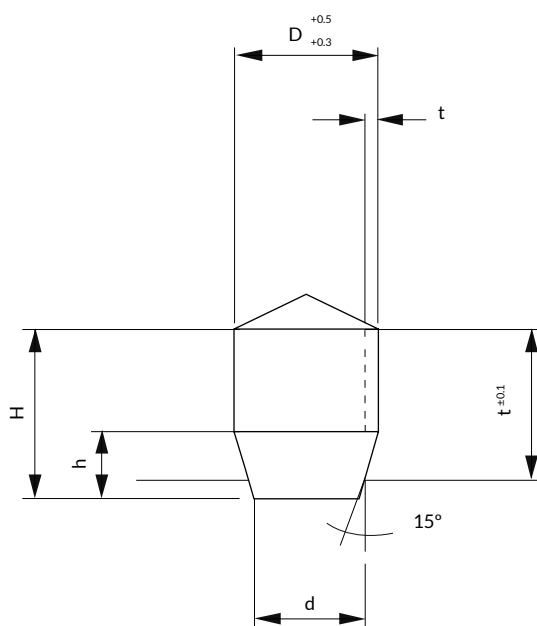

Norma / Standard: DIN 9835

D	H	h	d	t	F (N) max.
6	9,5	4,5	3,6	8	100
10	15,5	7,5	6	13	450
16	25	12	9,5	21	1500
24	25	10	18	21	3000
30	35	19	20	30	3000
32	32	14	24	26	12000
39,5	40	16	30	34	25000

Forma de pedido: DEST + D
How to order: DEST + D

GUÍA PARA ELASTÓMERO ELAG

GUIDE BOLT FOR ELASTOMER ELAG

Material: CK45

STOCK

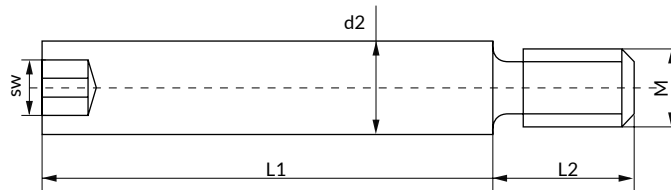

Norma / Standard: DIN ISO 10069-2, Form B

M	d2	sw	L2	L1 ^{+0.05}												
				15	20	25	32	40	50	63	80	95	118	140	180	200
M5	6	3	6	•	•	•	•	•	•	-	-	-	-	-	-	-
M6	8	4	9	•	•	•	•	•	•	•	•	-	-	-	-	-
M8	10	5	15	•	•	•	•	•	•	•	•	•	-	-	-	-
M10	13	6	15	•	•	•	•	•	•	•	•	•	•	-	-	-
M12	16	8	18	-	•	•	•	•	•	•	•	•	•	•	•	-
M16	20	10	25	-	-	•	•	•	•	•	•	•	•	•	•	•
M20	25	14	30	-	-	-	•	•	•	•	•	•	•	•	•	•

Forma de pedido: ELAG + M + L1

How to order: ELAG + M + L1

POSICIONADOR DE BOLA PB BALL PLUNGER PB

Material cuerpo: Acero de decoletaje, pavonado
Body material: Blued steel for casting

Material bola: Acero para rodamientos, templado
Ball material: Hardened steel for bearings

STOCK

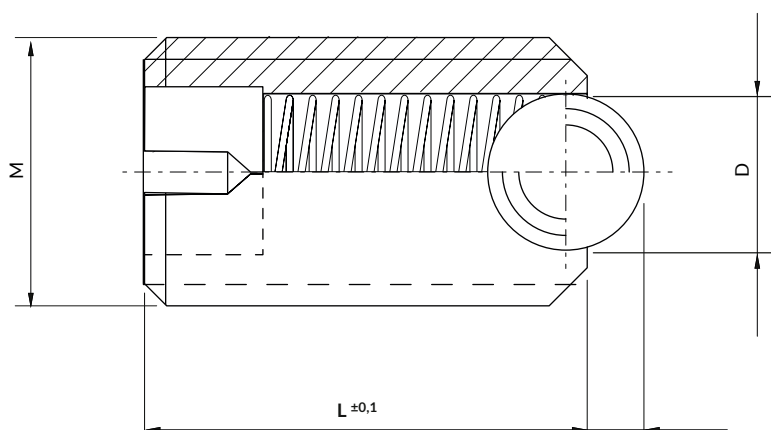

M	D	L	W	Presión del muelle daN / Spring Pressure	
				Min.	Max
M3	1,5	7	0,4	0,3	0,45
M4	2,5	9	0,8	0,85	1,45
M5	3	12	0,9	0,8	1,4
M6	3,5	14	1	1,1	1,8
M8	4,5	16	1,5	1,8	3,1
M10	6	19	2	2,4	4,5
M12	8	22	2,5	2,6	4,9
M16	10	24	3,5	4,1	8,6
M20	12	30	4,5	5,6	11,1
M24	15	34	5,5	8,1	15,1

Forma de pedido: PB + m
How to order: PB + m

EXPULSOR DE MUELLE EMA SPRING PLUNGER EMA

Material cuerpo: Acero de decoletaje, pavonado
Body material: Blued steel for casting

Material vástago: Acero de decoletaje, templado
Rod material: Tempered steel for casting

STOCK

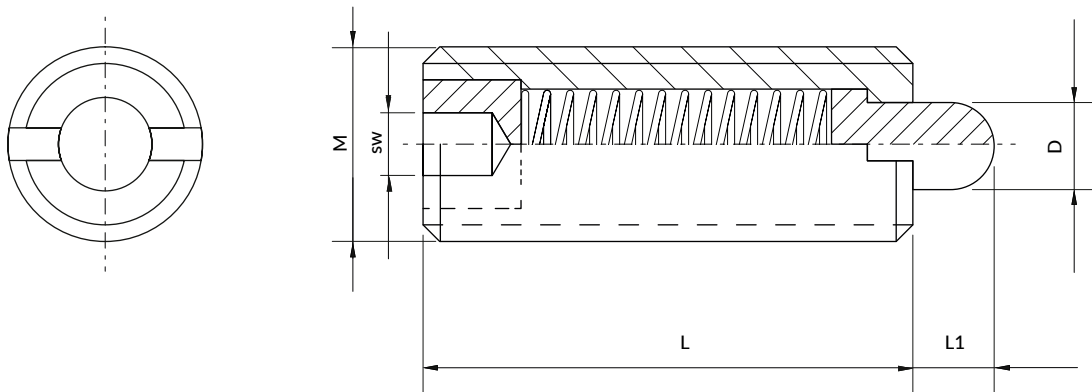

M	L	L1	D	sw	Presión del muelle daN / Spring Pressure daN		Carga / Duty
					Min.	Max.	
M3	10	1,5	1	0,8	0,05	0,3	
M4	12	2	1,6	0,8	0,2	1	
M5	20	3	2	1,5	0,4	2	
M6	25	3	2,5	2	0,8	3	FUERTE / HEAVY (H)
M8	25	3	3,1	2,5	0,8	3	
M10	30	5	3,8	3	1	5	
M12	30	5	5,5	4	1	5	
M5	20	3	2	1,5	0,2	1	
M6	25	3	2,5	2	0,3	1	LIGERA / LIGHT (L)
M8	25	3	3,1	2,5	0,3	1	
M10	30	5	3,8	3	0,3	1,5	
M12	30	5	5,5	4	0,2	1	

Forma de pedido: EMA + M + L1 + Carga
How to order: EMA + M + L1 + Duty

EXPULSOR DE MUELLE EMB SPRING PLUNGER EMB

Material cuerpo: Acero de decoletaje, pavonado
Body material: Blued steel for casting

Material vástago: Acero de decoletaje, templado
Rod material: Tempered steel for casting

STOCK

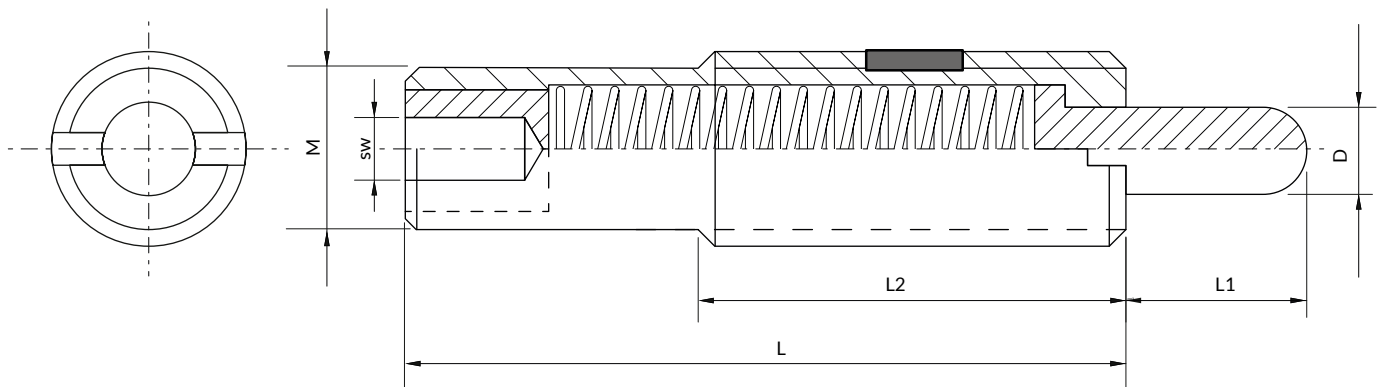



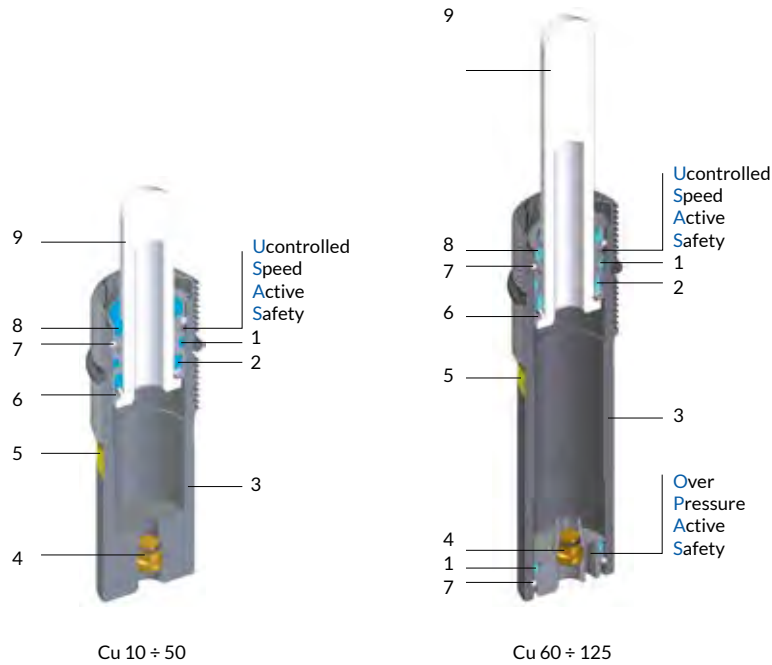

M	L	L1	L2	D	sw	Presión del muelle daN / Spring Pressure daN		Carga / Duty
						Min.	Max.	
M12	43	10	35	5,5	4	0,7	4	FUERTE /HEAVY (H)
M16	60	10	35	8	5	2,7	8	
M16	60	15	35	8	5	1,5	8	
M16	85	20	35	8	5	1,7	8	
M16	125	30	35	8	5	2	8	
M16	155	50	35	8	5	3	10	
M24	60	15	45	10	8	4	20	LIGERA /LIGHT (L)
M30	70	20	45	15	12	5	30	
M12	43	10	35	5,5	5	0,4	2	
M16	60	10	35	8	5	1,3	4	
M16	60	15	35	8	5	1	4	
M16	60	20	35	8	5	1,3	4	
M16	125	30	35	8	5	1,8	4	
M16	155	50	35	8	5	2	5	
M24	60	15	45	10	8	2	10	
M30	70	20	45	15	12	3	15	

Forma de pedido: EMB + M + L1 + Carga
How to order: EMB + M + L1+ Duty

EXPULSOR DE GAS NE-NG GAS EJECTOR NE-NG



Norma / Standard: VDI

Modelo Model	Cuerpo Ø Body Ø	Carrera Cu Stroke Cu	Fuerza inicial F0 Initial force F0				
	mm	mm	daN				
NE 16 x 1,5	M 16 x 1,5	10 - 125	3 - 42	-	•	-	-
NE 16 x 2	M 16 x 2	10 - 125	3 - 42	-	•	-	-
NG 16 x 1,5	M 16 x 1,5	10 - 100	3 - 42	-	•	-	-
NE 24 x 1,5	M 24 x 1,5	10 - 50	11 - 170	-	•	-	-
NE 24 x 1,5	M 24 x 1,5	60 - 125	11 - 170	-	•	•	-
NG 24 x 1,5	M 24 x 1,5	10 - 50	11 - 170	-	•	-	-
NG 24 x 1,5	M 24 x 1,5	60 - 100	11 - 170	-	•	•	-

1	Anillo dual / Dual ring seal	6	Casquillo / Bush
2	Retén / Rod seal	7	Anillo de retención / Retaining ring
3	Cuerpo / Body	8	Anillo antiextrusión / Rod wiper
4	Válvula / Valve	9	Vástago (nitruado) / Rod (nitrited super finished)
5	Código de color de fuerza / Force color code		

EXPULSOR DE GAS NE 16 x 1,5 GAS EJECTOR NE 16 x 1,5

Seguridad activa
Active safety



USAS

* F_{1i} =

Fuerza final isotérmica
a 100% Cu
Isothermal end force
at 100% Cu

** F_{1p} =

Fuerza final politrópica
a 100% Cu
Polytrophic end force
at 100% Cu

Recomendación de montaje
Assembly recommendation

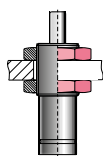

DM16

Ver / See p. 334

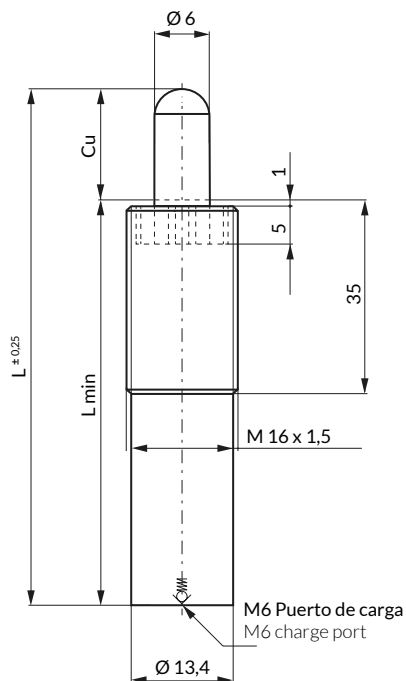

Norma / Standard: VDI 3400

		ΔP ± 0,33 % / °C	P max 150 bar	P min 10 bar	S 0,28 cm ²	SPM ~50 -100 (at 20°)	Velocidad Máx. Max Speed 1,8 m/s	Kit de mantenimiento Maintenance kit No disponible / Not available
--	--	-----------------------------	------------------	-----------------	---------------------------	--------------------------	--	--

Código Code	Cu	L	L min		PED 2014/68/EU
	mm	mm	mm		
NE 16 x 1,5-010	10	65	55	0,05	•
NE 16 x 1,5-020	20	85	65	0,06	•
NE 16 x 1,5-030	30	105	75	0,07	•
NE 16 x 1,5-040	40	125	85	0,07	•
NE 16 x 1,5-050	50	145	95	0,08	•
NE 16 x 1,5-060	60	165	105	0,08	•
NE 16 x 1,5-070	70	185	115	0,09	•
NE 16 x 1,5-080	80	205	125	0,10	•
NE 16 x 1,5-100	100	245	145	0,11	•
NE 16 x 1,5-125	125	295	170	0,12	•

P = Presión nominal de carga
P = Nominal charging pressure

Código color de fuerza Force color code	P	F ₀ Fuerza inicial Initial force	F _{1i} Fuerza final* End force*	F _{1p} Fuerza final** End force**
	bar	daN		
PR	12	4	1,56XF0	2,03XF0
GR	20	6	1,56XF0	2,03XF0
BU	40	11	1,56XF0	2,03XF0
RD	75	21	1,56XF0	2,03XF0
YW	150	42	1,56XF0	2,03XF0
BK	10-150	3-42	1,56XF0	2,03XF0

Forma de pedido: Código + Código de color de fuerza
How to order: Code + Force color code

EXPULSOR DE GAS NE 16 x 2 GAS EJECTOR NE 16 x 2

Seguridad activa
Active safety



USAS

* F_{1_i} =

Fuerza final isotérmica
a 100% Cu
Isothermal end force
at 100% Cu

** F_{1_p} =

Fuerza final politrópica
a 100% Cu
Polytrophic end force
at 100% Cu

Recomendación de montaje
Assembly recommendation

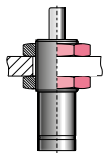

39DM16X2A Ver / See p. 334

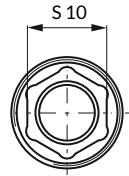
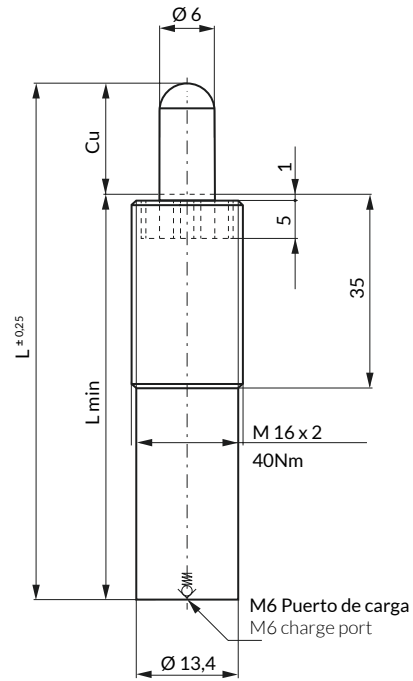

		°C 0 - 80	ΔP ± 0,33 % / °C	P max 150 bar	P min 10 bar	S 0,28 cm ²	SPM ~50 -100 (at 20°)	Velocidad Máx. Max Speed 1,8 m/s	Kit de mantenimiento Maintenance kit No disponible / Not available
--	--	-----------	-----------------------------	------------------	-----------------	---------------------------	--------------------------	--	--

Código Code	Cu	L	L min		PED 2014/68/EU
	mm	mm	mm		
NE 16 x 2-010	10	65	55	0,05	•
NE 16 x 2-020	20	85	65	0,06	•
NE 16 x 2-030	30	105	75	0,07	•
NE 16 x 2-040	40	125	85	0,07	•
NE 16 x 2-050	50	145	95	0,08	•
NE 16 x 2-060	60	165	105	0,08	•
NE 16 x 2-070	70	185	115	0,09	•
NE 16 x 2-080	80	205	125	0,10	•
NE 16 x 2-100	100	245	145	0,11	•
NE 16 x 2-125	125	295	170	0,12	•

P = Presión nominal de carga
P = Nominal charging pressure

Código color de fuerza Force color code	p	F0 Fuerza inicial Initial force	F _{1_i} Fuerza final* End force*	F _{1_p} Fuerza final** End force**
	bar	± 5% +20°C daN		
PR	12	4	1,56XF0	2,03XF0
GR	20	6	1,56XF0	2,03XF0
BU	40	11	1,56XF0	2,03XF0
RD	75	21	1,56XF0	2,03XF0
YW	150	42	1,56XF0	2,03XF0
BK	10-150	3-42	1,56XF0	2,03XF0

Forma de pedido: Código + Código de color de fuerza
How to order: Code + Force color code

EXPULSOR DE GAS NE 24 x 1,5 GAS EJECTOR NE 24 x 1,5

Seguridad activa
Active safety



USAS



OPAS

* F_{1i} =

Fuerza final isotérmica
a 100% Cu
Isothermal end force
at 100% Cu

** F_{1p} =

Fuerza final politrópica
a 100% Cu
Polytropic end force
at 100% Cu

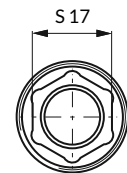
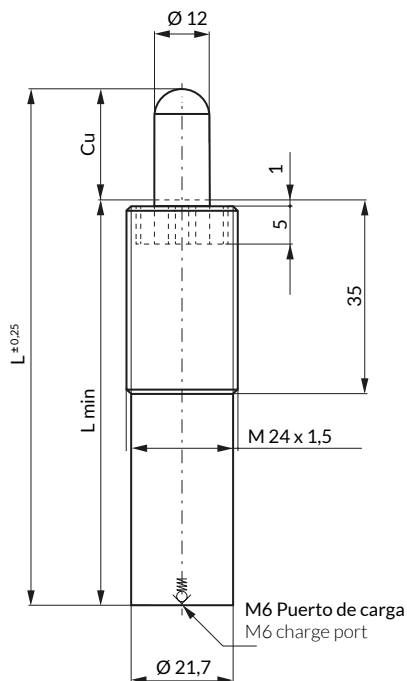

Recomendación de montaje
Assembly recommendation

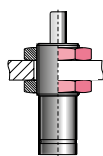

DM24

Ver / See p. 334

Norma / Standard: VDI 3400

		ΔP $\pm 0,33\% / ^\circ C$	P max 150 bar	P min 10 bar	S 0,28 cm ²	SPM ~50 -100 (at 20°)	Velocidad Máx. Max Speed 1,8 m/s	Kit de mantenimiento Maintenance kit No disponible / Not available
--	--	---------------------------------------	------------------	-----------------	---------------------------	--------------------------	--	--

Código Code	Cu	L	L min		PED 2014/68/EU
	mm	mm	mm		
NE 24 x 1,5-010	10	65	55	0,16	•
NE 24 x 1,5-020	20	85	65	0,18	•
NE 24 x 1,5-030	30	105	75	0,20	•
NE 24 x 1,5-040	40	125	85	0,23	•
NE 24 x 1,5-050	50	145	95	0,25	•
NE 24 x 1,5-060	60	165	105	0,27	•
NE 24 x 1,5-070	70	185	115	0,29	•
NE 24 x 1,5-080	80	205	125	0,30	•
NE 24 x 1,5-100	100	245	145	0,33	•
NE 24 x 1,5-125	125	295	170	0,35	•

P = Presión nominal de carga
P = Nominal charging pressure

Código color de fuerza Force color code	P	F ₀ Fuerza inicial Initial force	F _{1i} Fuerza final* End force*	F _{1p} Fuerza final** End force**
	bar	$\pm 5\% +20^\circ C$ daN		
GR	20	23	1,85XF0	2,53XF0
BU	40	45	1,85XF0	2,53XF0
RD	75	85	1,85XF0	2,53XF0
YW	150	170	1,85XF0	2,53XF0
BK	10-150	11-170	1,85XF0	2,53XF0

Forma de pedido: Código + Código de color de fuerza
How to order: Code + Force color code

EXPULSOR DE GAS NE 16 x 2 GAS EJECTOR NE 16 x 2

Seguridad activa
Active safety



USAS

* F_{1i} =

Fuerza final isotérmica
a 100% Cu
Isothermal end force
at 100% Cu

** F_{1p} =

Fuerza final politrópica
a 100% Cu
Polytropic end force
at 100% Cu

Recomendación de montaje
Assembly recommendation

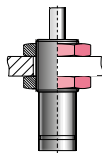

39DM16X2A Ver / See p. 334

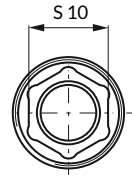
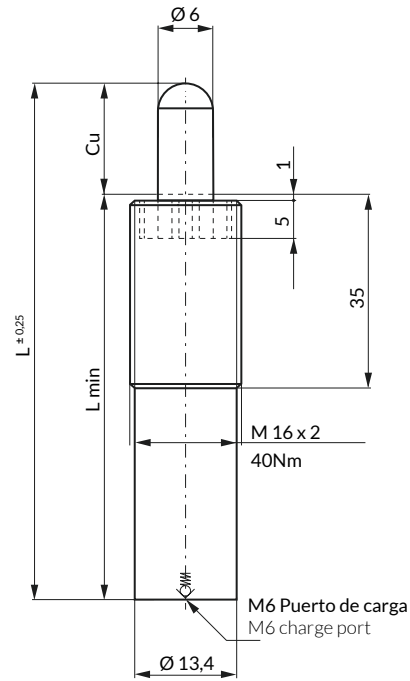

		°C 0 - 80	ΔP ± 0,33 % / °C	P max 150 bar	P min 10 bar	S 0,28 cm ²	SPM ~50 - 100 (at 20°)	Velocidad Máx. Max Speed 1,8 m/s	Kit de mantenimiento Maintenance kit No disponible / Not available
--	--	-----------	-----------------------------	------------------	-----------------	---------------------------	---------------------------	--	--

Código Code	Cu	L	L min		PED 2014/68/EU
	mm	mm	mm		
NE 16 x 2-010	10	65	55	0,05	•
NE 16 x 2-020	20	85	65	0,06	•
NE 16 x 2-030	30	105	75	0,07	•
NE 16 x 2-040	40	125	85	0,07	•
NE 16 x 2-050	50	145	95	0,08	•
NE 16 x 2-060	60	165	105	0,08	•
NE 16 x 2-070	70	185	115	0,09	•
NE 16 x 2-080	80	205	125	0,10	•
NE 16 x 2-100	100	245	145	0,11	•
NE 16 x 2-125	125	295	170	0,12	•

P = Presión nominal de carga
P = Nominal charging pressure

Código color de fuerza Force color code	P bar	F0 Fuerza inicial Initial force ± 5% +20°C	F _{1i} Fuerza final* End force*	F _{1p} Fuerza final** End force**
		daN		
PR	12	4	1,56XF0	2,03XF0
GR	20	6	1,56XF0	2,03XF0
BU	40	11	1,56XF0	2,03XF0
RD	75	21	1,56XF0	2,03XF0
YW	150	42	1,56XF0	2,03XF0
BK	10-150	3-42	1,56XF0	2,03XF0

Forma de pedido: Código + Código de color de fuerza
How to order: Code + Force color code

EXPULSOR DE GAS NE 24 x 1,5 GAS EJECTOR NE 24 x 1,5

Seguridad activa
Active safety



USAS



OPAS

* F_{1i} =

Fuerza final isotérmica
a 100% Cu
Isothermal end force
at 100% Cu

** F_{1p} =

Fuerza final politrópica
a 100% Cu
Polytropic end force
at 100% Cu

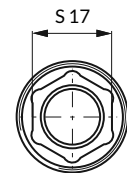
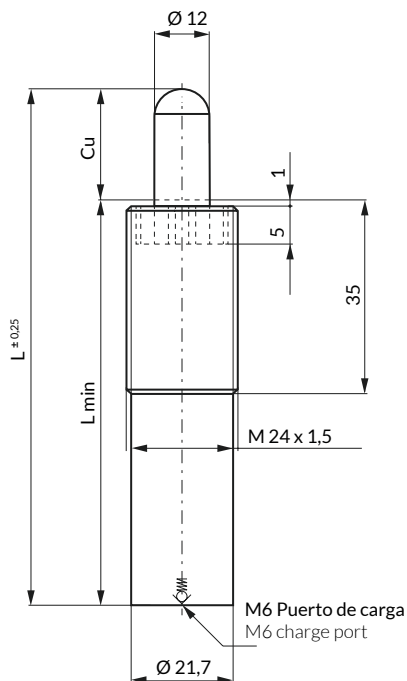

Recomendación de montaje
Assembly recommendation

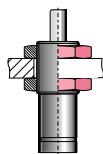

DM24

Ver / See p. 334

Norma / Standard: VDI 3400

		ΔP $\pm 0,33\% / ^\circ C$	P max 150 bar	P min 10 bar	S 0,28 cm ²	SPM ~50 -100 (at 20°)	Velocidad Máx. Max Speed 1,8 m/s	Kit de mantenimiento Maintenance kit No disponible / Not available
--	--	---------------------------------------	------------------	-----------------	---------------------------	--------------------------	--	--

Código Code	Cu	L	L min		PED 2014/68/EU
	mm	mm	mm		
NE 24 x 1,5-010	10	65	55	0,16	•
NE 24 x 1,5-020	20	85	65	0,18	•
NE 24 x 1,5-030	30	105	75	0,20	•
NE 24 x 1,5-040	40	125	85	0,23	•
NE 24 x 1,5-050	50	145	95	0,25	•
NE 24 x 1,5-060	60	165	105	0,27	•
NE 24 x 1,5-070	70	185	115	0,29	•
NE 24 x 1,5-080	80	205	125	0,30	•
NE 24 x 1,5-100	100	245	145	0,33	•
NE 24 x 1,5-125	125	295	170	0,35	•

P = Presión nominal de carga
P = Nominal charging pressure

Código color de fuerza Force color code	P	F ₀ Fuerza inicial Initial force	F _{1i} Fuerza final* End force*	F _{1p} Fuerza final** End force**
	bar	$\pm 5\% +20^\circ C$ daN		
GR	20	23	1,85XF0	2,53XF0
BU	40	45	1,85XF0	2,53XF0
RD	75	85	1,85XF0	2,53XF0
YW	150	170	1,85XF0	2,53XF0
BK	10-150	11-170	1,85XF0	2,53XF0

Forma de pedido: Código + Código de color de fuerza
How to order: Code + Force color code

EXPULSOR DE GAS NG 16 x 1,5 GAS EJECTOR NG 16 x 1,5

Seguridad activa
Active safety



USAS

* F_{1_i} =

Fuerza final isotérmica
a 100% Cu
Isothermal end force
at 100% Cu

** F_{1_p} =

Fuerza final politrópica
a 100% Cu
Polytrophic end force
at 100% Cu

Recomendación de montaje
Assembly recommendation

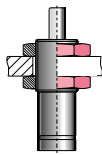

DM16

Ver / See p. 334

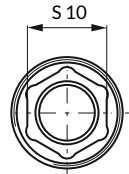
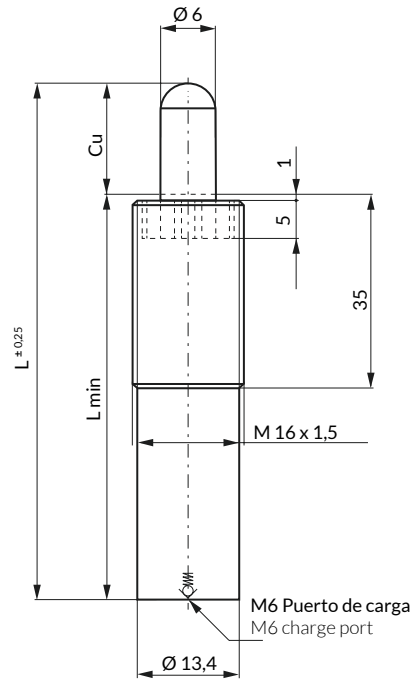

Norma / Standard: VDI 3400

		ΔP	P max	P min	S	SPM	Velocidad Máx.	Kit de mantenimiento
N ₂	°C 0 - 80	$\pm 0,33\% / ^\circ C$	150 bar	10 bar	0,28 cm ²	~50 -100 (at 20°)	Max Speed 1,8 m/s	Maintenance kit No disponible / Not available

Código Code	Cu	L	L min		PED 2014/68/EU
	mm	mm	mm		
NG 16 x 1,5-010	10	80	70	0,05	•
NG 16 x 1,5-020	20	100	80	0,06	•
NG 16 x 1,5-030	30	120	90	0,07	•
NG 16 x 1,5-040	40	140	100	0,07	•
NG 16 x 1,5-050	50	160	110	0,08	•
NG 16 x 1,5-060	60	180	120	0,08	•
NG 16 x 1,5-070	70	200	130	0,09	•
NG 16 x 1,5-080	80	220	140	0,10	•
NG 16 x 1,5-100	100	260	160	0,11	•
NE 16 x 1,5-125	125	295	170	0,12	•

P = Presión nominal de carga
P = Nominal charging pressure

Código color de fuerza Force color code	P	F0	F _{1_i}	F _{1_p}
		Fuerza inicial Initial force $\pm 5\% +20^\circ C$	Fuerza final* End force*	Fuerza final** End force**
	bar	daN		
GR	20	6	1,39XF0	1,67XF0
BU	40	11	1,39XF0	1,67XF0
RD	75	21	1,39XF0	1,67XF0
YW	150	42	1,39XF0	1,67XF0
BK	10-150	3-42	1,39XF0	1,67XF0

Forma de pedido: Código + Código de color de fuerza
How to order: Code + Force color code

EXPULSOR DE GAS NG 24 x 1,5 GAS EJECTOR NG 24 x 1,5

Seguridad activa
Active safety



USAS



OPAS

* F_{1i} =

Fuerza final isotérmica
a 100% Cu
Isothermal end force
at 100% Cu

** F_{1p} =

Fuerza final politrópica
a 100% Cu
Polytropic end force
at 100% Cu

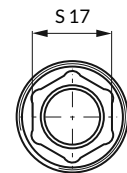
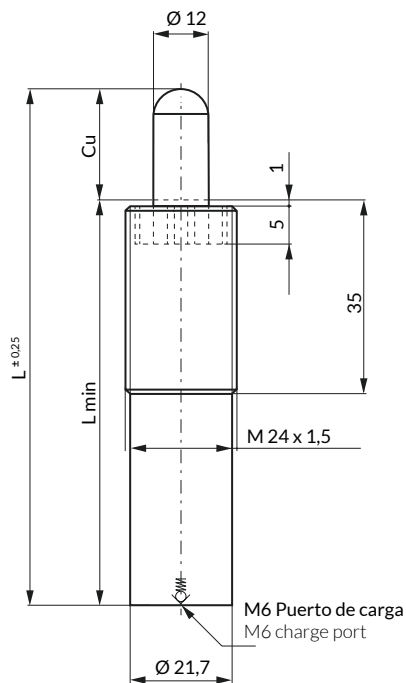

Recomendación de montaje
Assembly recommendation

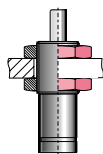

DM24

Ver / See p. 334

Norma / Standard: VDI 3400

		ΔP ±0,33% / °C	P max 150 bar	P min 10 bar	S 0,28 cm ²	SPM ~50 -100 (at 20°)	Velocidad Máx. Max Speed 1,8 m/s	Kit de mantenimiento Maintenance kit No disponible / Not available
--	--	---------------------------	------------------	-----------------	---------------------------	--------------------------	--	--

Código Code	Cu	L	L min		PED 2014/68/EU
	mm	mm	mm		
NG 24 x 1,5-010	10	80	70	0,15	•
NG 24 x 1,5-020	20	100	80	0,17	•
NG 24 x 1,5-030	30	120	90	0,19	•
NG 24 x 1,5-040	40	140	100	0,22	•
NG 24 x 1,5-050	50	160	110	0,24	•
NG 24 x 1,5-060	60	180	120	0,26	•
NG 24 x 1,5-070	70	200	130	0,28	•
NG 24 x 1,5-080	80	220	140	0,29	•
NG 24 x 1,5-100	100	260	160	0,31	•

P = Presión nominal de carga
P = Nominal charging pressure

Código color de fuerza Force color code	P	F0 Fuerza inicial Initial force	F _{1i} Fuerza final* End force*	F _{1p} Fuerza final** End force**
	bar	± 5% +20°C daN		
GR	20	23	1,55XF0	2,02XF0
BU	40	45	1,55XF0	2,02XF0
BR	60	85	1,55XF0	2,02XF0
RD	75	85	1,55XF0	2,02XF0
YW	150	170	1,55XF0	2,02XF0
BK	10-150	11-170	1,55XF0	2,02XF0

Forma de pedido: Código + Código de color de fuerza
How to order: Code + Force color code

CILINDRO M GAS SPRING M

STOCK

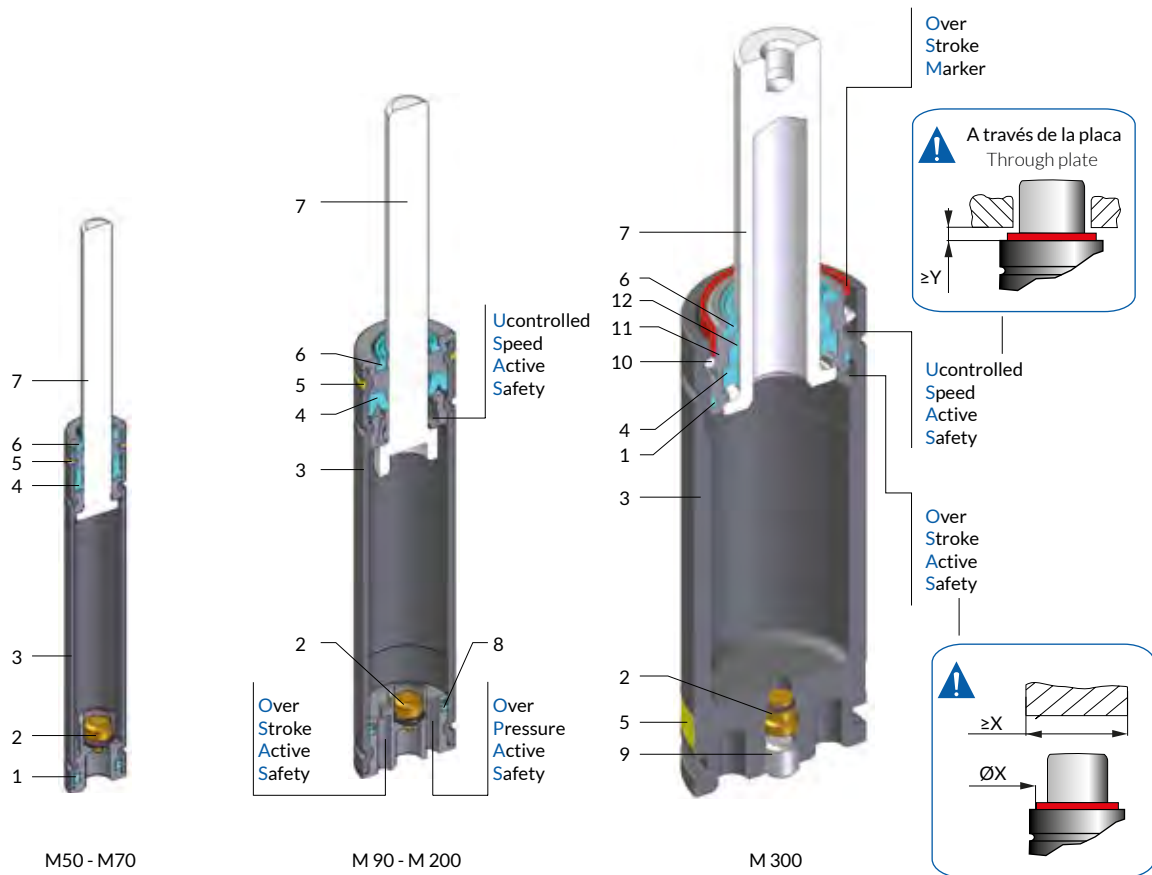





M50 - M70

M90 - M200

M300

Norma / Standard: VDI

Modelo Model	Cuerpo Ø Body Ø	Carrera Cu Stroke Cu	Fuerza inicial F0 Initial force F0					
	mm	mm	daN	OSAS	USAS	OPAS	SKUDO	SW (opcional)
M50	12	7 - 125	6 - 50	-	-	-	-	•
M70	15	7 - 125	8 - 70	-	-	-	-	•
M90	19	7 - 125	5 - 90	•	•	•	-	•
M200	25	7 - 125	17 - 200	•	•	•	-	•
M300	32	7 - 125	80 - 320	•	•	-	-	•

1	Anillo dual / Dual ring seal	7	Vástago (Nitrurado) / Rod (Nitrated Super finished)
2	Válvula / Valve	8	Anillo-O / O-ring
3	Cuerpo / Body	9	Tapón / Stopper
4	Retén / Rod seal	10	Anillo de retención / Retaining ring
5	Código de color de fuerza / Force color code	11	Casquillo / Bush
6	Retén / Rod wiper	12	Anillo guía / Guide ring

Versiones disponibles / Available versions



Código estándar / Standard code

Cilindro
GAS SPRING

Código estándar + W / Standard code + W

Cilindro
GAS SPRING
+
Rascafor secundario
Secondary wiper

Ver / See p. 338

MINI CILINDRO M 50 MINI GAS SPRING M 50



SW

Seguridad activa
Active safety

* F_{1_i} = Fuerza final isotérmica a 100% Cu
Isothermal end force at 100% Cu

** F_{1_p} = Fuerza final politrópica a 100% Cu
Polytropic end force at 100% Cu

Connectable with hoses
Linkable with hoses

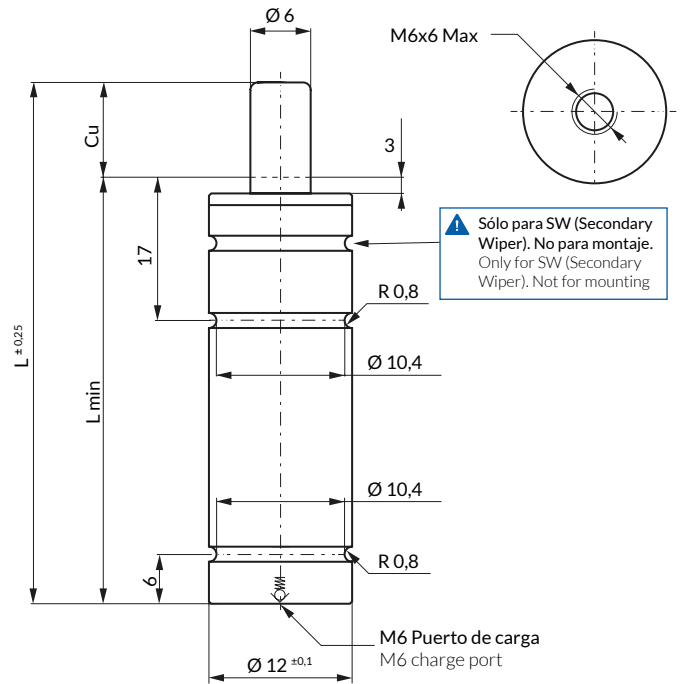

Recomendación de montaje / Assembly recommendation

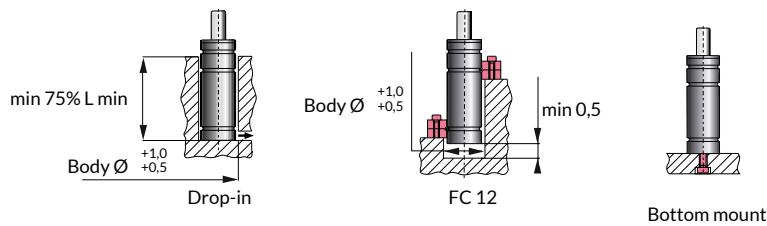

		ΔP	P max	P min	S	SPM	Velocidad Máx. Max Speed	Kit de mantenimiento Maintenance kit
N ₂	°C 0 - 80	$\pm 0,33\% / ^\circ C$	180 bar	20 bar	0,28 cm ²	~100 -150 (at 20°)	1,8 m/s	No disponible / Not available

Código Code	Cu	L	L min	F0 Fuerza inicial Initial force	F _{1_i} Fuerza final* End force*	V0		
	mm	mm	mm	daN		cm ³	~Kg	2014/68/EU
M 50-007	7	56	49	1,34XF0	1,56XF0	-	0,03	•
M 50-010	10	62	52	1,41XF0	1,67XF0	-	0,03	•
M 50-013	12,7	67,4	54,7	1,44XF0	1,72XF0	-	0,03	•
M 50-015	15	72	57	1,48XF0	1,79XF0	-	0,03	•
M 50-019	19	80	61	1,52XF0	1,85XF0	-	0,03	•
M 50-025	25	92	67	1,56XF0	1,92XF0	-	0,03	•
M 50-038	38	118	80	1,61XF0	2,01XF0	-	0,04	•
M 50-050	50	142	92	1,63XF0	2,05XF0	-	0,05	•
M 50-063	63,5	172	108,5	1,61XF0	2,01XF0	-	0,06	•
M 50-075	75	195	120	1,63XF0	2,04XF0	-	0,06	•
M 50-080	80	205	125	1,63XF0	2,05XF0	-	0,07	•
M 50-100	100	245	145	1,65XF0	2,08XF0	-	0,08	•
M 50-125	125	295	170	1,67XF0	2,11XF0	-	0,09	•

P = Presión nominal de carga
P = Nominal charging pressure

Código color de fuerza Force color code	p	F0 Fuerza inicial Initial force
	bar	daN
GR	45	13
BU	90	25
RD	135	38
YW	180	50
BK	20-180	6-50

Forma de pedido: Código + Código de color de fuerza
How to order: Code + Force color code

CILINDRO M 70 GAS SPRING M 70



SW

Seguridad activa
Active safety

*F_{1i}=

Fuerza final isotérmica
a 100% Cu
Isothermal end force
at 100% Cu

**F_{1p}=

Fuerza final politrópica
a 100% Cu
Polytrophic end force
at 100% Cu

Connectable con tubos
Linkable with hoses



Recomendación de montaje / Assembly recommendation

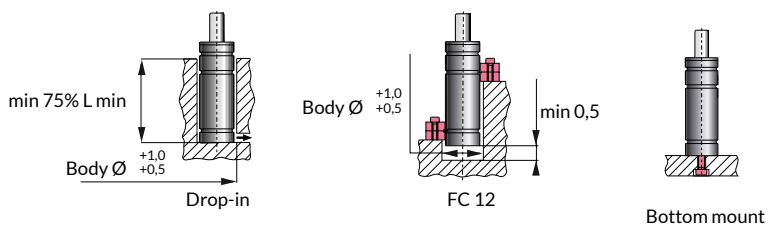
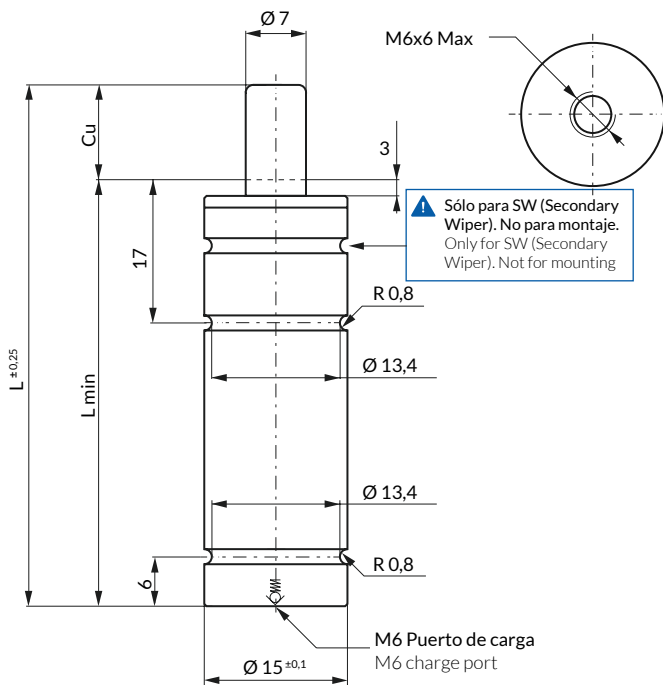

Ver / See p. 325

		ΔP	P max	P min	S	SPM	Velocidad Máx.	Kit de mantenimiento
N ₂	°C 0 - 80	± 0,33 % / °C	180 bar	20 bar	0,28 cm ²	~100 - 150 (at 20°)	Max Speed 1,8 m/s	Maintenance kit No disponible / Not available

Código Code	Cu	L	L min	F ₀ Fuerza inicial Initial force	F _{1i} Fuerza final* End force*	V ₀	
	mm	mm	mm	daN	cm ³	~Kg	
M70 - 007	7	56	49	1,28 x F ₀	1,47 x F ₀	-	0,04
M70 - 010	10	62	52	1,34 x F ₀	1,56 x F ₀	-	0,05
M70 - 013	12,7	67,4	54,7	1,37 x F ₀	1,61 x F ₀	-	0,05
M70 - 015	15	72	57	1,40 x F ₀	1,66 x F ₀	-	0,05
M70 - 019	19	80	61	1,43 x F ₀	1,72 x F ₀	-	0,05
M70 - 025	25	92	67	1,47 x F ₀	1,78 x F ₀	-	0,06
M70 - 038	38	118	80	1,51 x F ₀	1,85 x F ₀	-	0,07
M70 - 050	50	142	92	1,54 x F ₀	1,89 x F ₀	-	0,08
M70 - 063	63,5	172	108,5	1,52 x F ₀	1,87 x F ₀	-	0,09
M70 - 075	75	195	120	1,54 x F ₀	1,89 x F ₀	-	0,10
M70 - 080	80	205	125	1,54 x F ₀	1,90 x F ₀	-	0,10
M70 - 100	100	245	145	1,56 x F ₀	1,93 x F ₀	-	0,12
M70 - 125	125	295	170	1,57 x F ₀	1,95 x F ₀	-	0,14

P = Presión nominal de carga
P = Nominal charging pressure

Código color de fuerza Force color code	p	F ₀ Fuerza inicial Initial force
	bar	daN
GR	45	18
BU	90	35
RD	135	50
YW	180	70
BK	20-180	8-70

Forma de pedido: Código + Código de color de fuerza
How to order: Code + Force color code

CILINDRO M 90 GAS SPRING M 90



SW

Seguridad activa
Active safety



OSAS



USAS



OPAS

*F_{1i} =

Fuerza final isotérmica a 100% Cu
Isothermal end force at 100% Cu

**F_{1p} =

Fuerza final politrópica a 100% Cu
Polytropic end force at 100% Cu

Connectable con tubos
Linkable with hoses



easu
MANIFOLD

Recomendación de montaje / Assembly recommendation

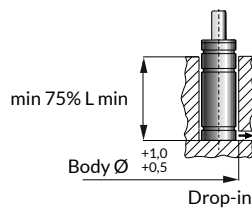
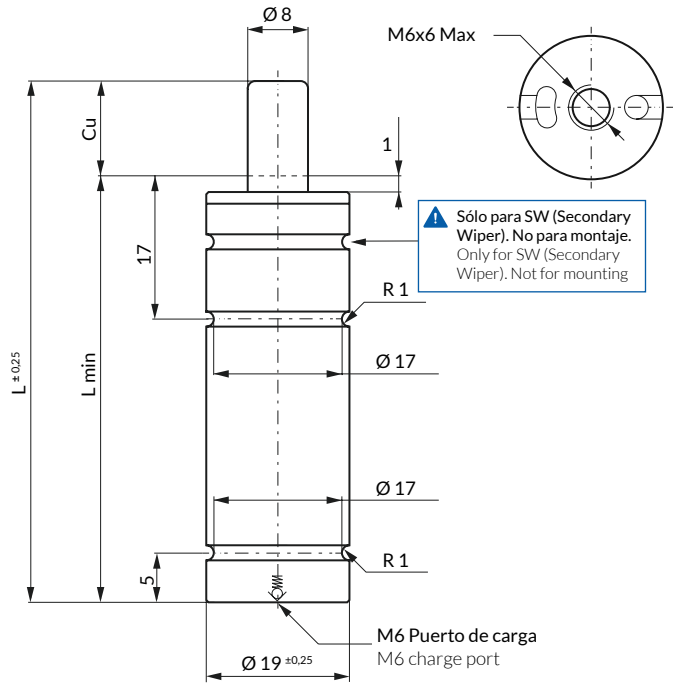

Drop-in

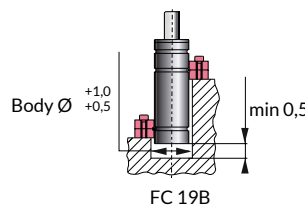

FC 19B
FCC 19A

Bottom mount

Norma / Standard: ISO 11901-1, VDI 3003-Blatt 2

Ver / See p. 325

N ₂	°C 0 - 80	ΔP ± 0,33 % / °C	P max 180 bar	P min 10 bar	S 0,50 cm ²	SPM ~100 -150 (at 20°)	Velocidad Máx. Max Speed 1,8 m/s	Kit de mantenimiento Maintenance kit No disponible / Not available
----------------	-----------	-----------------------------	------------------	-----------------	---------------------------	---------------------------	--	--

Código Code	Cu	L	L min	F0 Fuerza inicial Initial force	F _{1i} Fuerza final* End force*	V0		PED 2014/68/EU
	mm	mm	mm	daN	cm ³			
M90 - 007	7	56	49	1,21 x F0	1,39 x F0	-	0,07	•
M90 - 010	10	62	52	1,25 x F0	1,44 x F0	-	0,07	•
M90 - 013	12,7	67,4	54,7	1,27 x F0	1,48 x F0	-	0,08	•
M90 - 015	15	72	57	1,28 x F0	1,5 x F0	-	0,08	•
M90 - 025	25	92	67	1,32 x F0	1,57 x F0	-	0,09	•
M90 - 038	38,1	118,2	80,1	1,35 x F0	1,6 x F0	-	0,11	•
M90 - 050	50	142	92	1,36 x F0	1,62 x F0	-	0,12	•
M90 - 063	63,5	172	108,5	1,36 x F0	1,62 x F0	-	0,14	•
M90 - 080	80	205	125	1,37 x F0	1,64 x F0	-	0,15	•
M90 - 100	100	245	145	1,37 x F0	1,65 x F0	-	0,17	•
M90 - 125	125	295	170	1,38 x F0	1,66 x F0	-	0,20	•

P = Presión nominal de carga
P = Nominal charging pressure

Código color de fuerza Force color code	p	F0 Fuerza inicial Initial force
	bar	± 5% +20°C daN
OR	10	5
PR	20	10
GR	60	30
BU	100	50
RD	140	70
YW	180	90
BK	10-180	5-90

Forma de pedido: Código + Código de color de fuerza
How to order: Code + Force color code

CILINDRO M 200 GAS SPRING M 200



Seguridad activa
Active safety



* F_{1i} =

Fuerza final isotérmica a 100% Cu
Isothermal end force at 100% Cu

** F_{1p} =

Fuerza final politrópica a 100% Cu
Polytrophic end force at 100% Cu

Connectable with hoses
Linkable with hoses

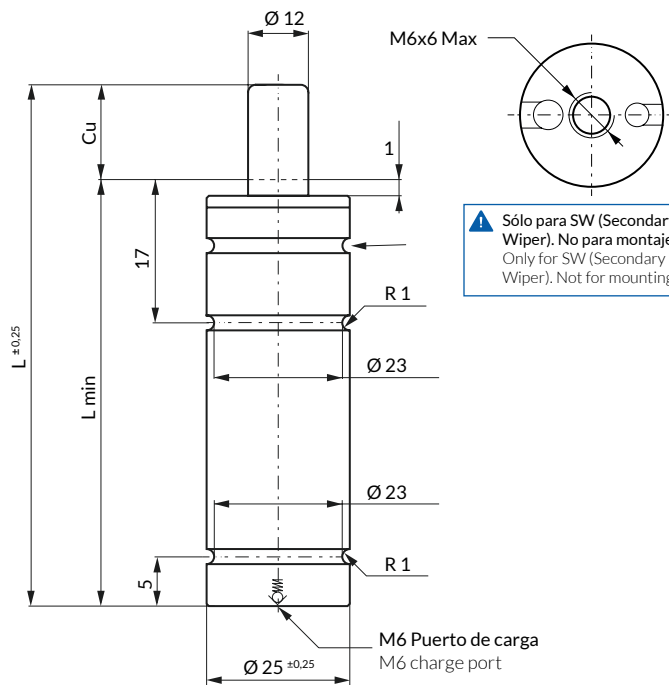

▲ Sólo para SW (Secondary Wiper). No para montaje. Only for SW (Secondary Wiper). Not for mounting

Recomendación de montaje / Assembly recommendation

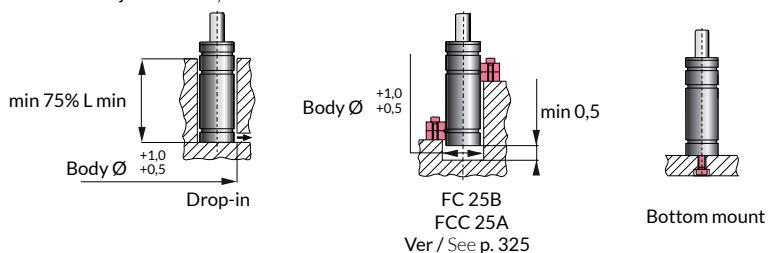

Norma / Standard: ISO 11901-1, VDI 3003-Blatt 2

N ₂	°C 0 - 80	ΔP ± 0,33 % / °C	P max 180 bar	P min 10 bar	S 1,13 cm ²	SPM ~50 - 80 (at 20°)	Velocidad Máx. Max Speed 1,8 m/s	Kit de mantenimiento Maintenance kit No disponible / Not available
----------------	-----------	-----------------------------	------------------	-----------------	---------------------------	--------------------------	--	--

Código Code	Cu	L	L min	F0 Fuerza inicial Initial force	F _{1i} Fuerza final* End force*	V0		PED 2014/68/EU
	mm	mm	mm	daN	cm ³			
M200-007	7	56	49	1,30 x F0	1,50 x F0	-	0,12	•
M200-010	10	62	52	1,34 x F0	1,57 x F0	-	0,13	•
M200-013	12,7	67,4	54,7	1,37 x F0	1,62 x F0	-	0,13	•
M200-015	15	72	57	1,38 x F0	1,64 x F0	-	0,14	•
M200-016	16	74	58	1,39 x F0	1,65 x F0	-	0,14	•
M200-025	25	92	67	1,43 x F0	1,72 x F0	-	0,16	•
M200-038	38,1	118,2	80,1	1,46 x F0	1,77 x F0	-	0,19	•
M200-050	50	142	92	1,47 x F0	1,79 x F0	-	0,20	•
M200-063	63,5	172	108,5	1,48 x F0	1,81 x F0	-	0,23	•
M200-080	80	205	125	1,49 x F0	1,83 x F0	-	0,26	•
M200-100	100	245	145	1,50 x F0	1,83 x F0	-	0,30	•
M200-125	125	295	170	1,50 x F0	1,84 x F0	-	0,34	•

P = Presión nominal de carga
P = Nominal charging pressure

Código color Force color code	p	F0 Fuerza inicial Initial force
	bar	daN
OR	15	17
PR	25	28
GR	45	50
BU	90	100
RD	135	150
YW	180	200
BK	10-180	11-200

Forma de pedido: Código + Código de color de fuerza
How to order: Code + Force color code

CILINDRO M 300 GAS SPRING M 300



SW

Seguridad activa
Active safety



OSAS



USAS

* F_{1i} =

Fuerza final isotérmica a 100% Cu
Isothermal end force at 100% Cu

** F_{1p} =

Fuerza final politrópica a 100% Cu
Polytropic end force at 100% Cu

Connectable con tubos
Linkable with hoses

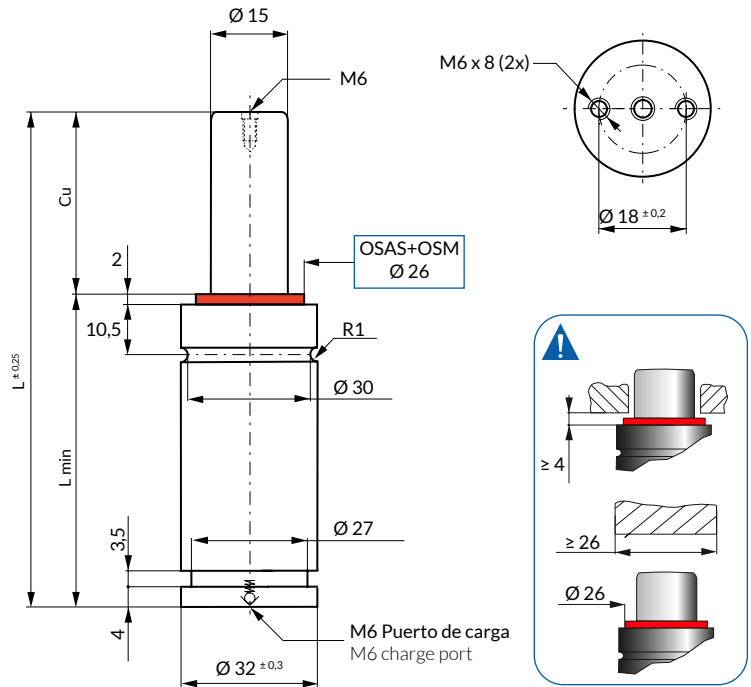

Recomendación de montaje / Assembly recommendation

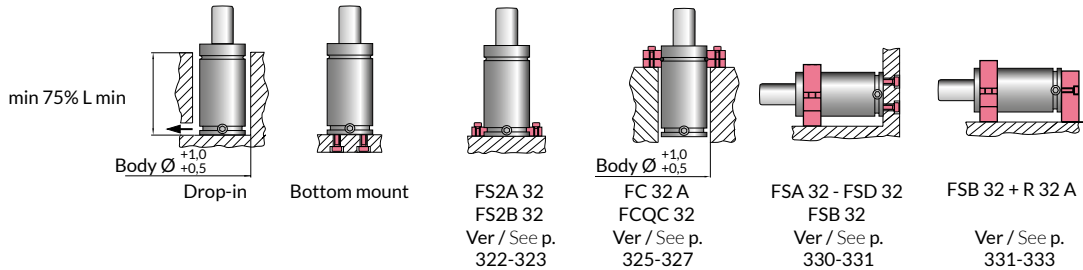

		ΔP	P max	P min	S	SPM	Velocidad Máx.	Kit de mantenimiento
N ₂	°C 0 - 80	± 0,33 % / °C	180 bar	10 bar	1,77 cm ²	~50 - 80 (at 20°)	Max Speed 1,8 m/s	Maintenance kit No disponible / Not available

Código Code	Cu	L	L min	F0 Fuerza inicial Initial force	F _{1i} Fuerza final* End force*	V0	
	mm	mm	mm	daN	cm ³	~Kg	
M300-007	7	56	49	1,17 x F0	1,30 x F0	-	•
M300-010	10	62	52	1,21 x F0	1,37 x F0	-	•
M300-013	12,7	67,4	54,7	1,24 x F0	1,41 x F0	-	•
M300-015	15	72	57	1,26 x F0	1,44 x F0	-	•
M300-025	25	92	67	1,32 x F0	1,53 x F0	-	•
M300-038	38	118	80	1,36 x F0	1,60 x F0	-	•
M300-050	50	142	92	1,38 x F0	1,64 x F0	-	•
M300-063	63,5	172	108,5	1,38 x F0	1,63 x F0	-	•
M300-080	80	205	125	1,40 x F0	1,66 x F0	-	•
M300-100	100	245	145	1,41 x F0	1,68 x F0	-	•
M300-125	125	295	170	1,42 x F0	1,70 x F0	-	•

P = Presión nominal de carga
P = Nominal charging pressure

Código color de fuerza Force color code	p	F0 Fuerza inicial Initial force
	bar	daN
GR	45	80
BU	90	160
RD	135	240
YW	180	320
BK	10-180	18-320

Forma de pedido: Código + Código de color de fuerza
How to order: Code + Force color code



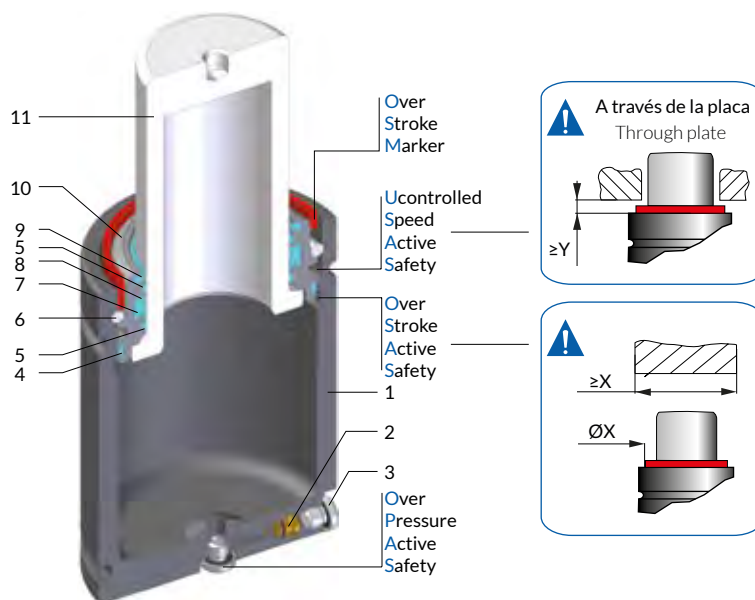

CILINDRO RV GAS SPRING RV

Mínima altura, máxima fuerza / Minimum height, maximum force

STOCK



Norma / Standard: ISO, VDI

Modelo Model	Cuerpo Ø Body Ø	Carrera Cu Stroke Cu	Fuerza inicial F0 Initial force F0					
	mm	mm	daN	OSAS	USAS	OPAS	SKUDO	SW (opcional)
RV 170	19	7 - 125	170	•	•	•	-	•
RV 320	25	7 - 125	320	•	•	•	-	•
RV350	32	10 - 125	360	•	•	•	-	•
RV 500	38	10 - 125	470	•	•	•	-	•
RV 750	45	10 - 125	740	•	•	•	-	•
RV 1000	50	10 - 125	920	•	•	•	-	•
RV 1200	50	10 - 125	1060	•	•	•	-	•
RV 1500	63	10 - 125	1530	•	•	•	-	•
RV 2400	75	10 - 125	2385	•	•	•	-	•
RV 4200	95	16 - 125	4240	•	•	•	-	•
RV 6600	120	16 - 125	6630	•	•	•	-	•
RV 9500	150	19 - 125	9540	•	•	•	-	•
RV 12000	150	19 - 125	11780	•	•	•	-	•
RV 20000	195	19 - 125	19910	•	•	•	-	•

1	Cuerpo / Body	7	Retén / Rod seal
2	Válvula / Valve	8	Anillo antiextrusión / Back-up ring
3	Tapón / Plug	9	Rascador / Rod wiper
4	Anillo dual / Dual ring seal	10	Casquillo / Bush
5	Casquillo guía / Guide ring	11	Vástago (nitruado) / Rod (nitrited super finished)
6	Anillo de retención / Retaining ring		

Versiones disponibles / Available versions



Código estándar / Standard code



Cilindro
GAS SPRING



Código estándar+W / Standard code+W



Cilindro
GAS SPRING
+
Rascafor secundario
Secondary wiper



Ver / See p. 338



Código estándar+N / Standard code+N



Conectable
Linkable

Ver / See p. 335



Código estándar+N-W / Standard code+N-W



Conectable
Linkable
+
Rascafor secundario
Secondary wiper



Ver / See p.
335-338



Código estándar+E / Standard code+E



Easy
Manifold

Ver / See p. 336



Código estándar+E-W / Standard code+E-W



Easy
Manifold
+
Rascafor secundario
Secondary wiper



Ver / See p.
336-338

CILINDRO RV 170 GAS SPRING RV 170



SW

Seguridad activa
Active safety



OSAS



USAS



OPAS

* F_{1i} =

Fuerza final isotérmica
a 100% Cu
Isothermal end force
at 100% Cu

** F_{1p} =

Fuerza final politrópica
a 100% Cu
Polytrophic end force
at 100% Cu



Connectable con tubos
Linkable with hoses

Recomendación de montaje / Assembly recommendation

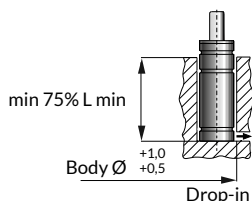

Drop-in

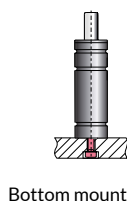

Bottom mount

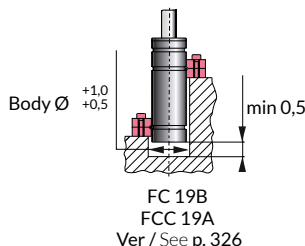

FC 19B
FCC 19A
Ver / See p. 326

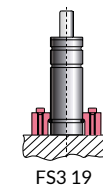

FS3 19
Ver / See p. 324

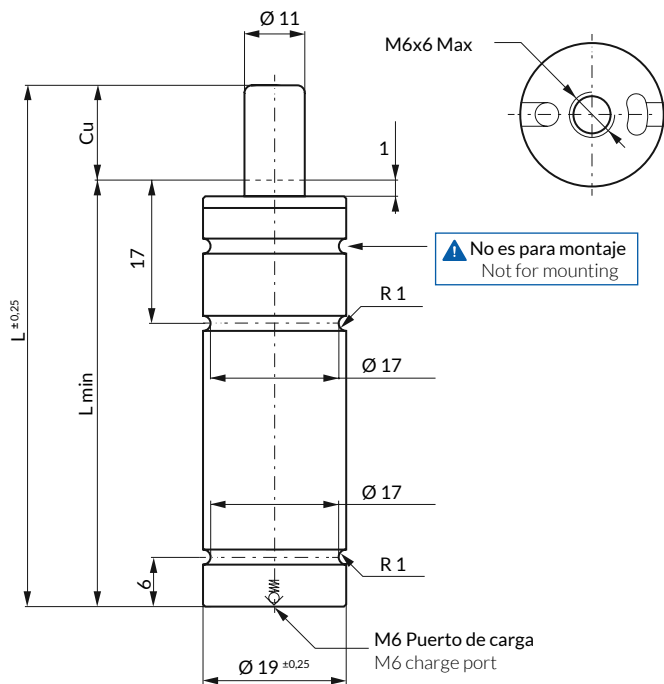

Norma / Standard: ISO 11901-3, VDI 3003-Blatt 3

	N ₂		°C 0 - 80	ΔP	$\pm 0,33\% / ^\circ C$	P max	180 bar	P min	20 bar	S	0,95 cm ²	SPM	~40 - 100 (at 20°)	Velocidad Máx.	Max Speed 1,8 m/s	Kit de mantenimiento	Maintenance kit No disponible / Not available
--	----------------	--	-----------	------------	-------------------------	-------	---------	-------	--------	---	----------------------	-----	--------------------	----------------	----------------------	----------------------	--

Código Code	Cu	L	L min	F0 Fuerza inicial Initial force	F _{1i} Fuerza final* End force*	F _{1p} Fuerza final* End force*	V0		PED 2014/68/EU
	mm	mm	mm	daN	mm	~Kg	cm ³		
RV 170-007	7	44	37		274	320	2,0	0,06	•
RV 170-010	10	50	40		285	337	3,0	0,06	•
RV 170-013	13	56	43		292	348	4,0	0,07	•
RV 170-015	15	60	45		296	353	4,0	0,07	•
RV 170-019	19	68	49	170	301	361	5,0	0,07	•
RV 170-025	25	80	55	± 5%	306	369	7,0	0,08	•
RV 170-032	32	94	62		310	374	8,0	0,09	•
RV 170-038	38	106	68	180bar	312	378	10,0	0,09	•
RV 170-050	50	130	80		315	382	13,0	0,11	•
RV 170-063	63	156	93	+20°C	317	385	16,0	0,12	•
RV 170-075	75	185	110		318	387	19,0	0,14	•
RV 170-080	80	195	115		319	388	21,0	0,14	•
RV 170-100	100	235	135		320	390	25,0	0,16	•
RV 170-125	125	285	160		321	391	31,0	0,19	•

Forma de pedido: Código
How to order: Code

CILINDRO RV 320 GAS SPRING RV 320



SW

Seguridad activa
Active safety

* F_{1i} =

Fuerza final isotérmica
a 100% Cu
Isothermal end force
at 100% Cu

** F_{1p} =

Fuerza final politrópica
a 100% Cu
Polytrophic end force
at 100% Cu

Connectable con tubos
Linkable with hoses



Recomendación de montaje / Assembly recommendation

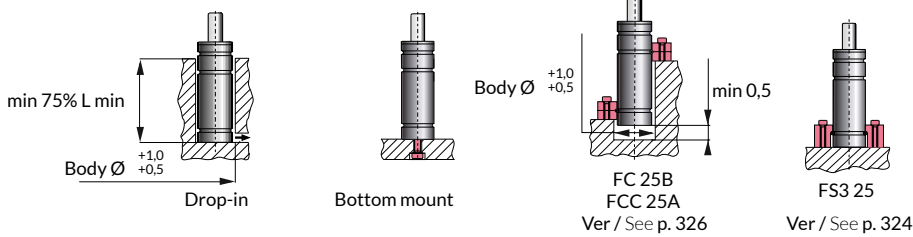
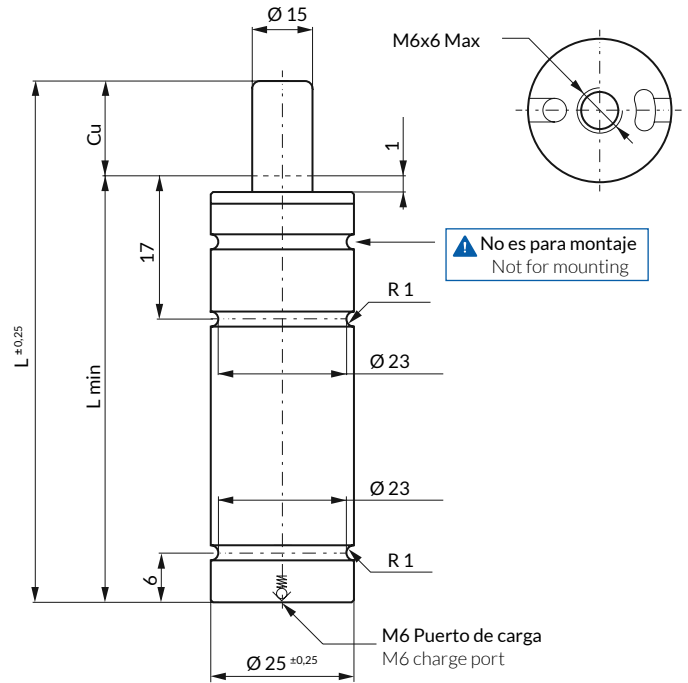

		ΔP	P max	P min	S	SPM	Velocidad Máx.	Kit de mantenimiento
N ₂	°C 0 - 80	± 0,33 % / °C	180 bar	20 bar	0,95 cm ²	~40 -100 (at 20°)	Max Speed 1,8 m/s	Maintenance kit No disponible / Not available

Código Code	Cu	L	L min	F0	F _{1i}	F _{1p}	V0		
	mm	mm	mm	Fuerza inicial Initial force	Fuerza final* End force*	Fuerza final* End force*			
RV 320-007	7	44	37	320 ± 5%	467	535	5,0	0,10	•
RV 320-010	10	50	40		491	569	6,0	0,10	•
RV 320-013	13	56	43		508	593	7,0	0,11	•
RV 320-015	15	60	45		516	606	8,0	0,11	•
RV 320-019	19	68	49		529	624	10,0	0,12	•
RV 320-025	25	80	55		542	643	13,0	0,13	•
RV 320-032	32	94	62		551	658	16,0	0,14	•
RV 320-038	38	106	68		557	667	19,0	0,15	•
RV 320-050	50	130	80		565	679	24,0	0,17	•
RV 320-063	63	156	93		571	687	30,0	0,19	•
RV 320-075	75	185	110	567	681	36,0	0,22	•	
RV 320-080	80	195	115	568	683	38,0	0,23	•	
RV 320-100	100	235	135	573	691	47,0	0,26	•	
RV 320-125	125	285	160	577	697	59,0	0,30	•	

Forma de pedido: Código
How to order: Code

CILINDRO RV 350 GAS SPRING RV 350



Seguridad activa
Active safety



OSAS



USAS



OPAS

*F_{1i} =

Fuerza final isotérmica
a 100% Cu
Isothermal end force
at 100% Cu

**F_{1p} =

Fuerza final politrópica
a 100% Cu
Polytrophic end force
at 100% Cu

OSAS + OSM = OVER STROKE + OVER STROKE
= ACTIVE SAVETY + MARKER

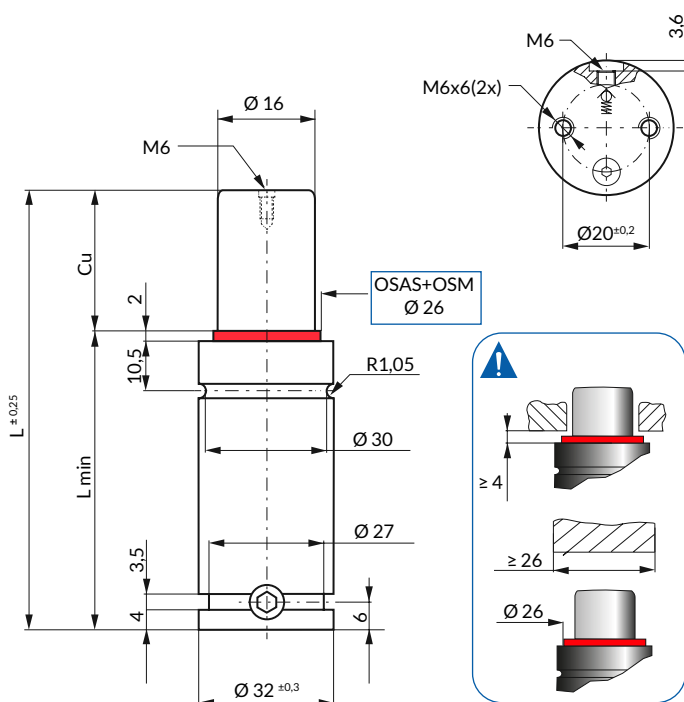

Recomendación de montaje / Assembly recommendation

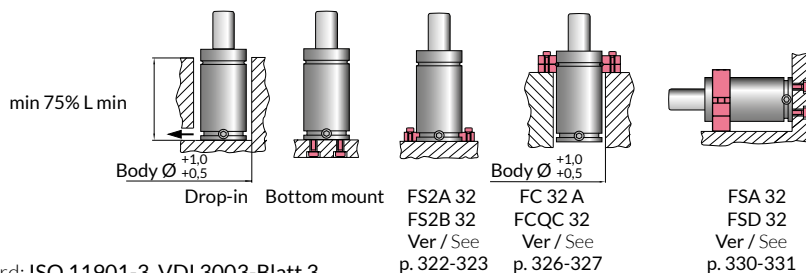

Norma / Standard: ISO 11901-3, VDI 3003-Blatt 3

		ΔP	P max	P min	S	SPM	Velocidad Máx.	Kit de mantenimiento
N ₂	°C 0 - 80	± 0,33 % / °C	180 bar	20 bar	2,01 cm ²	~20 -100 (at 20°)	Max Speed 1,8 m/s	Maintenance kit 39BMRV00350C

Código Code	Cu	L	L min	F0 Fuerza inicial Initial force	F _{1i} Fuerza final* End force*	F _{1p} Fuerza final* End force*	V0		PED 2014/68/EU
	mm	mm	mm	daN	mm	~Kg	cm ³		
RV 350-010	10	50	40	360 ± 5%	524	598	8,0	0,17	•
RV 350-013	13	56	43		538	617	10,0	0,18	•
RV 350-016	16	62	46		547	631	12,0	0,19	•
RV 350-019	19	68	49		555	642	13,0	0,19	•
RV 350-025	25	80	55		565	656	17,0	0,21	•
RV 350-032	32	94	62		572	667	21,0	0,24	•
RV 350-038	38	106	68		577	674	25,0	0,26	•
RV 350-050	50	130	80		583	683	32,0	0,30	•
RV 350-063	63	156	93		587	689	40,0	0,34	•
RV 350-075	75	180	105		590	693	47,0	0,38	•
RV 350-080	80	190	110	591	694	50,0	0,39	•	
RV 350-100	100	230	130	593	698	62,0	0,46	•	
RV 350-125	125	280	155	595	701	77,0	0,54	•	

Forma de pedido: Código
How to order: Code

CILINDRO RV 500 GAS SPRING RV 500

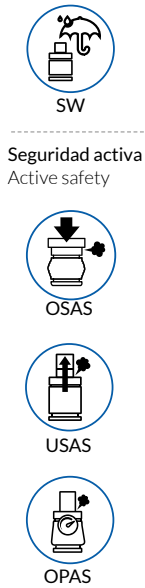

* F_{1i} = Fuerza final isotérmica a 100% Cu
Isothermal end force at 100% Cu

** F_{1p} = Fuerza final politrópica a 100% Cu
Polytrophic end force at 100% Cu

OSAS + OSM = OVER STROKE ACTIVE SAVETY + OVER STROKE MARKER

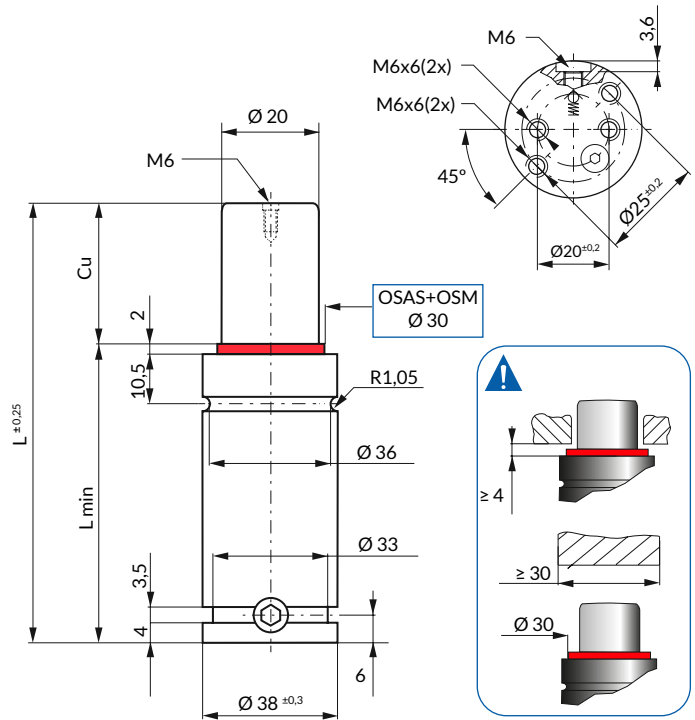

Recomendación de montaje / Assembly recommendation

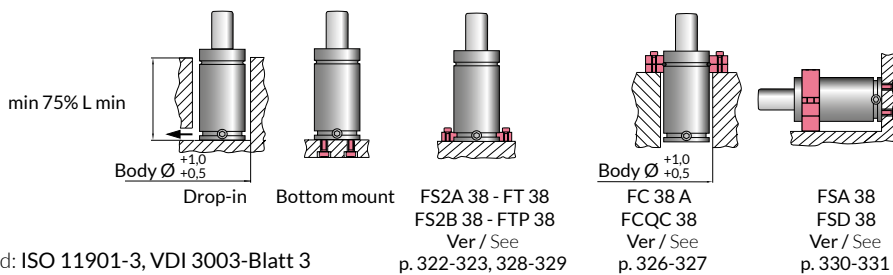

Norma / Standard: ISO 11901-3, VDI 3003-Blatt 3

		ΔP	P max	P min	S	SPM	Velocidad Máx.	Kit de mantenimiento
N ₂	°C 0 - 80	± 0,33 % / °C	150 bar	20 bar	3,14 cm ²	~20-100 (at 20°)	Max Speed 1,8 m/s	Maintenance kit 39BMRV00500C

Código Code	Cu	L	L min	F0	F _{1i}	F _{1p}	V0		PED 2014/68/EU	
	mm	mm	mm	Fuerza inicial Initial force	Fuerza final* End force*	Fuerza final* End force*				daN
RV 500-010	10	50	40	470 ± 5%	693	824	11,0	0,27	•	
RV 500-013	13	56	43		713	854	14,0	0,25	•	
RV 500-016	16	62	45		726	876	17,0	0,26	•	
RV 500-019	19	68	49		737	892	19,0	0,28	•	
RV 500-025	25	80	55		751	916	24,0	0,31	•	
RV 500-032	32	94	62		762	933	30,0	0,34	•	
RV 500-038	38	106	68		768	944	35,0	0,37	•	
RV 500-050	50	130	80		777	958	46,0	0,43	•	
RV 500-063	63	156	93		783	968	57,0	0,49	•	
RV 500-075	75	180	105		787	975	67,0	0,54	•	
RV 500-080	80	190	110	788	977	72,0	0,57	•		
RV 500-100	100	230	130	792	983	89,0	0,66	•		
RV 500-125	125	280	155	795	989	110,0	0,78	•		

Forma de pedido: Código
How to order: Code

CILINDRO RV 750 GAS SPRING RV 750



Seguridad activa
Active safety



* F_{1i} =

Fuerza final isotérmica
a 100% Cu
Isothermal end force
at 100% Cu

** F_{1p} =

Fuerza final politrópica
a 100% Cu
Polytrophic end force
at 100% Cu

OSAS + OSM = OVER STROKE ACTIVE SAFETY + OVER STROKE MARKER

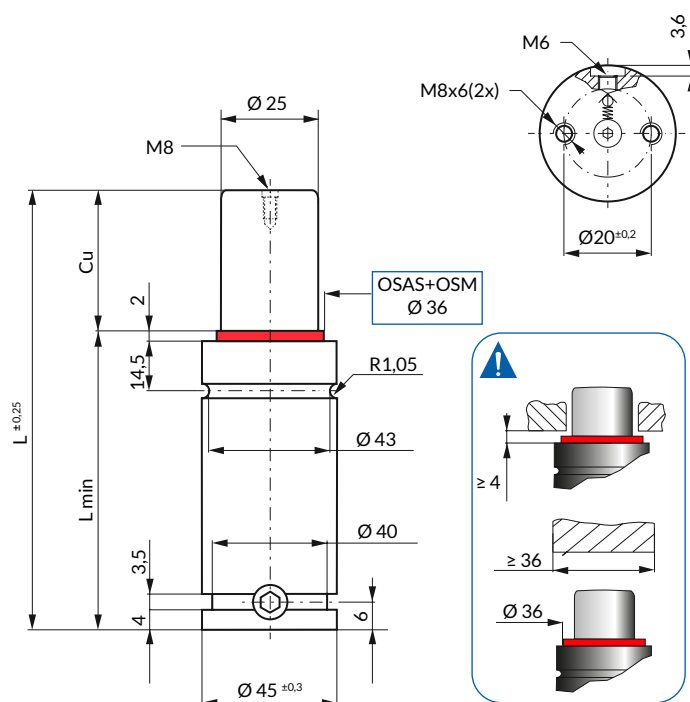

Recomendación de montaje / Assembly recommendation

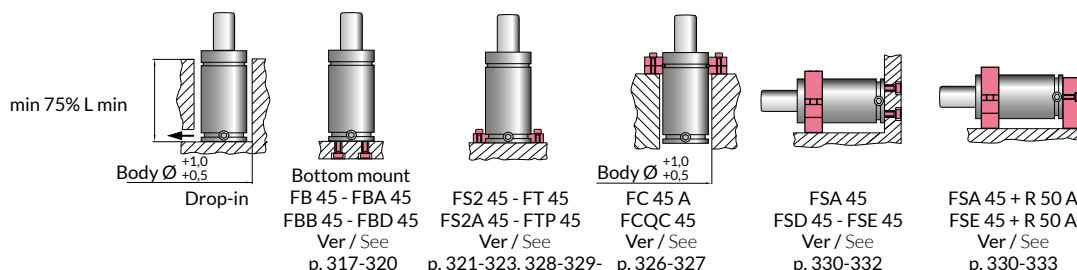

Norma / Standard: ISO 11901-3, VDI 3003-Blatt 3

		ΔP	P max	P min	S	SPM	Velocidad Máx.	Kit de mantenimiento
N ₂	°C 0 - 80	± 0,33 % / °C	150 bar	20 bar	4,91 cm ²	~20 - 100 (at 20°)	Max Speed 1,8 m/s	Maintenance kit 39BMRV00750C

Código Code	Cu	L	L min	F0 Fuerza inicial Initial force	F _{1i} Fuerza final* End force*	F _{1p} Fuerza final* End force*	V0		
	mm	mm	mm	daN	mm	~Kg	cm ³	~Kg	2014/68/EU
RV 750-010	10	52	42		1091	1298	18,0	0,36	•
RV 750-013	13	58	45		1125	1354	21,0	0,38	•
RV 750-016	16	64	48		1151	1395	25,0	0,40	•
RV 750-019	19	70	51		1170	1426	29,0	0,42	•
RV 750-025	25	82	57	740	1198	1471	37,0	0,45	•
RV 750-032	32	96	64	± 5%	1220	1506	46,0	0,50	•
RV 750-038	38	108	70		1232	1527	53,0	0,54	•
RV 750-050	50	132	82	150bar	1250	1556	68,0	0,61	•
RV 750-063	63	158	95		1262	1577	85,0	0,70	•
RV 750-075	75	182	107	+20°C	1270	1590	100,0	0,78	•
RV 750-080	80	192	112		1273	1594	107,0	0,81	•
RV 750-100	100	232	132		1281	1607	132,0	0,94	•
RV 750-125	125	282	157		1287	1618	164,0	1,10	•

Forma de pedido: Código
How to order: Code

CILINDRO RV 1000 GAS SPRING RV 1000



SW

Seguridad activa
Active safety



OSAS



USAS



OPAS

* F_{1i} =

Fuerza final isotérmica
a 100% Cu
Isothermal end force
at 100% Cu

** F_{1p} =

Fuerza final politrópica
a 100% Cu
Polytrophic end force
at 100% Cu

OSAS + OSM OVER STROKE ACTIVE SAVETY + OVER STROKE MARKER

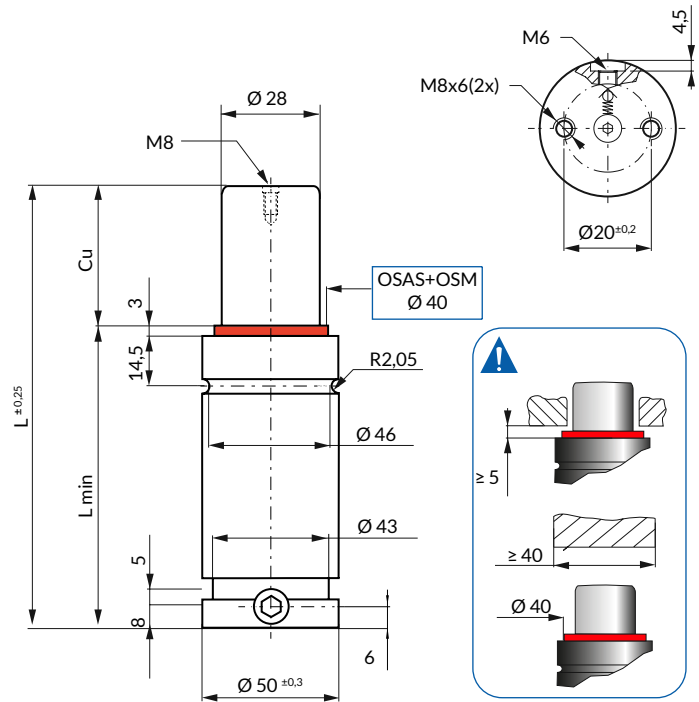

Recomendación de montaje / Assembly recommendation

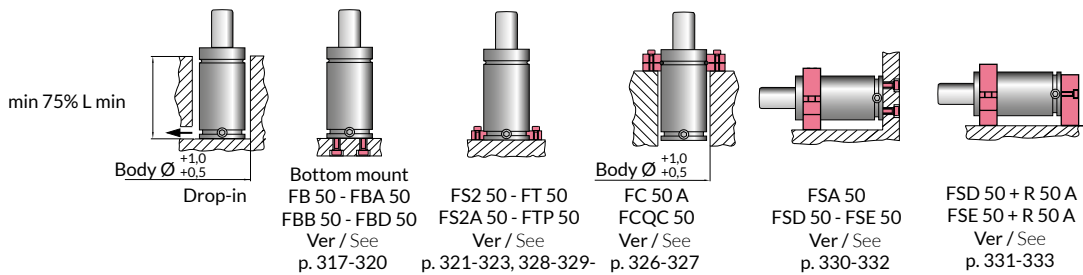

Norma / Standard: ISO 11901-3, VDI 3003-Blatt 3

		ΔP	P max	P min	S	SPM	Velocidad Máx.	Kit de mantenimiento
N ₂	°C 0 - 80	± 0,33% / °C	150 bar	20 bar	6,15 cm ²	~20 - 100 (at 20°)	Max Speed 1,8 m/s	Maintenance kit 39BMRV01000C

Código Code	Cu	L	L min	F0	F _{1i}	F _{1p}	V0		
	mm	mm	mm	Fuerza inicial Initial force	Fuerza final* End force*	Fuerza final* End force*			
RV 1000-010	10	58	48	920 ± 5%	1300	1523	25,0	0,49	•
RV 1000-013	13	64	51		1349	1599	29,0	0,51	•
RV 1000-016	16	70	54		1386	1658	34,0	0,54	•
RV 1000-019	19	76	57		1416	1705	39,0	0,56	•
RV 1000-025	25	88	63		1460	1775	48,0	0,61	•
RV 1000-032	32	102	70		1495	1832	59,0	0,67	•
RV 1000-038	38	114	76		1517	1868	69,0	0,72	•
RV 1000-050	50	138	88		1548	1919	88,0	0,81	•
RV 1000-063	63	164	101		1570	1955	108,0	0,92	•
RV 1000-075	75	188	113		1584	1978	127,0	1,01	•
RV 1000-080	80	198	118	1589	1986	135,0	1,05	•	
RV 1000-100	100	238	138	1603	2011	166,0	1,21	•	
RV 1000-125	125	288	163	1616	2031	205,0	1,41	•	

CILINDRO RV 1200 GAS SPRING RV 1200



SW

Seguridad activa
Active safety

* F₁ = Fuerza final isotérmica a 100% Cu
Isothermal end force at 100% Cu

** F_{1p} = Fuerza final politrópica a 100% Cu
Polytrophic end force at 100% Cu

OSAS + OSM = OVER STROKE ACTIVE SAVETY + OVER STROKE MARKER

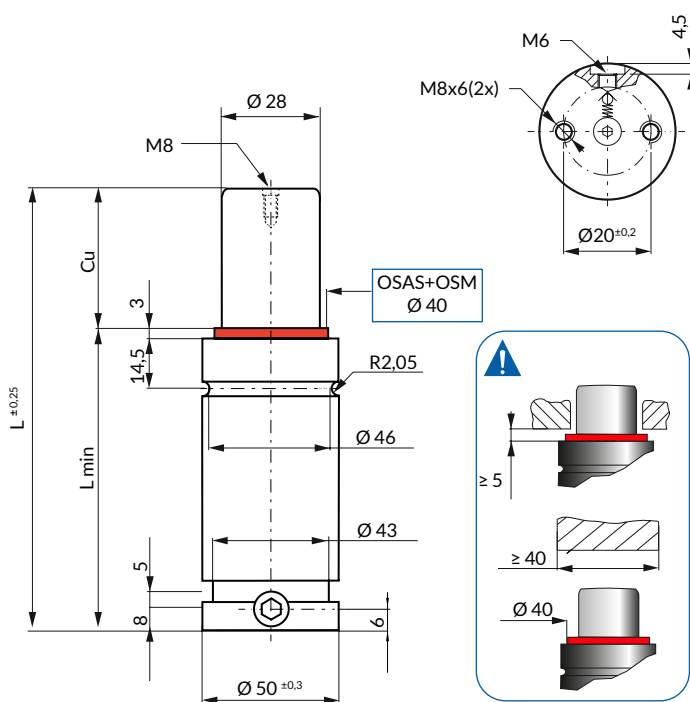

Recomendación de montaje / Assembly recommendation

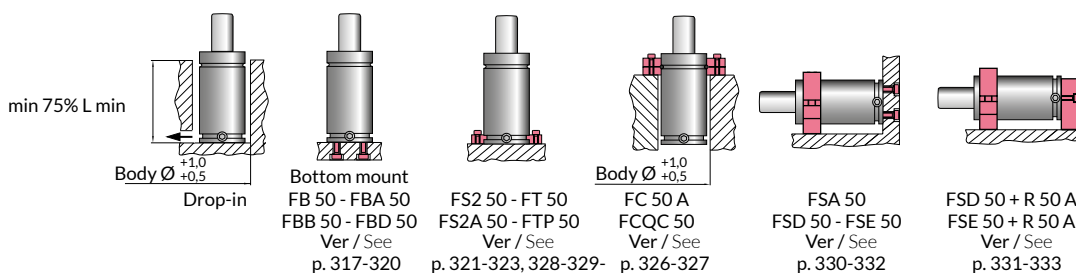

		ΔP	P max	P min	S	SPM	Velocidad Máx.	Kit de mantenimiento
N ₂	°C 0 - 80	± 0,33 % / °C	170 bar	20 bar	6,15 cm ²	~20 - 100 (at 20°)	Max Speed 1,8 m/s	Maintenance kit 39BMRV01000C

Código Code	Cu	L	L min	F0	F _{1i}	F _{1p}	V0		PED 2014/68/EU
	mm	mm	mm	Fuerza inicial Initial force	Fuerza final* End force*	Fuerza final* End force*			
RV 1200-010	10	58	48	1060 ± 5%	1494	1717	25,0	0,49	•
RV 1200-013	13	64	51		1553	1802	30,0	0,51	•
RV 1200-016	16	70	54		1597	1869	34,0	0,54	•
RV 1200-019	19	76	57		1633	1922	39,0	0,56	•
RV 1200-025	25	88	63		1685	2001	48,0	0,61	•
RV 1200-032	32	102	70		1728	1066	59,0	0,67	•
RV 1200-038	38	114	76		1754	2106	69,0	0,72	•
RV 1200-050	50	138	88		1791	2163	88,0	0,81	•
RV 1200-063	63	164	101		1817	2204	108,0	0,92	•
RV 1200-075	75	188	113		1834	2230	127,0	1,01	•
RV 1200-080	80	198	118	1840	2239	135,0	1,05	•	
RV 1200-100	100	238	138	1858	2267	166,0	1,21	•	
RV 1200-125	125	288	163	1873	2290	205,0	1,41	•	

Forma de pedido: Código
How to order: Code

CILINDRO RV 1500 GAS SPRING RV 1500



* F_{1i} = Fuerza final isotérmica a 100% Cu
Isothermal end force at 100% Cu

** F_{1p} = Fuerza final politrópica a 100% Cu
Polytropic end force at 100% Cu

OSAS + OSM = OVER STROKE + OVER STROKE = ACTIVE SAFETY MARKER



Recomendación de montaje / Assembly recommendation

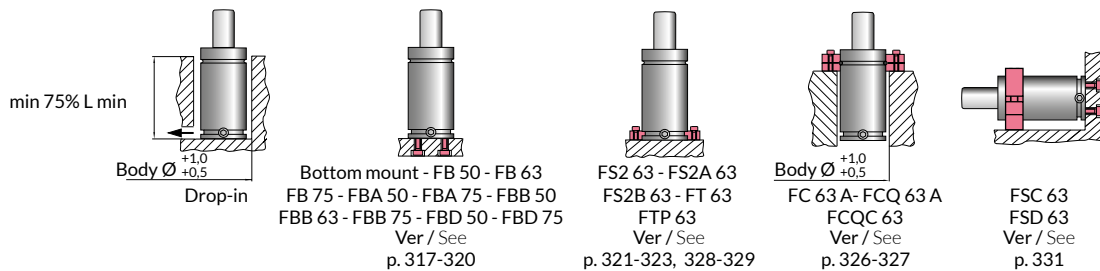
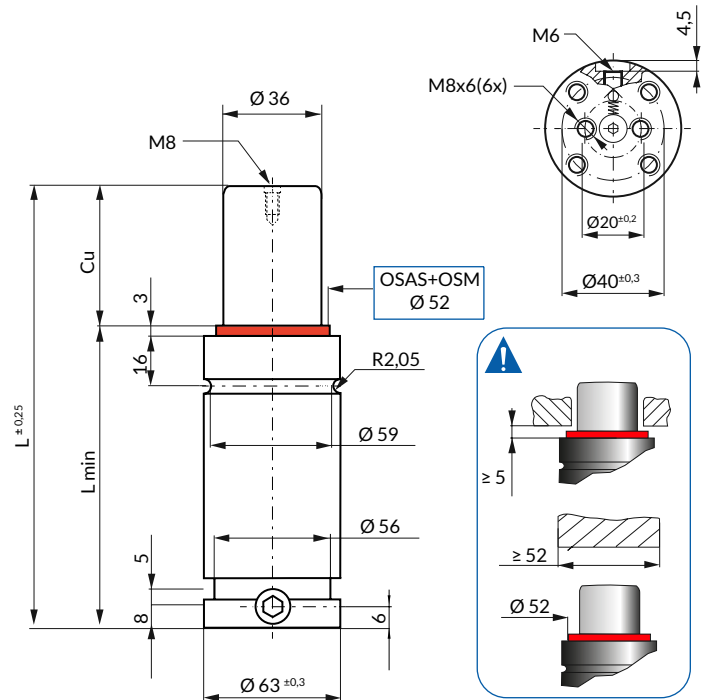

Norma / Standard: ISO 11901-3, VDI 3003-Blatt 3

		ΔP	P max	P min	S	SPM	Velocidad Max.	Kit de mantenimiento
N ₂	°C 0 - 80	± 0,33% / °C	150 bar	20 bar	10,18 cm ²	~20 - 100 (at 20°)	Max Speed 1,8 m/s	Maintenance kit 39BMRV01500C

Código Code	Cu	L	L min	F0 Fuerza inicial Initial force	F _{1i} Fuerza final* End force*	F _{1p} Fuerza final* End force*	V0		
	mm	mm	mm	daN	mm	~Kg	cm ³	~Kg	2014/68/EU
RV 1500-010	10	64	54		2074	2400	45,0	0,88	•
RV 1500-013	13	70	57		2152	2521	53,0	0,91	•
RV 1500-016	16	76	60		2213	2616	61,0	0,96	•
RV 1500-019	19	82	63	1530	2262	2693	69,0	0,99	•
RV 1500-025	25	94	69	± 5%	2336	2811	85,0	1,06	•
RV 1500-032	32	108	76		2397	2908	103,0	1,14	•
RV 1500-038	38	120	82	150bar	2435	2971	119,0	1,21	•
RV 1500-050	50	144	94		2490	3059	151,0	1,36	•
RV 1500-063	63	170	107	+20°C	2529	3123	186,0	1,52	•
RV 1500-075	75	194	119		2555	3165	217,0	1,66	•
RV 1500-080	80	204	124		2563	3180	231,0	1,72	•
RV 1500-100	100	244	144		2590	3224	284,0	1,95	•
RV 1500-125	125	294	169		2613	3262	350,0	2,24	•

Forma de pedido: Código
How to order: Code

CILINDRO RV 2400 GAS SPRING RV 2400



SW

Seguridad activa
Active safety



OSAS



USAS



OPAS

* F_{1i} =

Fuerza final isotérmica
a 100% Cu
Isothermal end force
at 100% Cu

** F_{1p} =

Fuerza final politrópica
a 100% Cu
Polytropic end force
at 100% Cu

OSAS + OSM = OVER STROKE
= ACTIVE SAVETY + OVER
STROKE MARKER

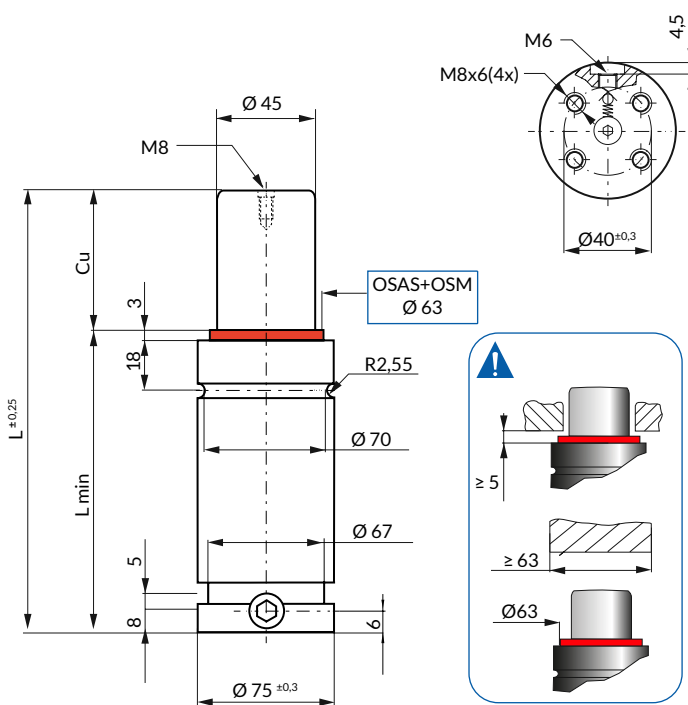

Recomendación de montaje / Assembly recommendation

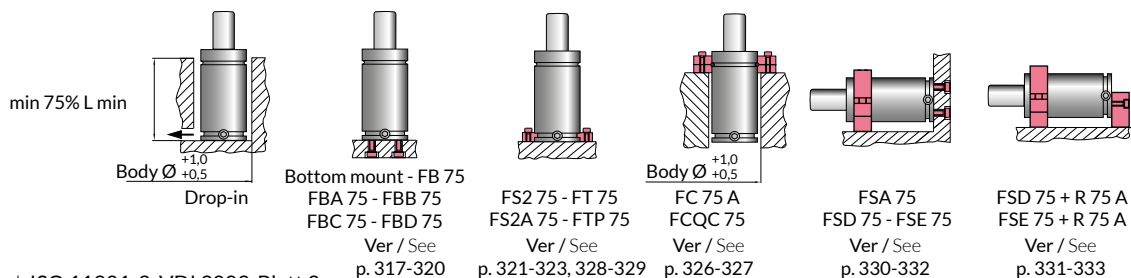

Norma / Standard: ISO 11901-3, VDI 3003-Blatt 3

		ΔP	P max	P min	S	SPM	Velocidad Max.	Kit de mantenimiento
N ₂	°C 0 - 80	± 0,33 % / °C	150 bar	20 bar	15,90 cm ²	~20 -100 (at 20°)	Max Speed 1,8 m/s	Maintenance kit 39BMRV02400D

Código Code	Cu	L	L min	F0 Fuerza inicial Initial force	F _{1i} Fuerza final* End force*	F _{1p} Fuerza final* End force*	V0		
	mm	mm	mm	daN	mm	~Kg	cm ³	~Kg	2014/68/EU
RV 2400-010	10	65	55		3264	3786	69,0	1,25	•
RV 2400-013	13	71	58		3392	3984	81,0	1,30	•
RV 2400-016	16	77	61		3493	4142	93,0	1,35	•
RV 2400-019	19	83	64	2385	3574	4271	105,0	1,40	•
RV 2400-025	25	95	70	± 5%	3698	4468	129,0	1,50	•
RV 2400-032	32	109	77		3800	4632	157,0	1,61	•
RV 2400-038	38	121	83	150bar	3864	4737	181,0	1,70	•
RV 2400-050	50	145	95		3956	4887	230,0	1,89	•
RV 2400-063	63	171	108	+20°C	4022	4996	282,0	2,10	•
RV 2400-075	75	195	120		4066	5068	330,0	2,29	•
RV 2400-080	80	205	125		4081	5093	350,0	2,37	•
RV 2400-100	100	245	145		4127	5169	431,0	2,68	•
RV 2400-125	125	295	170		4166	5234	532,0	3,07	•

Forma de pedido: Código
How to order: Code

CILINDRO RV 4200 GAS SPRING RV 4200



SW

Seguridad activa
Active safety



OSAS



USAS



OPAS

* F_{1i} =

Fuerza final isotérmica
a 100% Cu
Isothermal end force
at 100% Cu

** F_{1p} =

Fuerza final politrópica
a 100% Cu
Polytropic end force
at 100% Cu

OSAS + OSM = OVER STROKE ACTIVE SAVETY + OVER STROKE MARKER

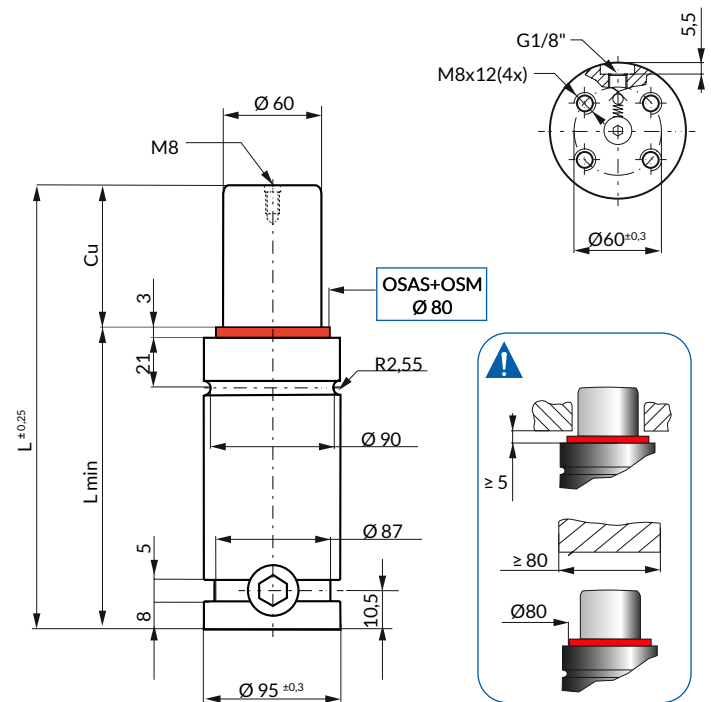

Recomendación de montaje / Assembly recommendation

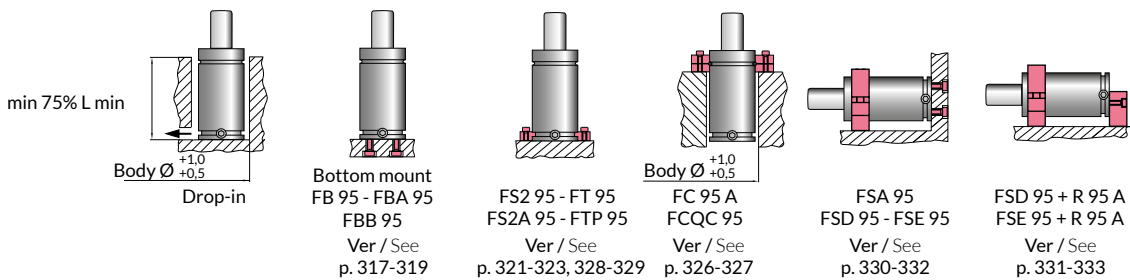

Norma / Standard: ISO 11901-3, VDI 3003-Blatt 3

		ΔP	P max	P min	S	SPM	Velocidad Max.	Kit de mantenimiento
N ₂	°C 0 - 80	± 0,33 % / °C	150 bar	20 bar	28,27 cm ²	~20 - 100 (at 20°)	Max Speed 1,8 m/s	Maintenance kit 39BMRV04200C

Código Code	Cu	L	L min	F0 Fuerza inicial Initial force	F _{1i} Fuerza final* End force*	F _{1p} Fuerza final* End force*	V0		
	mm	mm	mm	daN	mm	~Kg	cm ³	~Kg	2014/68/EU
RV 4200-016	16	90	74	4240 ± 5%	6080	7162	173,0	2,76	•
RV 4200-019	19	96	77		6246	7421	193,0	2,84	•
RV 4200-025	25	108	83		6506	7834	234,0	2,99	•
RV 4200-032	32	122	90	150bar	6729	8194	281,0	3,16	•
RV 4200-038	38	134	96		6876	8432	322,0	3,31	•
RV 4200-050	50	158	108		7091	8783	403,0	3,61	•
RV 4200-063	63	184	121	+20°C	7251	9048	491,0	3,94	•
RV 4200-075	75	208	133		7359	9227	572,0	4,24	•
RV 4200-080	80	218	138		7396	9288	606,0	4,36	•
RV 4200-100	100	258	158		7512	9483	741,0	4,86	•
RV 4200-125	125	308	183		7612	9651	910,0	5,48	•

Forma de pedido: Codigo
How to order: Code



CILINDRO RV 6600 GAS SPRING RV 6600



SW

Seguridad activa
Active safety



OSAS



USAS



OPAS

* F_{1i} =

Fuerza final isotérmica
a 100% Cu
Isothermal end force
at 100% Cu

** F_{1p} =

Fuerza final politrópica
a 100% Cu
Polytropic end force
at 100% Cu

OSAS + OSM = OVER STROKE
ACTIVE SAVETY + OVER
STROKE MARKER

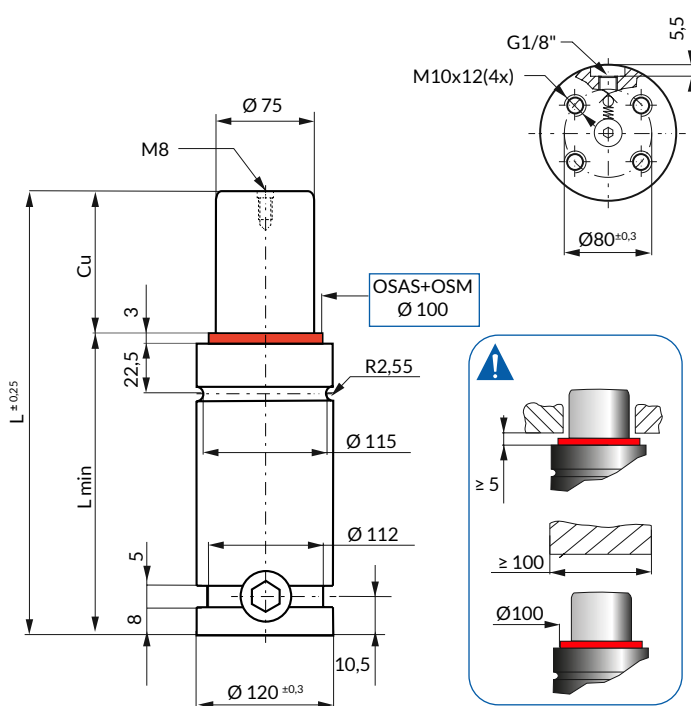

Recomendación de montaje / Assembly recommendation

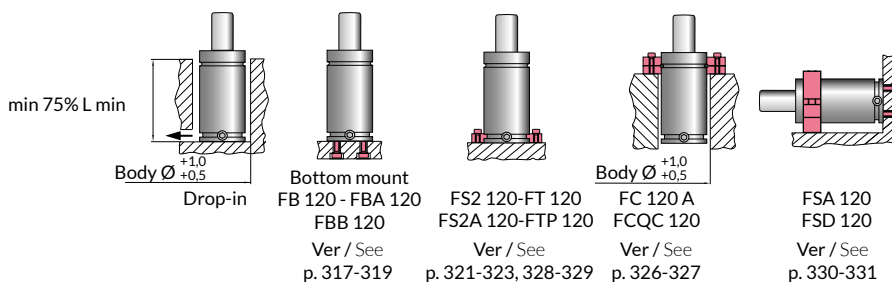

Norma / Standard: ISO 11901-3, VDI 3003-Blatt 3

		ΔP	P max	P min	S	SPM	Velocidad Máx.	Kit de mantenimiento
N ₂	°C 0 - 80	± 0,33 % / °C	150 bar	20 bar	44,18 cm ²	~20 - 100 (at 20°)	Max Speed 1,8 m/s	Maintenance kit 39BMRV06600C

Código Code	Cu	L	L min	FO Fuerza inicial Initial force	F _{1i} Fuerza final* End force*	F _{1p} Fuerza final* End force*	V0		PED 2014/68/EU
	mm	mm	mm	daN	mm	~Kg	cm ³		
RV 6600-016	16	100	84	6630 ± 5%	9125	10607	300,0	5,12	•
RV 6600-019	19	106	87		9376	10995	332,0	5,23	•
RV 6600-025	25	118	93		9779	11628	396,0	5,47	•
RV 6600-032	32	132	100	150bar	10136	12195	471,0	5,75	•
RV 6600-038	38	144	106		10375	12578	535,0	5,99	•
RV 6600-050	50	168	118		10733	13157	663,0	6,47	•
RV 6600-063	63	194	131	+20°C	11006	13604	801,0	6,99	•
RV 6600-075	75	218	143		11193	13911	930,0	7,47	•
RV 6600-080	80	228	148		11258	14018	983,0	7,67	•
RV 6600-100	100	268	168		11463	14359	1197,0	8,46	•
RV 6600-125	125	318	193		11642	14656	1464,0	9,46	•

Forma de pedido: Código
How to order: Code

CILINDRO RV 9500 GAS SPRING RV 9500



SW

Seguridad activa
Active safety



OSAS



USAS



OPAS

*F_{1i}=

Fuerza final isotérmica
a 100% Cu
Isothermal end force
at 100% Cu

**F_{1p}=

Fuerza final politrópica
a 100% Cu
Polytrophic end force
at 100% Cu

OSAS + OSM = OVER STROKE ACTIVE SAVETY + OVER STROKE MARKER

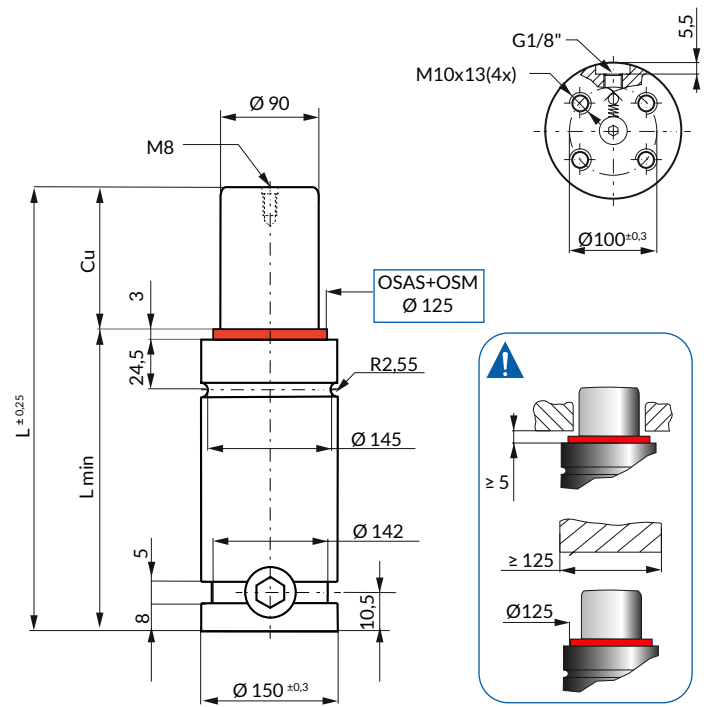

Recomendación de montaje / Assembly recommendation

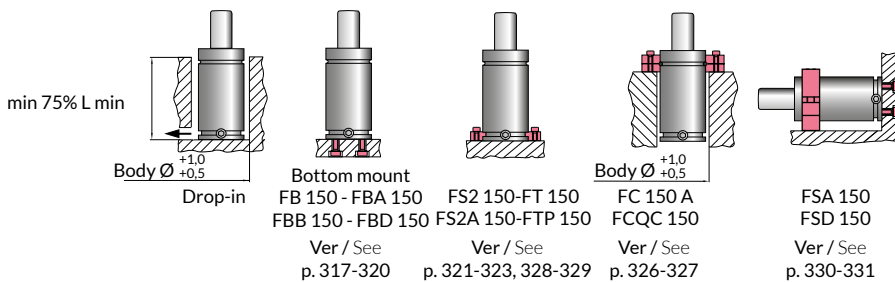

Norma / Standard: ISO 11901-3, VDI 3003-Blatt 3

		ΔP	P max	P min	S	SPM	Velocidad Máx.	Kit de mantenimiento
N ₂	°C 0 - 80	± 0,33 % / °C	150 bar	20 bar	63,62 cm ²	~20 - 80 (at 20°)	Max Speed 1,8 m/s	Maintenance kit 39BMRV09500C

Código Code	Cu	L	L min	F0	F _{1i}	F _{1p}	V0		PED 2014/68/EU	
	mm	mm	mm	Fuerza inicial Initial force	Fuerza final* End force*	Fuerza final* End force*				daN
RV 9500-019	19	116	97	9540 ± 5% 150bar +20°C	13101	15214	517,0	9,56	•	
RV 9500-025	25	128	103		13637	16044	614,0	9,93	•	
RV 9500-032	32	142	110		14112	16792	727,0	10,37	•	
RV 9500-038	38	154	116		14432	17299	823,0	10,74	•	
RV 9500-050	50	178	128		14914	18070	1017,0	11,49	•	
RV 9500-063	63	204	141		15283	18666	1226,0	12,30	•	
RV 9500-075	75	228	153		15536	19078	1420,0	13,05	•	
RV 9500-080	80	238	158		15625	19222	1500,0	13,37	•	
RV 9500-100	100	278	178		15905	19681	1823,0	14,61	•	
RV 9500-125	125	328	203		16148	20082	2226,0	16,18	•	

Forma de pedido: Código
How to order: Code



CILINDRO RV 12000 GAS SPRING RV 12000



SW

Seguridad activa
Active safety



OSAS



USAS



OPAS

* F_{1i} =

Fuerza final isotérmica
a 100% Cu
Isothermal end force
at 100% Cu

** F_{1p} =

Fuerza final politrópica
a 100% Cu
Polytropic end force
at 100% Cu

OSAS + OSM = OVER STROKE ACTIVE SAVETY + OVER STROKE MARKER

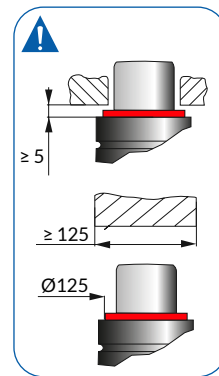
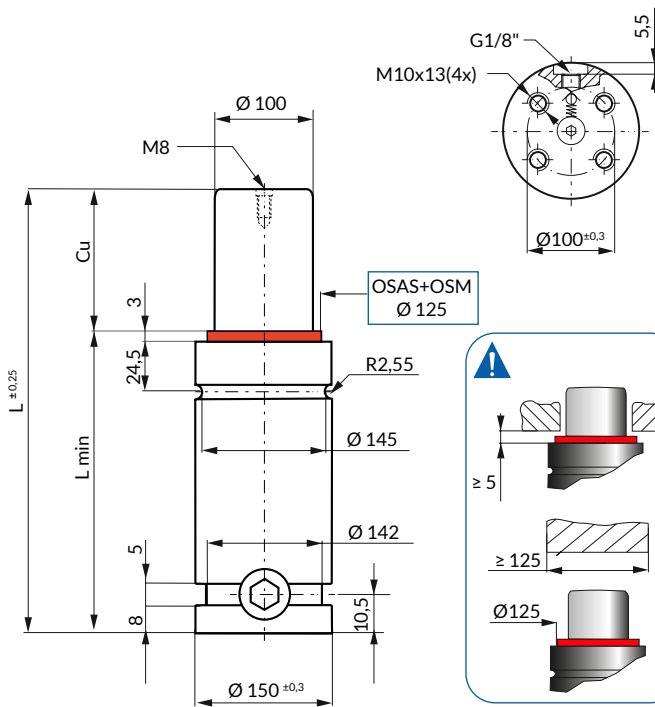

Recomendación de montaje / Assembly recommendation

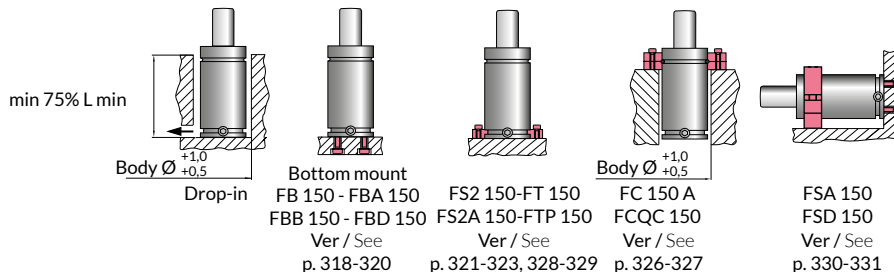

		ΔP	P max	P min	S	SPM	Velocidad Máx.	Kit de mantenimiento
N ₂	°C 0 - 80	± 0,33 % / °C	150 bar	20 bar	78,54 cm ²	~20 - 80 (at 20°)	Max Speed 1,8 m/s	Maintenance kit 39BMRV12000A

Código Code	Cu	L	L min	F0	F _{1i}	F _{1p}	V0		
	mm	mm	mm	Fuerza inicial Initial force daN	Fuerza final* End force* mm	Fuerza final* End force* ~Kg			
RV 12000-019	19	116	97		16891	19896	571,0	9,34	•
RV 12000-025	25	128	103		17735	21225	675,0	9,73	•
RV 12000-032	32	142	110	11780	18503	22454	796,0	10,18	•
RV 12000-038	38	154	116	± 5%	19030	23307	900,0	10,57	•
RV 12000-050	50	178	128		19837	24629	1108,0	11,35	•
RV 12000-063	63	204	141	150bar	20469	25676	1332,0	12,20	•
RV 12000-075	75	228	153		20909	26412	1540,0	12,97	•
RV 12000-080	80	238	158	+20°C	21063	26671	1626,0	13,30	•
RV 12000-100	100	278	178		21559	27507	1972,0	14,60	•
RV 12000-125	125	328	203		21995	28249	2405,0	16,22	•

Forma de pedido: Código
How to order: Code

CILINDRO RV 20000 GAS SPRING RV 20000



SW

Seguridad activa
Active safety



OSAS



USAS



OPAS

* F_{1i} =

Fuerza final isotérmica
a 100% Cu
Isothermal end force
at 100% Cu

** F_{1p} =

Fuerza final politrópica
a 100% Cu
Polytropic end force
at 100% Cu

OSAS + OSM = OVER STROKE ACTIVE SAVETY + OVER STROKE MARKER

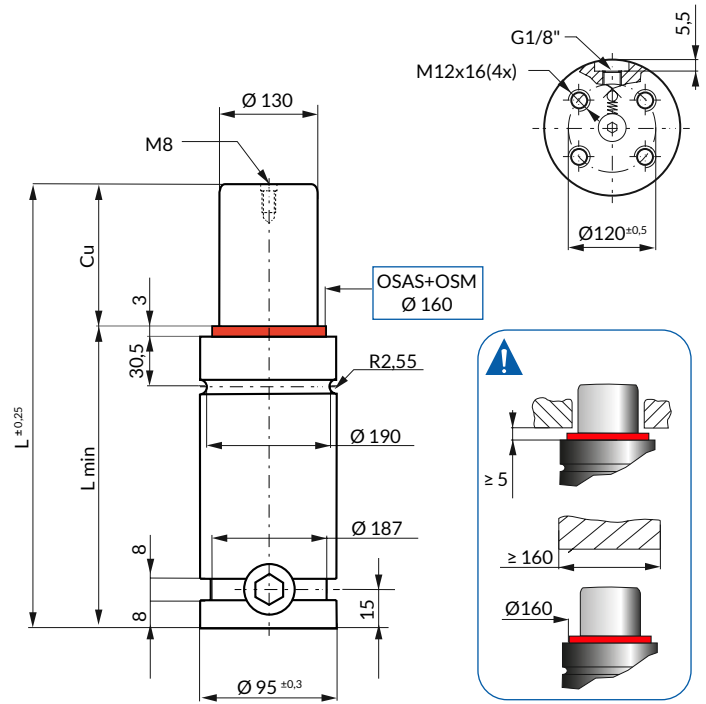

Recomendación de montaje / Assembly recommendation

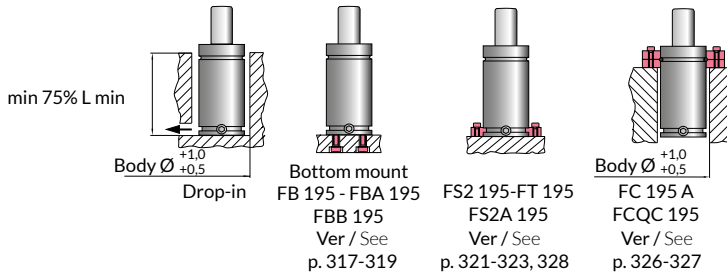

		ΔP	P max	P min	S	SPM	Velocidad Máx.	Kit de mantenimiento
N ₂	°C 0 - 80	± 0,33 % / °C	150 bar	20 bar	132,73 cm ²	~20 -80 (at 20°)	Max Speed 1,8 m/s	Maintenance kit 39BMRV20000A

Código Code	Cu	L	L min	F0	F _{1i}	F _{1p}	V0		PED 2014/68/EU
	mm	mm	mm	Fuerza inicial Initial force daN	Fuerza final* End force* mm	Fuerza final* End force* ~Kg			
RV 20000-019	19	148	129		26987	31207	1118,0	21,58	•
RV 20000-025	25	160	135		28383	33368	1288,0	22,29	•
RV 20000-032	32	174	142	19910	29722	35474	1486,0	23,12	•
RV 20000-038	38	186	148	± 5%	30681	37002	1656,0	23,84	•
RV 20000-050	50	210	160		32220	39486	1995,0	25,26	•
RV 20000-063	63	236	173	150bar	33486	41560	2362,0	26,80	•
RV 20000-075	75	260	185		34403	43077	2702,0	28,22	•
RV 20000-080	80	270	190	+20°C	34731	43624	2843,0	28,81	•
RV 20000-100	100	310	210		35811	45434	3409,0	31,19	•
RV 20000-125	125	360	235		36794	47097	4116,0	34,16	•

Forma de pedido: Código
How to order: Code

CILINDRO SC GAS SPRING SC

STOCK

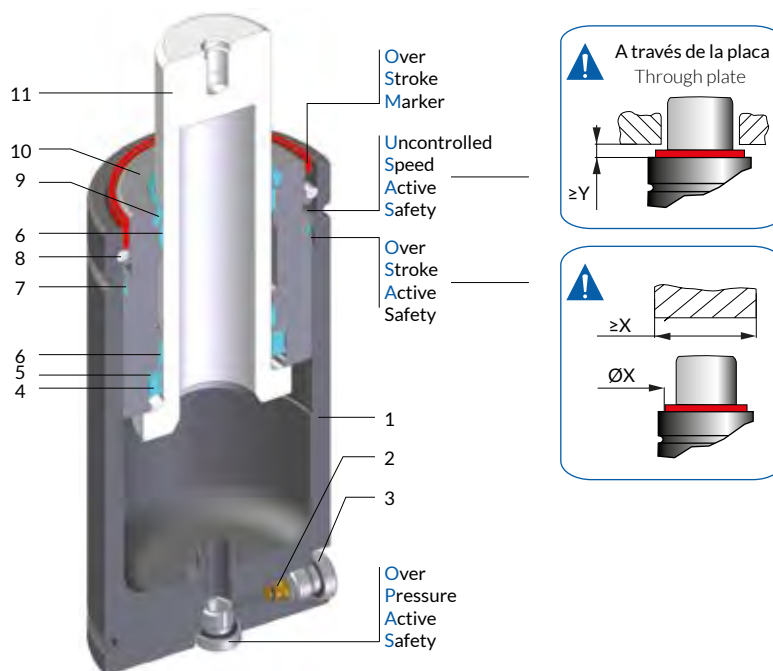

Norma / Standard: ISO, VDI

Modelo Model	Cuerpo Ø Body Ø	Carrera Cu Stroke Cu	Fuerza inicial F0 Initial force F0					
	mm	mm	daN	OSAS	USAS	OPAS	SKUDO	SW (opcional)
SC 150	32	10 - 125	170	•	•	•	-	•
SC 250	38	10 - 125	260	•	•	•	-	•
SCF 250	M38 X 1,5	10 - 125	260	•	•	•	-	•
SC 500	45	10 - 125	470	•	•	•	-	•
SC 750	50	13 - 125	740	•	•	•	-	•
SC 1500	75	13 - 125	1530	•	•	•	-	•
SC 3000	95	13 - 125	2945	•	•	•	-	•
SC 5000	120	25 - 125	4980	•	•	•	-	•
SC 7500	150	25 - 125	7540	•	•	•	-	•
SC10000	195	25 - 125	10600	•	•	•	-	•

1	Cuerpo / Body	7	Anillo dual / Dual ring seal
2	Válvula / Valve	8	Anillo de retención / Retaining ring
3	Tapón / Plug	9	Rascador / Rod wiper
4	Retén / Rod seal	10	Casquillo / Bush
5	Anillo antiextrusión / Back-up ring	11	Vástago (nitruado) / Rod (nitrited super finished)
6	Anillo guía / Guide ring		

Versiones disponibles / Available versions



Código estándar / Standard code



Cilindro
GAS SPRING



Código estándar+W / Standard code+W



Cilindro
GAS SPRING



+
Rascafor secundario
Secondary wiper

Ver / See p. 338



Código estándar+N / Standard code+N



Conectable
Linkable

Ver / See p. 335



Código estándar+N-W / Standard code+N-W



Conectable
Linkable



+
Rascafor secundario
Secondary wiper

Ver / See p.
335-338



Código estándar+E / Standard code+E



Easy
Manifold

Ver / See p. 336



Código estándar+E-W / Standard code+N-W



Easy
Manifold



+
Rascafor secundario
Secondary wiper

Ver / See p.
336-338

CILINDRO SC 150 GAS SPRING SC 150



Seguridad activa
Active safety



* F₁ = Fuerza final isotérmica a 100% Cu
Isothermal end force at 100% Cu

** F_{1p} = Fuerza final politrópica a 100% Cu
Polytropic end force at 100% Cu

OSAS + OSM OVER STROKE ACTIVE SAVETY + OVER STROKE MARKER

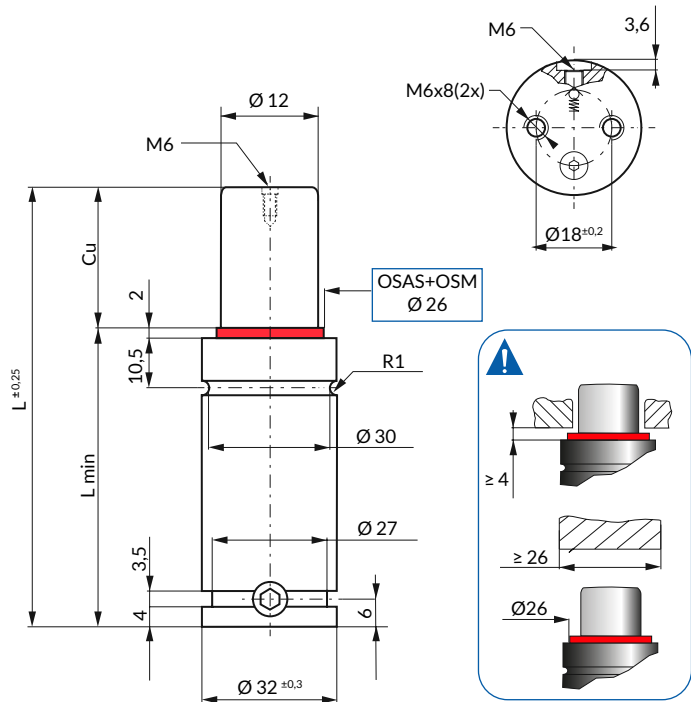

Recomendación de montaje / Assembly recommendation

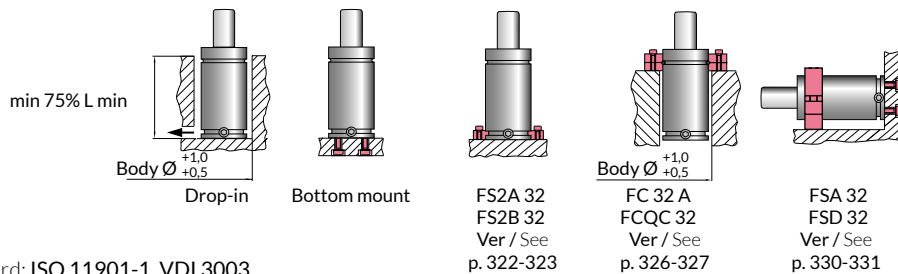

Norma / Standard: ISO 11901-1, VDI 3003

		ΔP	P max	P min	S	SPM	Velocidad Máx.	Kit de mantenimiento
N ₂	°C 0 - 80	± 0,33 % / °C	150 bar	20 bar	1,13 cm ²	~80 - 100 (at 20°)	Max Speed 1,8 m/s	Maintenance kit 39BMSC00150E

Código Code	Cu	L	L min	F0 Fuerza inicial Initial force	F ₁ Fuerza final* End force*	F _{1p} Fuerza final* End force*	V0		
	mm	mm	mm	daN	mm	~Kg	cm ³		
SC 150 - 010	10	70	60	170 ± 5%	191	207	12,0	0,28	•
SC 150 - 013	12,7	75,4	62,7		194	212	14,0	0,29	•
SC 150 - 016	16	82	66		197	216	16,0	0,30	•
SC 150 - 025	25	100	75		202	224	21,0	0,33	•
SC 150 - 038	38	126	88		207	231	28,0	0,36	•
SC 150 - 050	50	150	100		209	235	35,0	0,40	•
SC 150 - 063	63,5	177	13,		211	238	43,0	0,44	•
SC 150 - 080	80	210	130		213	240	52,0	0,49	•
SC 150 - 100	100	250	150		214	242	63,0	0,55	•
SC 150 - 125	125	300 "	175"		216	244	78,0	0,64	•

Forma de pedido: Código
How to order: Code

CILINDRO SC 250 GAS SPRING SC 250



SW

Seguridad activa
Active safety



OSAS



USAS



OPAS

* F_{1i} =

Fuerza final isotérmica
a 100% Cu
Isothermal end force
at 100% Cu

** F_{1p} =

Fuerza final politrópica
a 100% Cu
Polytrophic end force
at 100% Cu

OSAS + OSM OVER STROKE
= ACTIVE SAFETY + OVER
STROKE MARKER



Recomendación de montaje / Assembly recommendation

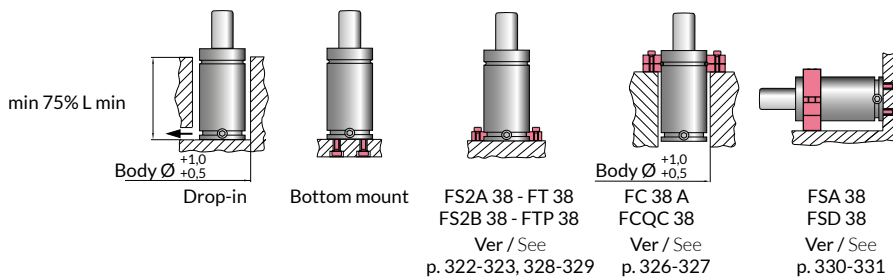
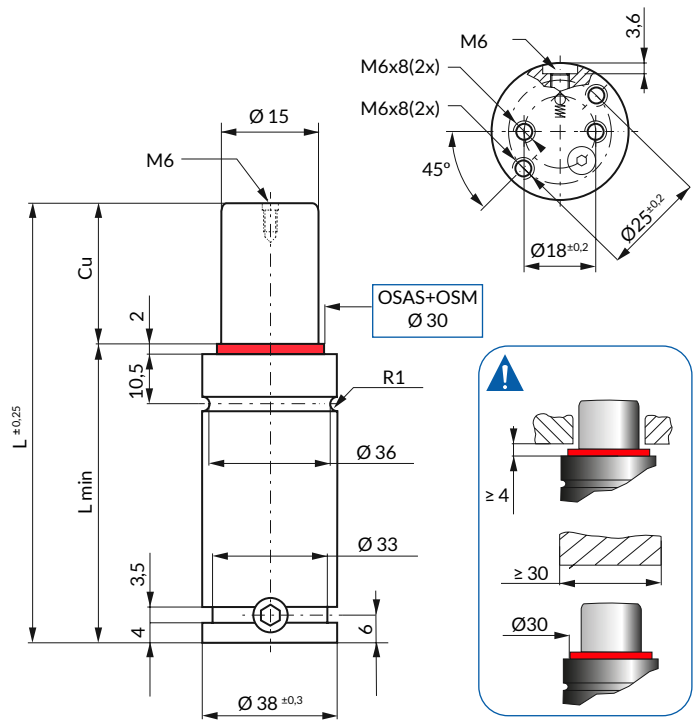

Norma / Standard: ISO 11901-1, VDI 3003

		ΔP	P max	P min	S	SPM	Velocidad Máx.	Kit de mantenimiento
N ₂	°C 0 - 80	±0,33 % / °C	150 bar	20 bar	1,77 cm ²	~80 -100 (at 20°)	Max Speed 1,8 m/s	Maintenance kit 39BMSC00250E

Código Code	Cu	L	L min	F0	F _{1i}	F _{1p}	V0		PED 2014/68/EU	
	mm	mm	mm	Fuerza inicial Initial force	Fuerza final* End force*	Fuerza final* End force*				daN
SC 250 - 010	10	70	60	260	± 5%	303	332	16,0	0,40	•
SC 250 - 013	12,7	75,4	62,7			309	340	19,0	0,41	•
SC 250 - 016	16	82	66			315	348	21,0	0,43	•
SC 250 - 016	19	88	69	150bar	+20°C	319	354	23,0	0,45	•
SC 250 - 025	25	100	75			325	364	28,0	0,48	•
SC 250 - 038	38	126	88			334	377	38,0	0,54	•
SC 250 - 050	50	150	100	+20°C		339	385	47,0	0,60	•
SC 250 - 063	63,5	177	13,			343	391	58,0	0,66	•
SC 250 - 080	80	210	130			346	395	70,0	0,74	•
SC 250 - 100	100	250	150			349	399	85,0	0,81	•
SC 250 - 125	125	300 "	175"			351	403	105,0	0,98	•

Forma de pedido: Código
How to order: Code

CILINDRO SC 500 GAS SPRING SC 500

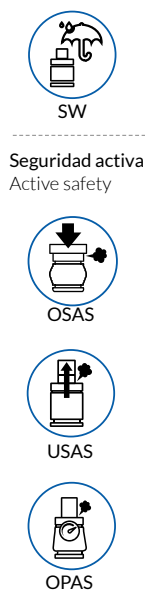

* F_{1_i} = Fuerza final isotérmica a 100% Cu
Isothermal end force at 100% Cu

** F_{1_p} = Fuerza final politrópica a 100% Cu
Polytropic end force at 100% Cu

OSAS + OSM = OVER STROKE ACTIVE SAVETY + OVER STROKE MARKER

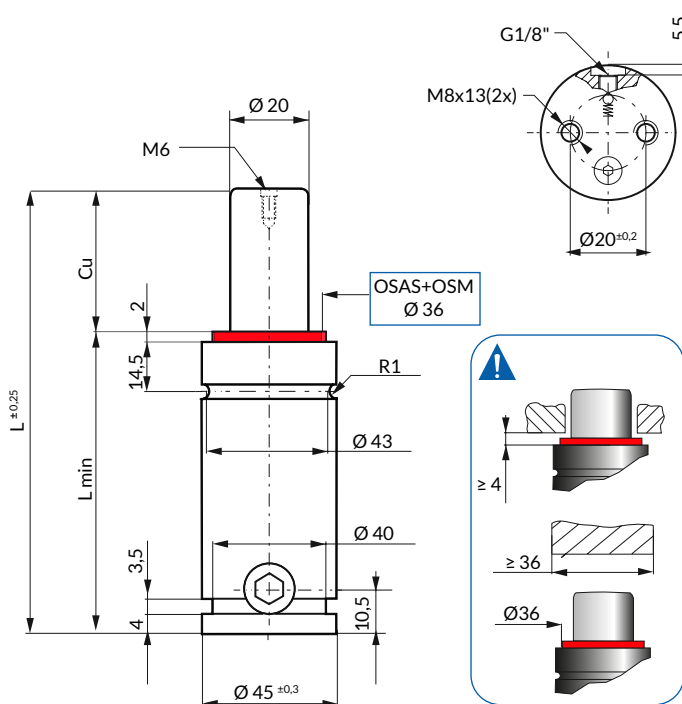

Recomendación de montaje / Assembly recommendation

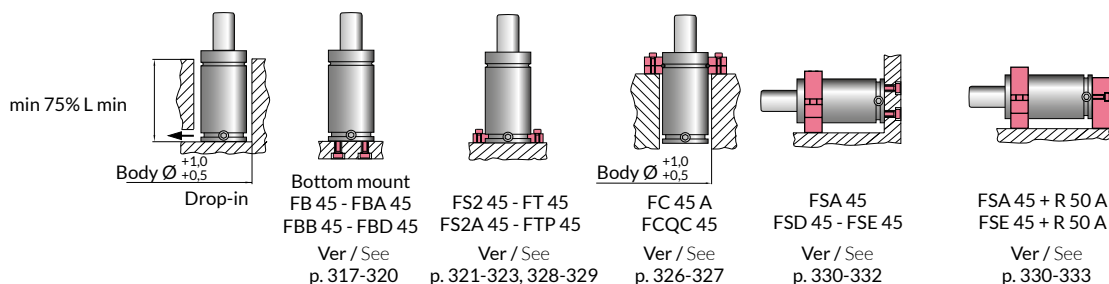

Norma / Standard: ISO 11901-1, VDI 3003

		ΔP	P max	P min	S	SPM	Velocidad Máx.	Kit de mantenimiento
N ₂	°C 0 - 80	± 0,33 % / °C	150 bar	20 bar	3,14 cm ²	~40 - 80 (at 20°)	Max Speed 1,8 m/s	Maintenance kit 39BMSC00250E

Código Code	Cu	L	L min	F0	F _{1_i}	F _{1_p}	V0			
	mm	mm	mm	Fuerza inicial Initial force	Fuerza final* End force*	Fuerza final* End force*				daN
SC 500 - 010	10	105	95	470	595	673	18,0	0,90	•	
SC 500 - 013	12,7	110,4	97,7		611	696	20,0	1,00	•	
SC 500 - 025	25	135	110		652	759	33,0	1,09	•	
SC 500 - 038	38	161	123	± 5%	673	792	46,0	1,20	•	
SC 500 - 050	50	185	135		685	810	58,0	1,29	•	
SC 500 - 063	63,5	212	148,5		693	823	72,0	1,38	•	
SC 500 - 080	80	245	165	150bar	700	834	89,0	1,50	•	
SC 500 - 100	100	285	185		706	843	109,0	1,64	•	
SC 500 - 125	125	335	210		710	850	135,0	1,85	•	
SC 500 - 160	160	405	245	+20°C	715	857	170,0	2,10	•	
SC 500 - 200	200	485	285		728	878	205,0	2,36	•	

Forma de pedido: Código
How to order: Code

CILINDRO SC 750 GAS SPRING SC 750



SW

Seguridad activa
Active safety



OSAS



USAS



OPAS

* F_{1i} =

Fuerza final isotérmica
a 100% Cu
Isothermal end force
at 100% Cu

** F_{1p} =

Fuerza final politrópica
a 100% Cu
Polytrophic end force
at 100% Cu

OSAS + OSM = OVER STROKE ACTIVE SAVETY + OVER STROKE MARKER



Recomendación de montaje / Assembly recommendation

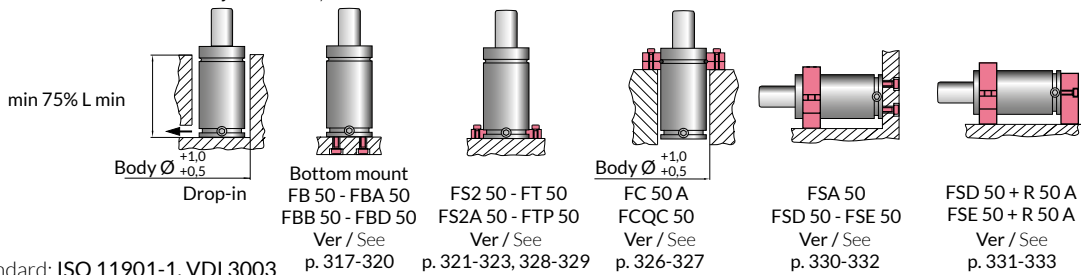

Norma / Standard: ISO 11901-1, VDI 3003

		ΔP	P max	P min	S	SPM	Velocidad Máx.	Kit de mantenimiento
N ₂	°C 0 - 80	± 0,33 % / °C	150 bar	20 bar	4,91 cm ²	~15 - 50 (at 20°)	Max Speed 1,8 m/s	Maintenance kit 39BMSC00750D

Código Code	Cu	L	L min	F0	F _{1i}	F _{1p}	V0		PED 2014/68/EU
	mm	mm	mm	Fuerza inicial Initial force	Fuerza final* End force*	Fuerza final* End force*			
SC 750 - 013	12,7	120,4	107,7		902	1009	40,0	1,24	•
SC 750 - 025	25	145	120		977	1122	58,0	1,34	•
SC 750 - 038	38	171	133		1023	1192	77,0	1,45	•
SC 750 - 050	50	195	145		1050	1235	95,0	1,54	•
SC 750 - 063	63,5	222	158,5		1072	1269	115,0	1,65	•
SC 750 - 075	75	245	170		1086	1291	132,0	1,75	•
SC 750 - 080	80	255	175		1091	1299	140,0	1,79	•
SC 750 - 088	88	270	182	740	1101	1314	150,0	1,85	•
SC 750 - 100	100	295	195	± 5%	1107	1324	169,0	1,96	•
SC 750 - 113	113	320	207		1117	1340	188,0	2,06	•
SC 750 - 125	125	345	220	150bar	1121	1346	206,0	2,16	•
SC 750 - 138	138	370	232		1131	1363	224,0	2,27	•
SC 750 - 150	150	395	245	+20°C	1140	1378	239,0	2,39	•
SC 750 - 160	160	415	255		1149	1391	252,0	2,49	•
SC 750 - 175	175	445	270		1160	1408	271,0	2,64	•
SC 750 - 200	200	495	295		1175	1434	302,0	2,89	•
SC 750 - 225	225	545	320		1188	1455	334,0	3,13	•
SC 750 - 250	250	595	345		1199	1472	365,0	3,32	•
SC 750 - 275	275	645	370		1208	1488	396,0	3,63	•
SC 750 - 300	300	695	395		1216	1501	428,0	3,88	•

Forma de pedido: Código
How to order: Code



CILINDRO SC 1500 GAS SPRING SC 1500

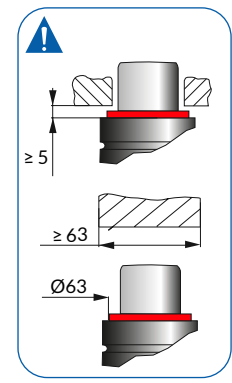
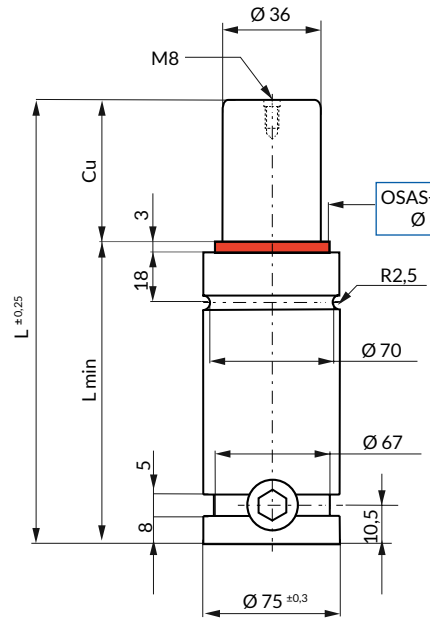
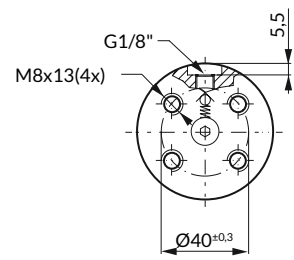

SW
Seguridad activa
Active safety



* F_{1i} = Fuerza final isotérmica a 100% Cu
Isothermal end force at 100% Cu

** F_{1p} = Fuerza final politrópica a 100% Cu
Polytropic end force at 100% Cu

OSAS + OSM = OVER STROKE ACTIVE SAVETY + OVER STROKE MARKER



Recomendación de montaje / Assembly recommendation

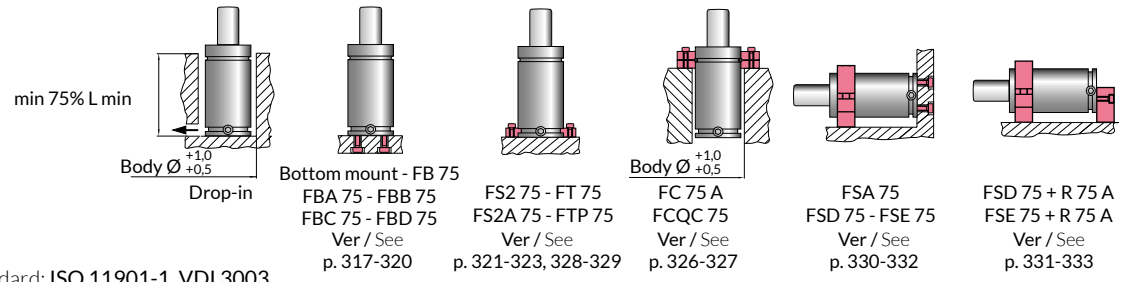

Norma / Standard: ISO 11901-1, VDI 3003

N ₂	°C 0 - 80	ΔP ± 0,33 % / °C	P max 150 bar	P min 20 bar	S 10,18 cm ²	SPM ~15 - 50 (at 20°)	Velocidad Máx. Max Speed 1,8 m/s	Kit de mantenimiento Maintenance kit 39BMSC01500D Cu 13/80 39BMSC01500DH Cu 88/300
----------------	-----------	-----------------------------	------------------	-----------------	----------------------------	--------------------------	--	---

Código Code	Cu	L	L min	F0 Fuerza inicial Initial force	F _{1i} Fuerza final* End force*	F _{1p} Fuerza final* End force*	V0		 2014/68/EU
	mm	mm	mm	daN	mm	~Kg	cm ³		
SC 1500 - 013	13	135	122		1819	2016	97,0	3,26	•
SC 1500 - 025	25	160	135		1925	2174	144,0	3,47	•
SC 1500 - 038	38	186	148		2000	2287	191,0	3,67	•
SC 1500 - 050	50	210	160		2045	2355	234,0	3,85	•
SC 1500 - 063	63,5	237	173,5		2080	2409	283,0	4,05	•
SC 1500 - 075	75	260	185		2102	2443	324,0	4,23	•
SC 1500 - 080	80	270	190		2110	2455	342,0	4,30	•
SC 1500 - 088	88	285	197	1530	2130	2486	367,0	4,42	•
SC 1500 - 100	100	310	210	± 5%	2136	2495	414,0	4,60	•
SC 1500 - 113	113	335	222		2151	2520	459,0	4,78	•
SC 1500 - 125	125	360	235	150bar	2158	2529	505,0	4,97	•
SC 1500 - 138	138	385	247		2169	2548	550,0	5,16	•
SC 1500 - 150	150	410	260	+20°C	2173	2554	595,0	5,35	•
SC 1500 - 160	160	430	270		2178	2562	631,0	5,50	•
SC 1500 - 175	175	460	285		2185	2572	685,0	5,73	•
SC 1500 - 200	200	510	310		2198	2592	772,0	6,13	•
SC 1500 - 225	225	560	335		2219	2625	850,0	6,60	•
SC 1500 - 250	250	610	360		2236	2652	928,0	7,08	•
SC 1500 - 275	275	660	385		2251	2676	1006,0	7,55	•
SC 1500 - 300	300	710	410		2264	2696	1084,0	8,02	•

Forma de pedido: Código
How to order: Code

CILINDRO SC 3000 GAS SPRING SC 3000



SW

Seguridad activa
Active safety



OSAS



USAS



OPAS

* F_{1i} =

Fuerza final isotérmica a 100% Cu
Isothermal end force at 100% Cu

** F_{1p} =

Fuerza final politrópica a 100% Cu
Polytropic end force at 100% Cu

OSAS + OSM = OVER STROKE ACTIVE SAFETY + OVER STROKE MARKER

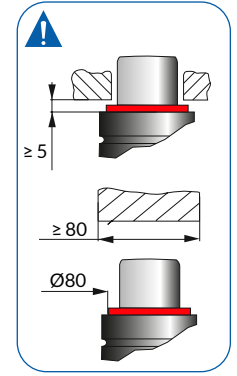
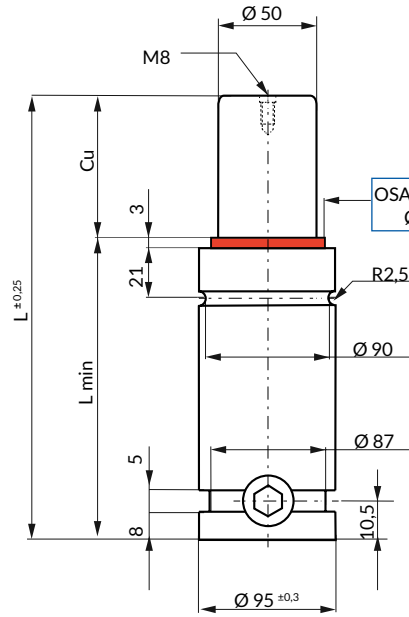
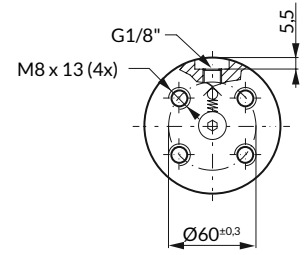

Recomendación de montaje / Assembly recommendation

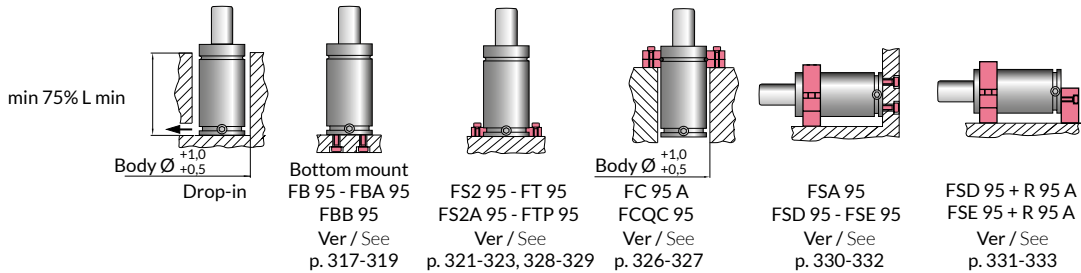

Norma / Standard: ISO 11901-1, VDI 3003

		ΔP	P max	P min	S	SPM	Velocidad Máx.	Kit de mantenimiento
N ₂	°C 0 - 80	± 0,33 % / °C	150 bar	20 bar	19,63 cm ²	~15 - 50 (at 20°)	Max Speed 1,8 m/s	Maintenance kit 39BMSC03000D Cu 13/80 39BMSC03000DH Cu 88/300

Código Code	Cu	L	L min	F ₀ Fuerza inicial Initial force	F _{1i} Fuerza final* End force*	F _{1p} Fuerza final* End force*	V ₀		
	mm	mm	mm	daN	mm	~Kg	cm ³		~Kg
SC 3000 - 013	13	145	132		3528	3917	181,0	5,57	•
SC 3000 - 025	25	170	145		3775	4286	261,0	5,90	•
SC 3000 - 038	38	196	158		3955	4559	340,0	6,21	•
SC 3000 - 050	50	220	170		4067	4732	413,0	6,50	•
SC 3000 - 063	63,5	247	183,5		4158	4873	496,0	6,83	•
SC 3000 - 075	75	270	195		4216	4964	566,0	7,10	•
SC 3000 - 080	80	280	200		4238	4997	596,0	7,22	•
SC 3000 - 088	88	295	207	2945	4277	5059	642,0	7,41	•
SC 3000 - 100	100	320	220	± 5%	4307	5105	718,0	7,67	•
SC 3000 - 113	113	345	232		4348	5171	795,0	7,97	•
SC 3000 - 125	125	370	245	150bar	4367	5201	871,0	8,27	•
SC 3000 - 138	138	395	257		4398	5250	947,0	8,57	•
SC 3000 - 150	150	420	270	+20°C	4411	5270	1023,0	8,87	•
SC 3000 - 160	160	440	280		4425	5292	1085,0	9,11	•
SC 3000 - 175	175	470	295		4443	5322	1176,0	9,47	•
SC 3000 - 200	200	520	320		4469	5362	1329,0	10,08	•
SC 3000 - 225	225	570	345		4489	5395	1481,0	10,68	•
SC 3000 - 250	250	620	370		4506	5422	1634,0	11,28	•
SC 3000 - 275	275	670	395		4520	5444	1786,0	11,88	•
SC 3000 - 300	300	720	420		4532	5463	1939,0	12,49	•

Forma de pedido: Código
How to order: Code

CILINDRO SC 5000 GAS SPRING SC 5000

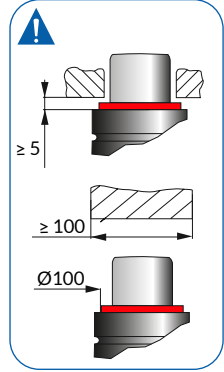
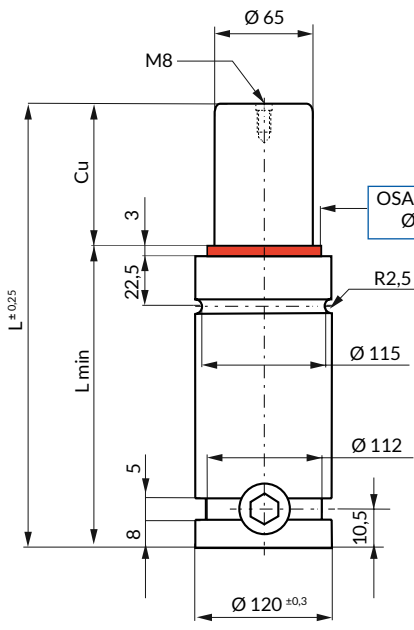
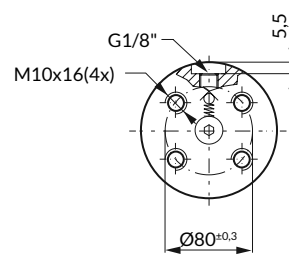

- SW
- Seguridad activa / Active safety
- OSAS
- USAS
- OPAS

* F₁ = Fuerza final isotérmica a 100% Cu
Isothermal end force at 100% Cu

** F_{1p} = Fuerza final politrópica a 100% Cu
Polytrophic end force at 100% Cu

OSAS + OSM = OVER STROKE ACTIVE SAVETY + OVER STROKE MARKER

easy
MANIFOLD

Recomendación de montaje / Assembly recommendation

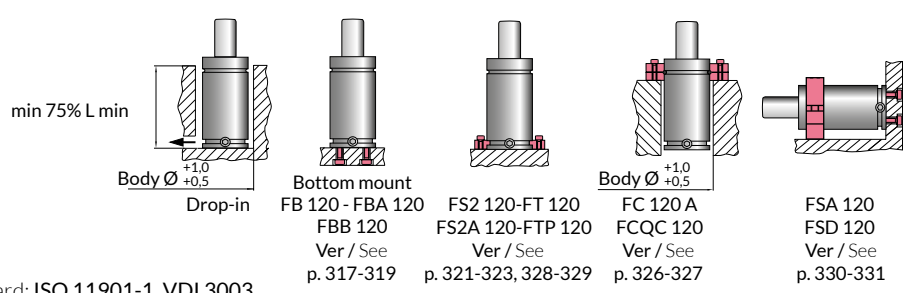

Norma / Standard: ISO 11901-1, VDI 3003

N ₂	°C 0 - 80	ΔP ±0,33 % / °C	P max 150 bar	P min 20 bar	S 33,18 cm ²	SPM ~15 - 50 (at 20°)	Velocidad Máx. Max Speed 1,8 m/s	Kit de mantenimiento Maintenance kit 39BMSC05000D Cu 25/80 39BMSC05000DH Cu 88/300
----------------	-----------	----------------------------	------------------	-----------------	----------------------------	--------------------------	--	---

Código Code	Cu	L	L min	F0 Fuerza inicial Initial force	F ₁ Fuerza final* End force*	F _{1p} Fuerza final* End force*	V0		PED 2014/68/EU
	mm	mm	mm	daN	mm	~Kg	cm ³		
SC 5000 - 025	25	190	165		6316	7148	457,0	10,94	•
SC 5000 - 038	38	216	178		6652	7657	583,0	11,46	•
SC 5000 - 050	50	240	190		6872	7994	699,0	11,94	•
SC 5000 - 063,5	63,5	267	203,5		7077	8313	823,0	12,56	•
SC 5000 - 075	75	290	215		7176	8467	941,0	12,94	•
SC 5000 - 080	80	300	220		7221	8537	989,0	13,15	•
SC 5000 - 088	88	315	227		7300	8662	1061,0	13,39	•
SC 5000 - 100	100	340	240	4980	7367	8768	1182,0	13,89	•
SC 5000 - 113	113	365	252	± 5%	7454	8906	1303,0	14,40	•
SC 5000 - 125	125	390	265		7499	8977	1424,0	14,90	•
SC 5000 - 138	138	415	277	150bar	7564	9081	1545,0	15,40	•
SC 5000 - 150	150	440	290		7595	9130	1665,0	15,90	•
SC 5000 - 160	160	460	300	+20°C	7627	9181	1762,0	16,30	•
SC 5000 - 175	175	490	315		7668	9247	1907,0	16,90	•
SC 5000 - 200	200	540	340		7726	9340	2148,0	17,91	•
SC 5000 - 225	225	590	365		7773	9415	2390,0	18,91	•
SC 5000 - 250	250	640	390		7811	9477	2632,0	19,91	•
SC 5000 - 275	275	690	415		7843	9529	2873,0	20,92	•
SC 5000 - 300	300	740	440		7871	9573	3115,0	21,92	•

Forma de pedido: Código
How to order: Code

CILINDRO SC 7500 GAS SPRING SC 7500



SW

Seguridad activa
Active safety



OSAS



USAS



OPAS

* $F1_i =$ Fuerza final isotérmica a 100% Cu
Isothermal end force at 100% Cu

** $F1_p =$ Fuerza final politrópica a 100% Cu
Polytropic end force at 100% Cu

OSAS + OSM = OVER STROKE ACTIVE SAVEDY + OVER STROKE MARKER



Recomendación de montaje / Assembly recommendation

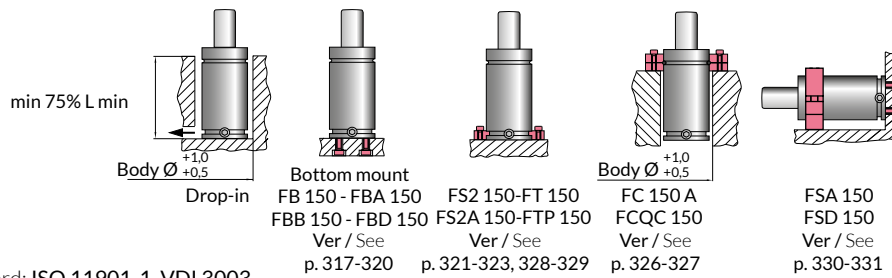

Norma / Standard: ISO 11901-1, VDI 3003

		ΔP	P max	P min	S	SPM	Velocidad Máx.	Kit de mantenimiento
N_2	$^{\circ}C$ 0 - 80	$\pm 0,33 \% / ^{\circ}C$	150 bar	20 bar	50,27 cm ²	$\sim 15 - 50$ (at 20°)	Max Speed 1,8 m/s	Maintenance kit 39BMSC07500D Cu 25/80 39BMSC075000DH Cu 88/300

Código Code	Cu	L	L min	F0	F1 _i	F1 _p	V0		PED 2014/88/EU
	mm	mm	mm	Fuerza inicial Initial force daN	Fuerza final* End force* mm	Fuerza final* End force* ~Kg			
SC 7500 - 025	25	205	180		9330	10472	767,0	18,71	•
SC 7500 - 038	38	231	193		9809	11192	963,0	19,50	•
SC 7500 - 050	50	255	205		10129	11679	1144,0	20,24	•
SC 7500 - 063	63,5	282	218,5		10400	12095	1348,0	21,06	•
SC 7500 - 075	75	305	230		10581	12375	1522,0	21,76	•
SC 7500 - 080	80	315	235		10648	12480	1597,0	22,07	•
SC 7500 - 088	88	330	242		10778	12682	1706,0	22,45	•
SC 7500 - 100	100	355	255	7540	10871	12828	1899,0	23,23	•
SC 7500 - 113	113	380	267	$\pm 5\%$	11013	13051	2083,0	23,98	•
SC 7500 - 125	125	405	280		11073	13146	2276,0	24,76	•
SC 7500 - 138	138	430	292	150bar	11182	13318	2460,0	25,51	•
SC 7500 - 150	150	455	305		11222	13382	2654,0	26,28	•
SC 7500 - 160	160	475	315	+20°C	11272	13459	2805,0	26,90	•
SC 7500 - 175	175	505	330		11337	13563	3031,0	27,81	•
SC 7500 - 200	200	555	355		11427	13707	3409,0	29,34	•
SC 7500 - 225	225	605	380		11501	13824	3786,0	30,87	•
SC 7500 - 250	250	655	405		11562	13921	4164,0	32,39	•
SC 7500 - 275	275	705	430		11613	14003	4541,0	33,92	•
SC 7500 - 300	300	755	455		11657	14073	4919,0	35,45	•

Forma de pedido: Código
How to order: Code



CILINDRO SC 10000 GAS SPRING SC 10000



Seguridad activa
Active safety



* F_{1i} = Fuerza final isotérmica a 100% Cu
Isothermal end force at 100% Cu

** F_{1p} = Fuerza final politrópica a 100% Cu
Polytrophic end force at 100% Cu

OSAS + OSM = OVER STROKE ACTIVE SAVETY + OVER STROKE MARKER

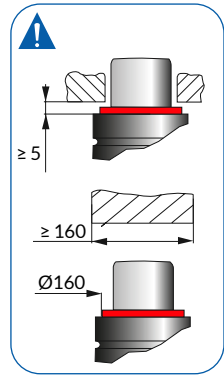
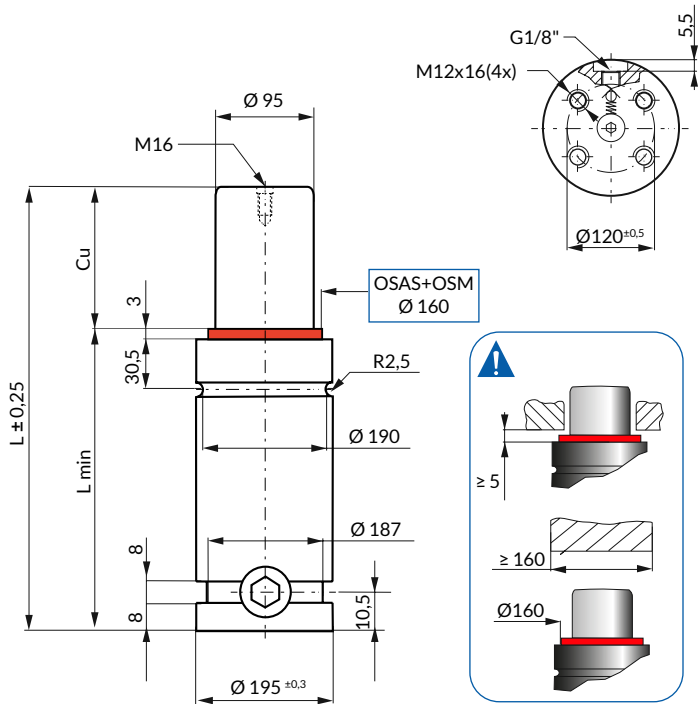

Recomendación de montaje / Assembly recommendation

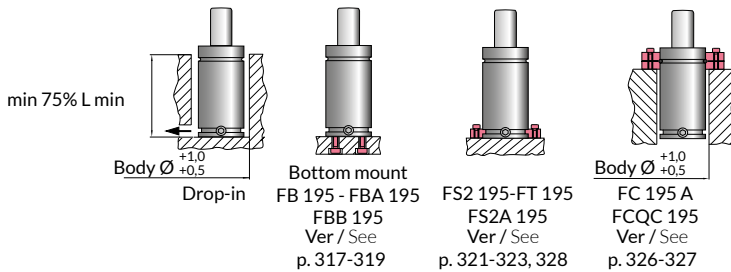

Norma / Standard: ISO 11901-1, VDI 3003

		ΔP	P max	P min	S	SPM	Velocidad Máx. Max Speed	Kit de mantenimiento Maintenance kit
N ₂	°C 0 - 80	± 0,33 % / °C	150 bar	20 bar	70,88 cm ²	~15 -50 (at 20°)	1,8 m/s	39BMSC10000D

Código Code	Cu	L	L min	F0 Fuerza inicial Initial force	F _{1i} Fuerza final* End force*	F _{1p} Fuerza final* End force*	V0		PED 2014/88/EU
	mm	mm	mm	daN	mm	~Kg	cm3		
SC 10000 - 025	25	210	185	10600	12892	14373	1186,0	33,73	•
SC 10000 - 038	38	236	198		13463	15225	1497,0	35,08	•
SC 10000 - 050	50	260	210		13838	15790	1784,0	36,32	•
SC 10000 - 063	63,5	287	223,5	± 5%	14151	16266	2108,0	37,72	•
SC 10000 - 080	80	320	240		14434	16700	2503,0	39,44	•
SC 10000 - 100	100	360	260		14686	17087	2982,0	41,51	•
SC 10000 - 125	125	410	285	150bar	14912	17438	3581,0	44,11	•
SC 10000 - 160	160	480	320		15132	17780	4419,0	47,74	•
SC 10000 - 200	200	560	360		15345	18114	5343,0	52,17	•
SC 10000 - 250	250	660	410	+20°C	15696	18665	6348,0	58,87	•
SC 10000 - 300	300	760	460		15960	19083	7354,0	65,57	•

Forma de pedido: Código
How to order: Code

BRIDA DE AMARRE FB FLANGE MOUNT FB

STOCK

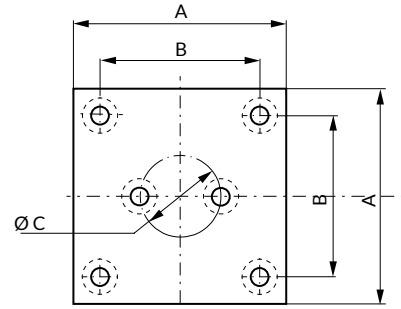
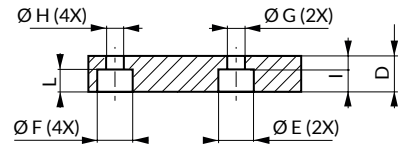
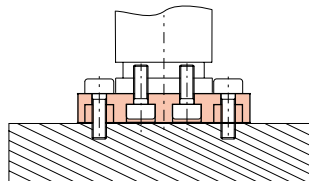
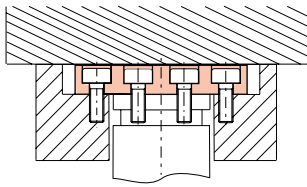

Código Code	A	B	Ø C	D	Ø E	Ø F	Ø G	Ø H	I	L
	mm	mm	mm	mm	mm	mm	mm	mm	mm	mm
FB 45*	70	50	20	20	15	15	9	9	14	12
FB 50*	75	56,5	20	20	15	15	9	9	14	12
FB 63	100	73,5	20	20	15	15	9	11	12	12

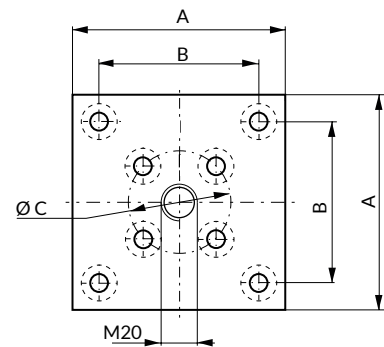
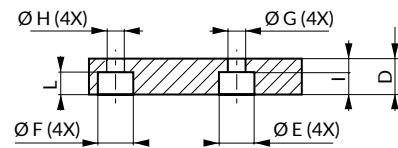
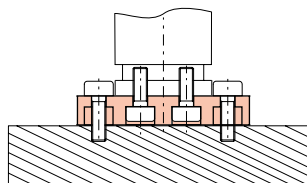
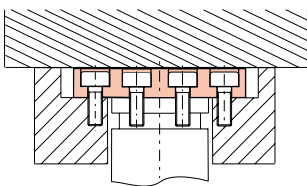

*Norma / Standard: ISO 11901-2, VDI 3003

Código Code	A	B	Ø C	D	Ø E	Ø F	Ø G	Ø H	I	L
	mm	mm	mm	mm	mm	mm	mm	mm	mm	mm
FB 75*	100	73,5	40	20	15	18	9	11	14	12
FB 95*	120	92	60	20	15	20	9	13,5	14	13
FB 120*	140	109,5	80	20	18	20	11	13,5	15	13
FB 150*	190	138	100	25	18	26	11	17,5	15	17
FB 195*	210	170	120	25	20	26	13,5	17,5	13	17

Forma de pedido: Código
How to order: Code

BRIDA DE AMARRE FBA FLANGE MOUNT FBA

STOCK

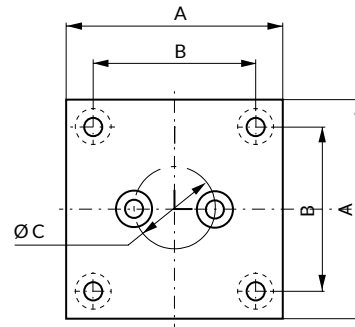
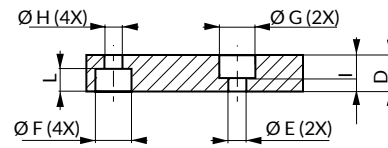
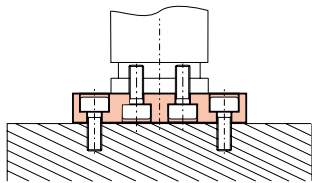

Código Code	A	B	Ø C	D	Ø E	Ø F	Ø G	Ø H	I	L
	mm	mm	mm	mm	mm	mm	mm	mm	mm	mm
FBA 45	70	50	20	20	9	18	15	11	14	12
FBA 50	75	56,5	20	20	9	18	15	11	14	12

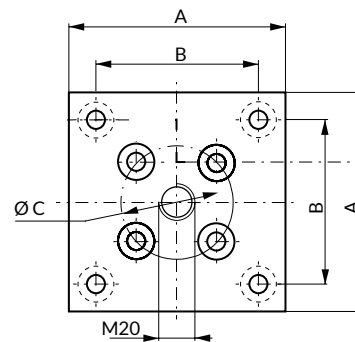
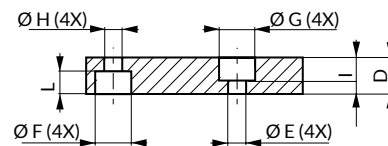
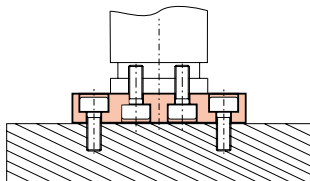

Código Code	A	B	Ø C	D	Ø E	Ø F	Ø G	Ø H	I	L
	mm	mm	mm	mm	mm	mm	mm	mm	mm	mm
FBA 75	100	73,5	40	20	9	18	15	11	14	12
FBA 95	120	92	60	20	9	20	15	13,5	14	13
FBA 120	140	109,5	80	20	11	20	18	13,5	15	13
FBA 150	190	138	100	25	11	26	18	17,5	15	17
FBA 195	210	170	120	25	13,5	26	20	17,5	15	17

Forma de pedido: Código
How to order: Code

BRIDA DE AMARRE FBB FLANGE MOUNT FBB

STOCK

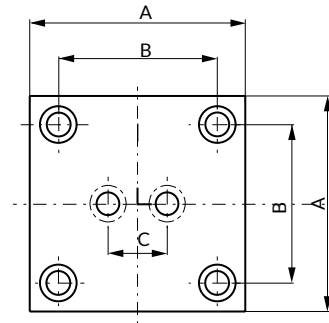
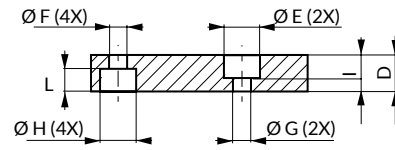
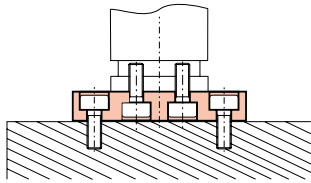

Código Code	A	B	Ø C	D	Ø E	Ø F	Ø G	Ø H	I	L
	mm	mm	mm	mm	mm	mm	mm	mm	mm	mm
FBB 45	70	50	20	20	9	15	15	9	12	12
FBB 50	75	56,5	20	20	9	15	15	9	12	12
FBB 63	100	73,5	20	20	9	18	15	11	12	12

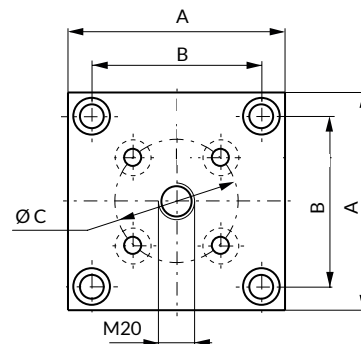
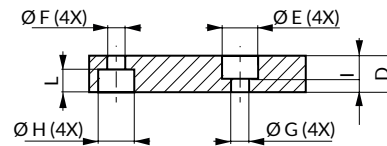
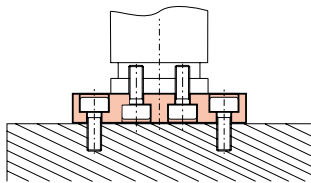

Código Code	A	B	Ø C	D	Ø E	Ø F	Ø G	Ø H	I	L
	mm	mm	mm	mm	mm	mm	mm	mm	mm	mm
FBB 75	100	73,5	40	20	9	18	15	1	12	14
FBB 95	120	92	60	20	9	20	15	13,5	14	13
FBB 120	140	109,5	80	20	11	20	18	13,5	15	13
FBB 150 A	190	138	100	20	11	20	18	13,5	15	13
FBB 195	210	170	120	25	13,5	26	20	17,5	15	17

Forma de pedido: Código
How to order: Code

BRIDA DE AMARRE FBD
FLANGE MOUNT FBD

STOCK

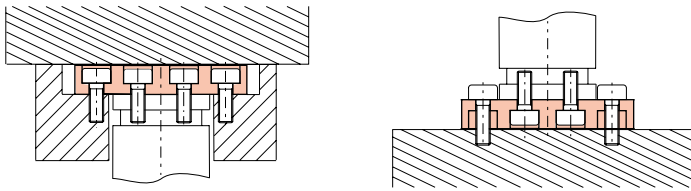
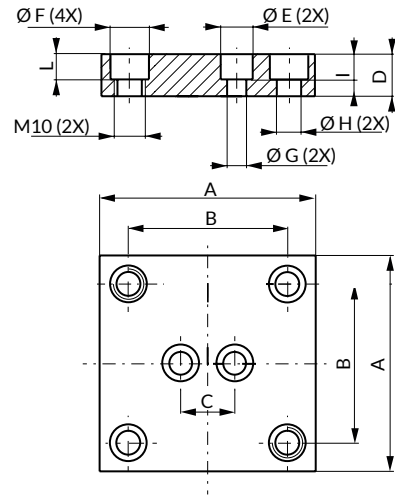

Código Code	A	B	Ø C	D	Ø E	Ø F	Ø G	Ø H	I	L
	mm	mm	mm	mm	mm	mm	mm	mm	mm	mm
FBD 45	70	50	20	20	15	15	9	9	12	12
FBD 50	75	56,5	20	20	15	15	9	9	12	12

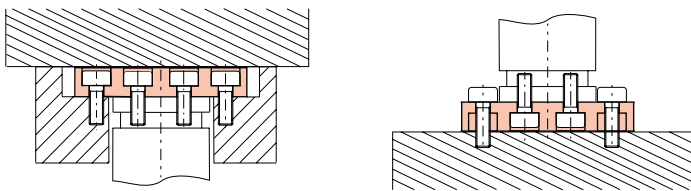
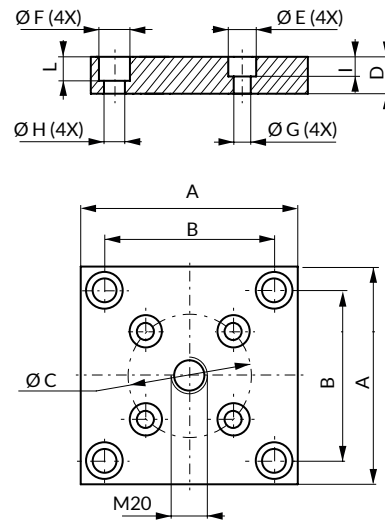

Código Code	A	B	Ø C	D	Ø E	Ø F	Ø G	Ø H	I	L
	mm	mm	mm	mm	mm	mm	mm	mm	mm	mm
FBD 75	100	73,5	40	20	15	18	9	11	12	15
FBD 150	190	138	100	20	18	26	11	17,5	15	17

Forma de pedido: Código
 How to order: Code

BRIDA DE AMARRE FS2 FLANGE MOUNT FS2

STOCK

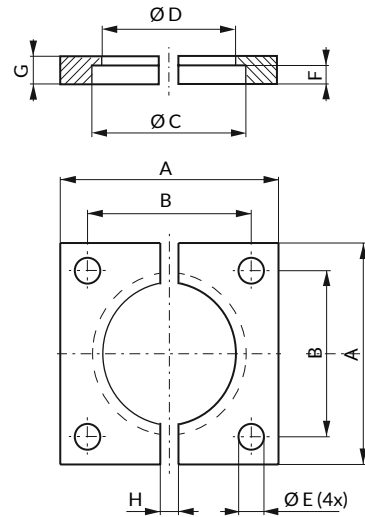

*Norma / Standard: ISO 11901-2, VDI 3003

**Norma / Standard: ISO 11901-2

Código Code	A	B	ØC	ØD	ØE	F	G	H
	mm	mm	mm	mm	mm	mm	mm	mm
FS2 32**	50	35	32,5	28,5	6,6	4	7	5
FS2 38**	55	40	38,5	34,5	7	4	7	5
FS2 45*	70	50	45,5	41,5	9	4	7	20
FS2 50*	75	56,5	50,5	44,5	9	8	12	24
FS2 63	85	63,5	63,5	57,5	11	8	12	24
FS2 75*	100	73,5	75,5	68,5	11	8	12	24
FS2 95*	120	92	95,5	88,5	13,5	8	12	24
FS2 120*	140	109,5	120,5	113,5	13,5	8	12	24
FS2 150*	190	138	150,5	143,5	17,5	8	12	24
FS2 195*	210	170	195,5	188	17,5	8	13	24

Forma de pedido: Código
How to order: Code

BRIDA DE AMARRE FS2B

FLANGE MOUNT FS2B

STOCK

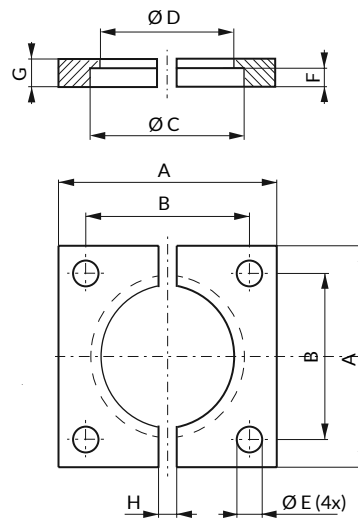
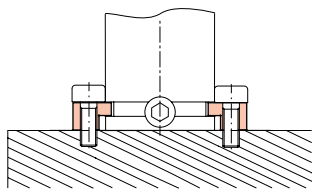
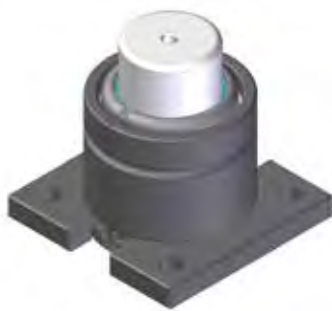

Norma / Standard: VDI 3003

Código Code	A	B	ØC	ØD	ØE	F	G	H
	mm	mm	mm	mm	mm	mm	mm	mm
FS2B 32	50	35	32,5	28,5	6,6	4	7	12
FS2B 38	55	40	38,5	34,5	6,6	4	7	12
FS2B 63	100	73,5	64	57,5	11	8	12	24

Forma de pedido: Código
How to order: Code

BRIDA DE AMARRE FS2A FLANGE MOUNT FS2A

STOCK

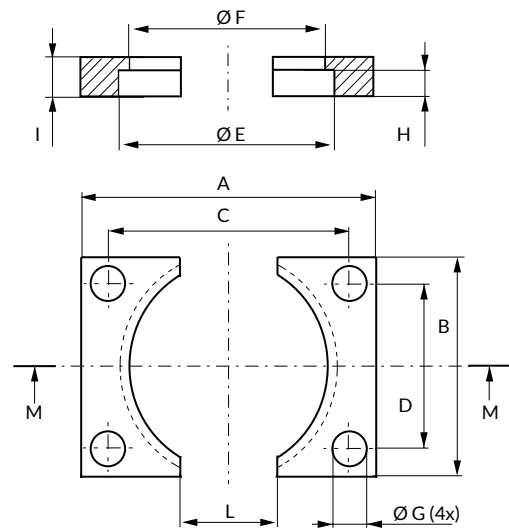
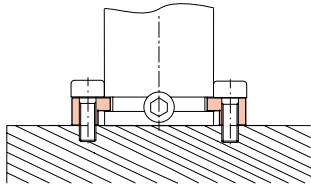
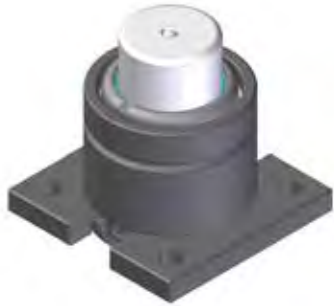

Código Code	A	B	ØC	D	ØE	ØF	ØG	ØH	I	L
	mm	mm	mm	mm	mm	mm	mm	mm	mm	mm
FS2A 32	50	27	40	18	32,5	28,5	6,6	4	7	20
FS2A 38	55	33	44	20	38,5	34,5	6,6	4	7	20
FS2A 45	70	40	57	27	45,5	41,5	9	4	7	25
FS2A 50	75	45	62	32	50,5	44,5	9	8	12	25
FS2A 63	85	58	69	42	63,5	57,5	11	8	12	30
FS2A 75	100	70	84	54	75,5	68,5	11	8	12	30
FS2A 95	120	90	100	70	95,5	88,5	13,5	8	12	40
FS2A 120	140	115	120	95	120,5	113,5	13,5	8	12	50
FS2A 150	190	145	165	120	150,5	143,5	17,5	8	12	60
FS2A 195	210	190	185	165	195,5	188	17,5	8	13	80

Forma de pedido: Código
How to order: Code

BRIDA DE AMARRE FS3 FLANGE MOUNT FS3

STOCK

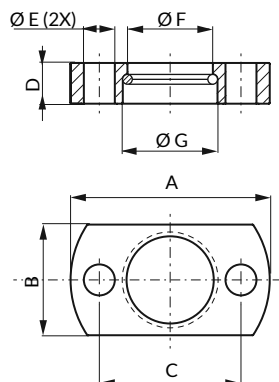
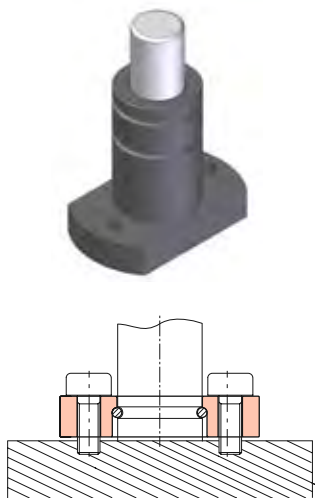

Código Code	A	B	C	D	ØE	ØF	ØG
	mm	mm	mm	mm	mm	mm	mm
FS3 19	45	25	32	9,2	7	19,3	21,4
FS3 25	50	30	38	9,2	7	25,3	27,4

BRIDA DE AMARRE FCA FLANGE MOUNT FCA

STOCK

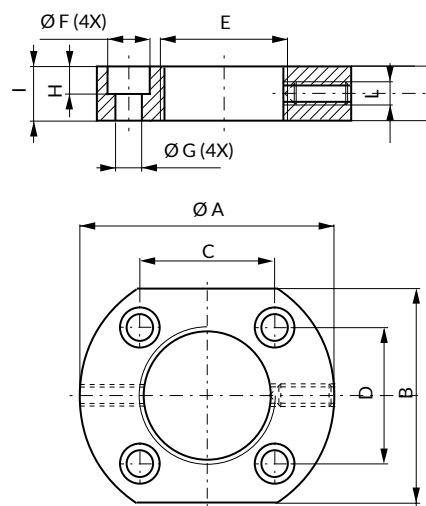

Código Code	A	B	ØC	D	ØE	ØF	ØG	ØH	I	L
	mm	mm	mm	mm	mm	mm	mm	mm	mm	mm
FCA 38	75	50	50,3	29	M 38 x 1,5	14	9	8	12	M6

Forma de pedido: Código
How to order: Code

BRIDA DE AMARRE FC-FCC FLANGE MOUNT FC-FCC

STOCK

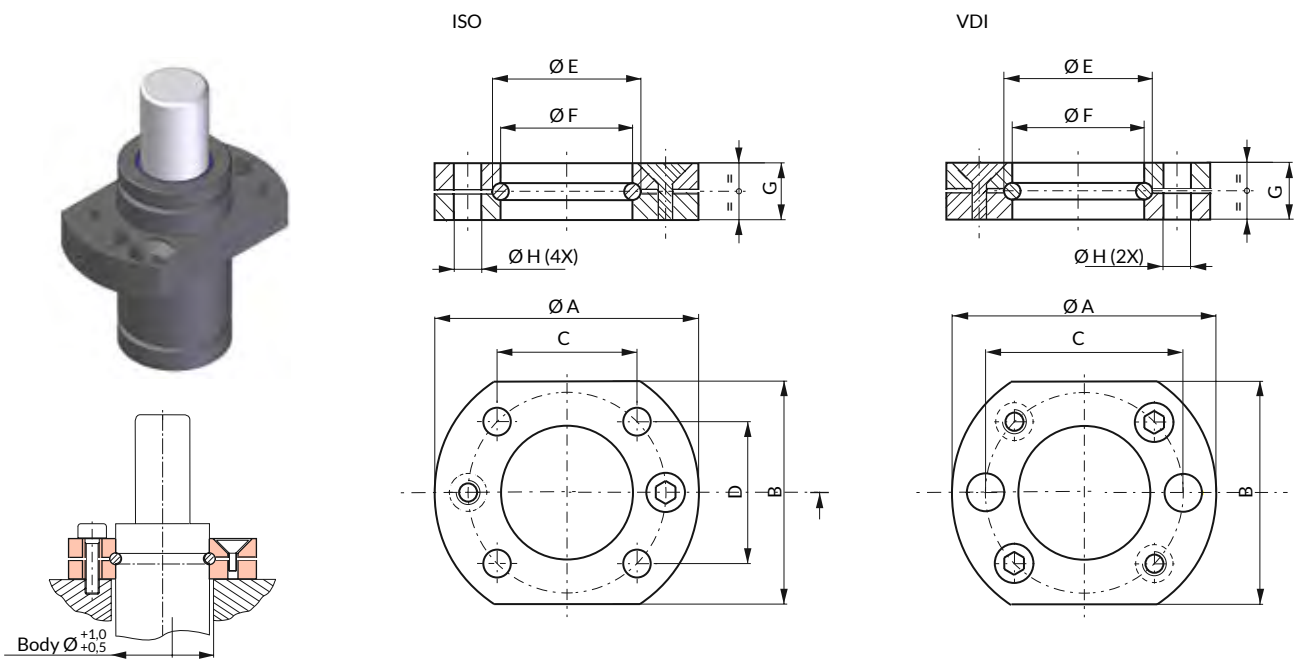

*Norma / Standard: ISO 11901-2

**Norma / Standard: VDI 3003

Código Code	A	B	ØC	ØD	ØE	F	G	H
	mm	mm	mm	mm	mm	mm	mm	mm
FC 12 A	34	21	24	-	13,7	12,5	9	6,6
FC 15 A	37	24	27	-	16,7	15,5	9	6,6
FC 19 B*	44	25	30	12	21,9	19,5	9	6,6
FC 25 B*	50	30	34	18	27,9	25,5	9	6,6
FCC 19 A**	44	25	32	-	21	19,5	9	6,6
FCC 25 A**	50	30	38	-	27	25,5	9	6,6

Forma de pedido: Código
How to order: Code

BRIDA DE AMARRE FC-FCC FLANGE MOUNT FC-FCC

STOCK

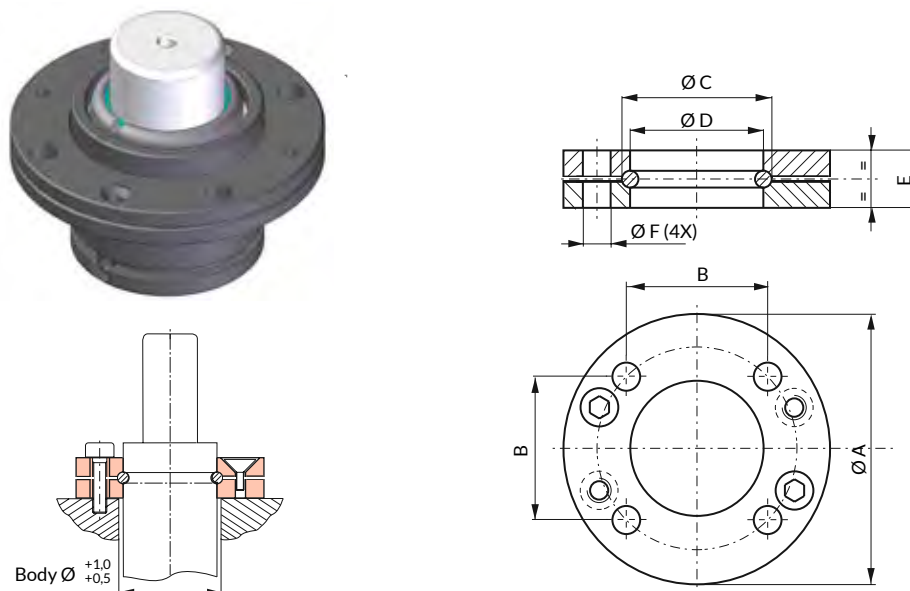

*Norma / Standard: ISO 11901-2, VDI 3003

Código Code	Ø A	B	Ø C	D	E	Ø F
	mm	mm	mm	mm	mm	mm
FC 32 A*	60	35	34	32,5	9	7
FC 38 A*	68	40	40	38,5	9	7
FC 45 A*	86	50	47	45,5	13	9
FC 50 A*	95	56,5	54	50,5	13	9
FC 63 A	122	73,5	67	63,5	16	11
FC 75 A*	122	73,5	80	75,5	16	11
FC 95 A*	150	92	100	95,5	18	13,5
FC 120 A*	175	109,5	125	120,5	21	13,5
FC 150 A*	220	138	155	150,5	27	17,5
FC 195 A*	290	170	200	195,5	27	17,5

Forma de pedido: Código
How to order: Code

BRIDA DE AMARRE FCQ-FCQC FLANGE MOUNT FCQ-FCQC

STOCK

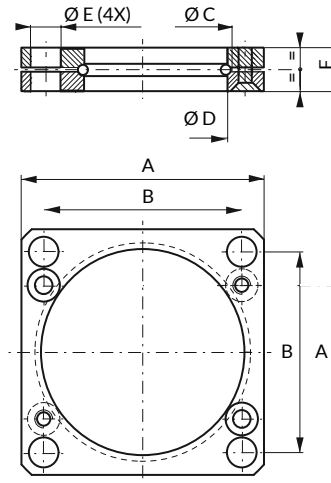
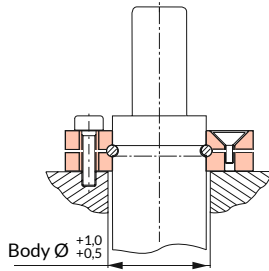
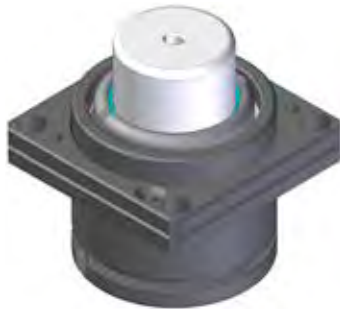

*Norma / Standard: ISO 11901-2, VDI 3003

**Norma / Standard: VDI 3003

Código Code	Ø A	B	Ø C	D	E	Ø F
	mm	mm	mm	mm	mm	mm
FCQC 32**	45	35	34	32,5	7	9
FCQC 38*	52	40	40	38,5	7	9
FCQC 45*	64	50	47	45,5	9	13
FCQC 50*	70	56,5	54	50,5	9	13
FCQ 63 A	90	73,5	67	63,45	11	16
FCQC 63**	80	64	67	63,45	11	16
FCQC 75*	90	73,5	80	75,5	11	16
FCQC 95*	110	92	100	95,5	13,5	18
FCQC 120*	130	109,5	125	120,5	13,5	21
FCQC 150*	162	138	155	150,5	17,5	27
FCQC 195*	210	170	200	195,5	17,5	27

Forma de pedido: Código
How to order: Code

BRIDA DE AMARRE FT FLANGE MOUNT FT

STOCK



FT 38 - FT 45 - FT 195

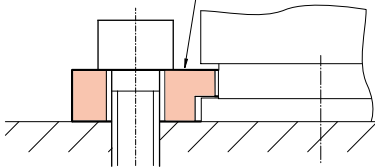

FT 50 ÷ 150

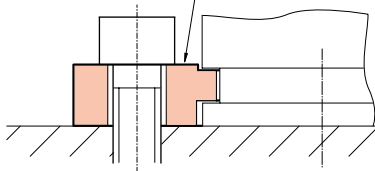

Forma / Form A

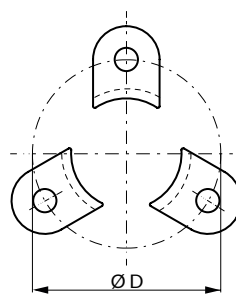

Forma / Form B

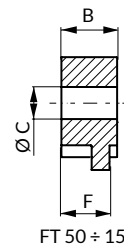
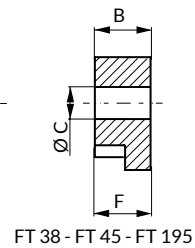
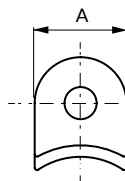
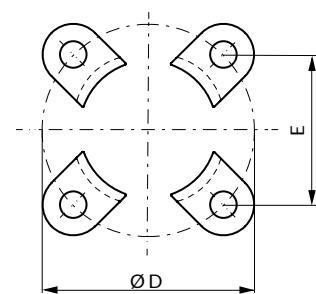

FT 38 - FT 45 - FT 195

FT 50 ÷ 150

Código Code	Ø A	B	Ø C	D	E	Ø F	Ø G	Forma / Form
	mm	mm	mm	mm	mm	mm	mm	
FT 38	20	7	7	56,6	2,23	-	7	A
FT 45	25	7	9	70,7	2,78	-	7	
FT 50	30	14,2	13	80	3,15	-	13	
FT 63	30	14,2	13	92	3,62	65	13	
FT 75	30	14,2	13	104	4,09	73,5	13	
FT 95	40	14,2	17	130	5,12	92	13	B
FT 120	50	14,2	17	155	6,1	109,5	13	
FT 150	50	14,2	21	195	7,68	138	13	
FT 195	58	16	21	240	9,45	169	16	

Forma de pedido: Código
How to order: Code

BRIDA DE AMARRE FTP FLANGE MOUNT FTP

STOCK

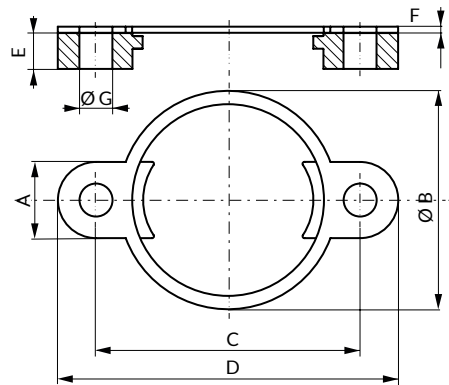
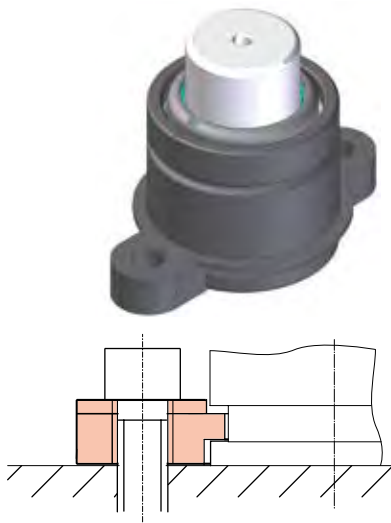

Código Code	Ø A	B	Ø C	D	E	Ø F	Ø G
	mm	mm	mm	mm	mm	mm	mm
FTP 38	20	48	56,6	76,6	7	2,5	7
FTP 45	25	56	70,7	95,7	7	2,5	9
FTP 50	30	61	80	110	14,2	2,5	13
FTP 63	30	73	92	122	14,2	2,5	13
FTP 75	30	86	104	134	14,2	2,5	13
FTP 95	40	106	130	170	14,2	2,5	17
FTP 120	50	131	155	205	14,2	2,5	17
FTP 150	50	170	195	245	14,2	2,5	21

Forma de pedido: Código
How to order: Code

BRIDA DE AMARRE FSA FLANGE MOUNT FSA

STOCK

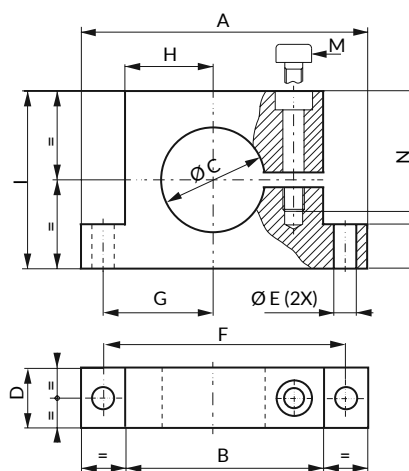
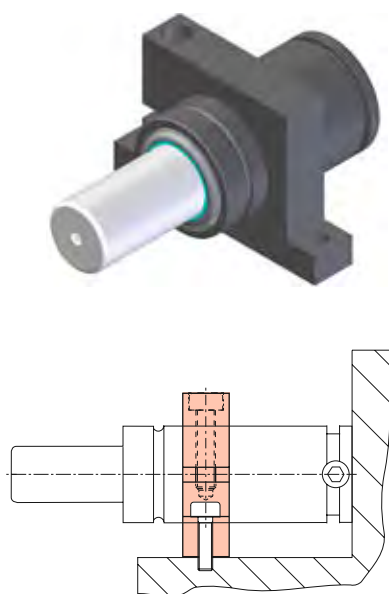

Norma / Standard: ISO 11901-2, VDI 3003

Código Code	A	B	ØC	D	ØE	F	G	H	I	L	M	N
	mm	mm	mm	mm	mm	mm	mm	mm	mm	mm	mm	mm
FSA 32	90	54	32	20	9	72	31	22	45	15	M8	39
FSA 38	95	59	38	20	9	77	34	25	55	15	M8	45
FSA 45	100	64	45	20	9	82	37	28	60	15	M8	45
FSA 50	130	90	50	30	9	110	50	40	80	20	M8	55
FSA 75	160	115	75	30	11	137	63,5	52,5	105	20	M10	80
FSA 95	195	145	95	30	13,5	170	80	67,5	125	20	M12	99,5
FSA 120	220	165	120	30	13,5	195	92,5	77,5	148	20	M12	106
FSA 150	260	200	150	30	13,5	230	110	95	200	20	M12	138

Forma de pedido: Código
How to order: Code

BRIDA DE AMARRE FSB-FSC-FSD FLANGE MOUNT FSB-FSC-FSD

STOCK

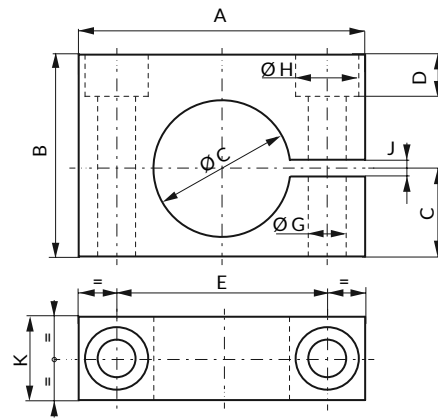
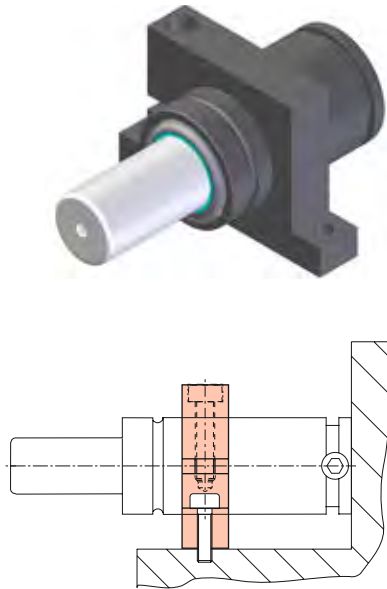

*Norma / Standard: VDI 3003

Código Code	A	B	C	D	E	ØF	ØG	ØH	J	K
	mm	mm	mm	mm	mm	mm	mm	mm	mm	mm
FSB 32	80	63	38,5	18	56	32	10,5	17	6	25
FSD 32*	68	48	20,9	10	50	32,5	9	15	4	20
FSD 38*	74	54	23,9	16	54	38,5	9	15	4	20
FSD 45*	80	60	27,5	22	60	45,5	9	15	4	20
FSD 50*	90	70	30	25	68	50,5	11	18	5	30
FSC 63	105	80	40	11	80	63	10,5	17	10	30
FSD 63*	108	82	36,5	27	84	63,5	11	18	5	30
FSD 75*	125	94	42	32	100	75,5	13,5	20	5	30
FSD 95*	140	115	52,5	33	115	95,5	13,5	20	5	30
FSD 120*	170	140	65	58	145	120,5	13,5	20	7	30
FSD 150*	200	170	80	68	175	150,5	13,5	20	7	30

Forma de pedido: Código
How to order: Code

BRIDA DE AMARRE FSE FLANGE MOUNT FSE

STOCK

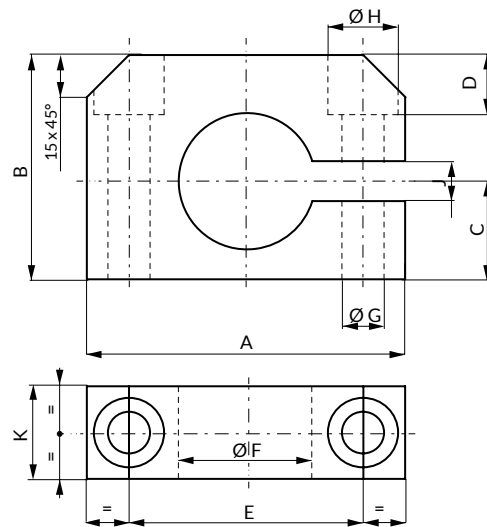
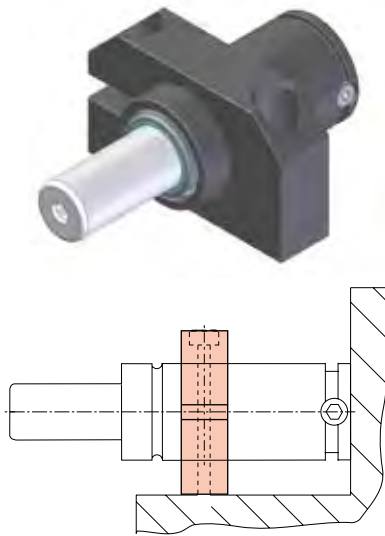

Código Code	A	B	C	D	E	ØF	ØG	ØH	J	K
	mm	mm	mm	mm	mm	mm	mm	mm	mm	mm
FSE 45	100	60	30	20	70	45,3	11	18	10	25

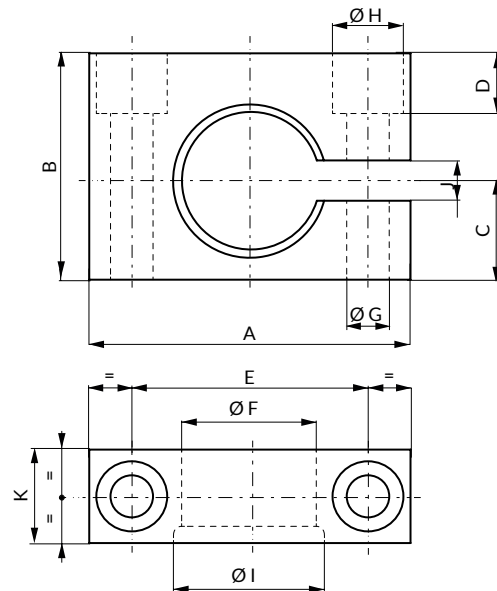
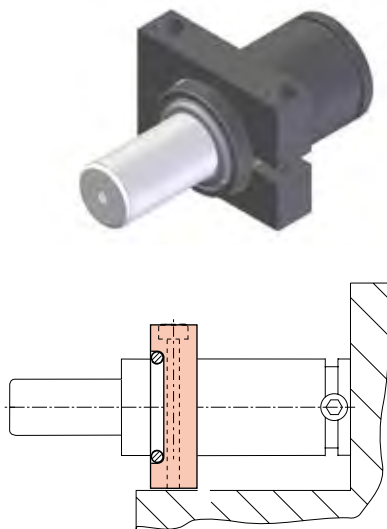

Código Code	A	B	C	D	E	ØF	ØG	ØH	ØI	J	K
	mm	mm	mm	mm	mm	mm	mm	mm	mm	mm	mm
FSE 50	90	70	30	25	68	50,3	11	18	54,1	10	30
FSE 75	125	94	42	19	100	75,3	13	20	80,1	10	30

Forma de pedido: Código
How to order: Code

BRIDA DE AMARRE R FLANGE MOUNT R

STOCK

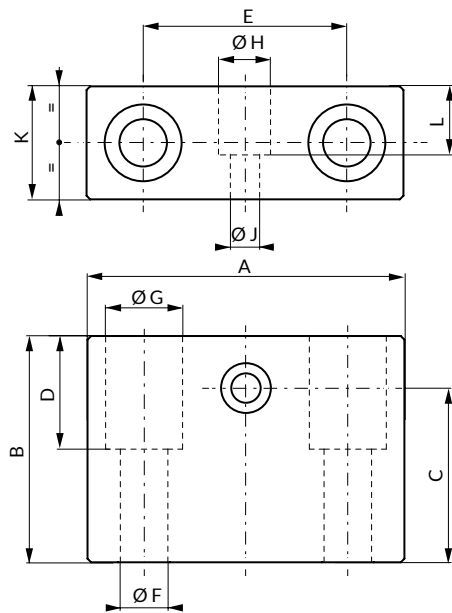
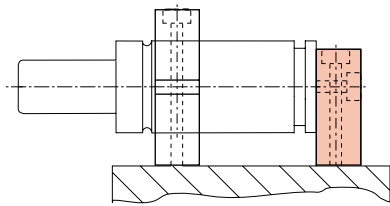

Código Code	A	B	C	D	E	ØF	ØG	ØH	ØJ	L	K
	mm	mm	mm	mm	mm	mm	mm	mm	mm	mm	mm
R 32 A	70	50	38,5	25	45	10,5	17	11	6,5	15	25

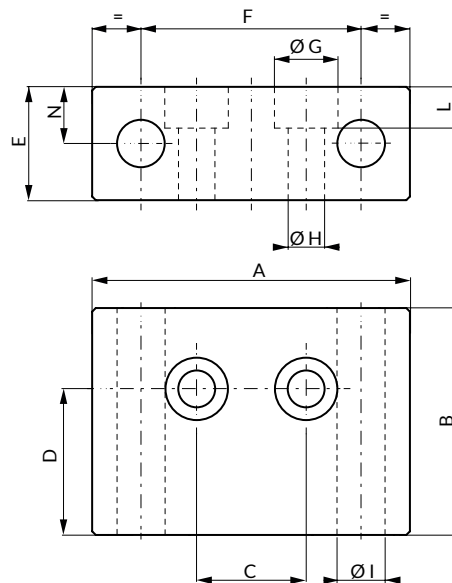
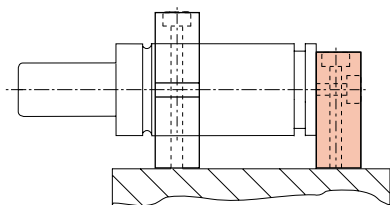

Código Code	A	B	C	D	E	F	ØG	ØH	L	ØI	N
	mm	mm	mm	mm	mm	mm	mm	mm	mm	mm	mm
R 50 A	65	45	20	30	28	44	14	9	10	11	13
R 75 A	80	45	28,3	27,8	28	57	14	9	10	14	12
R 95 A	95	45	42,4	31,2	28	70	14	9	10	14	15

Forma de pedido: Código
How to order: Code

BRIDA DE AMARRE GM FLANGE MOUNT GM

STOCK

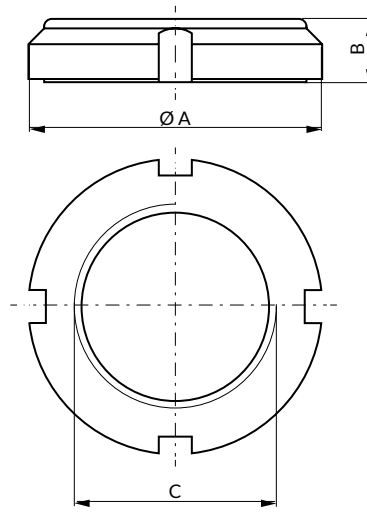
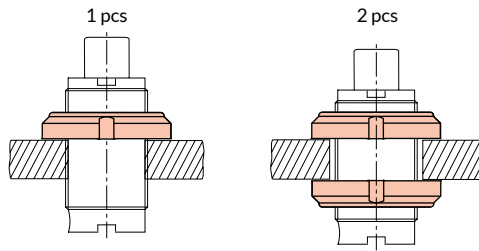

Código Code	Ø A	B	C
	mm	mm	mm
GM.38	53	12	M 38 X 1,5

BRIDA DE AMARRE DM FLANGE MOUNT DM

STOCK

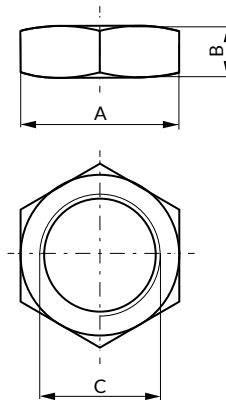
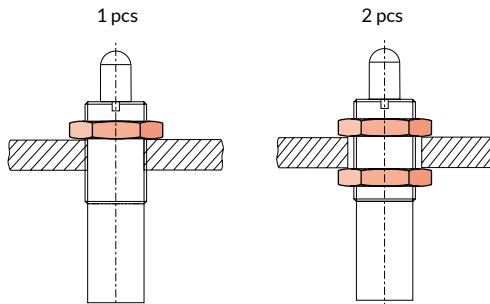

Código Code	Ø A	B	C
	mm	mm	mm
DM 16	S24	8	M 16 x 1,5
39DM16X2A	S24	8	M 16 x 2
39DI5/8-11A	S26	9	5/8" - 11 UNC

Forma de pedido: Código
How to order: Code

CILINDROS CONECTADOS LINKED SYSTEM CONNECTED GAS SPRINGS LINKED SYSTEM

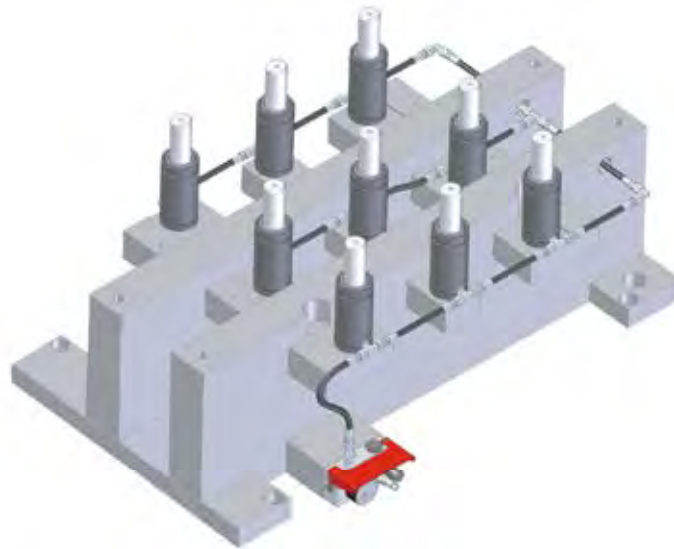

VENTAJAS

- La misma presión en todos los cilindros
- Control de la presión = control de la fuerza
- Aumento/reducción de la presión = aumento/reducción de la fuerza mediante el panel de control, incluso durante la estampación sin actuación directa sobre los cilindros
- Pueden emplearse pulmones de compensación para reducir el aumento de la presión al final de la compresión
- Gestión de equipos y fuerzas distintas sobre el mismo troquel (uso multipanel MCPC+AUMCP)
- Parada de emergencia con presostato
- Tapón de seguridad con disco de ruptura CE
- Flexibilidad de conexión con mangueras y racores EO - 24°, JIC 37°, Minimes, Micro 32°, ORFS



Los cilindros conectables (código modelo + N/NA) se sirven sin válvula unidireccional y con cuerpo/base especiales en los casos en que se requieran. En algunas series, los cilindros autónomos pueden transformarse en cilindros conectables simplemente quitando la válvula de estanqueidad del orificio de carga. Antes de realizar esta operación, vaciar completamente la presión. Si fuera necesario quitar cualquiera de los componentes de la instalación, vaciar completamente la presión mediante el panel de control.

BENEFITS

- Same pressure in all GAS SPRINGS
- Pressure control = force control
- Increase/decrease of pressure = increase/decrease of force by control panel even during stamping operation without direct acting to the GAS SPRINGS
- Lower pressure increase by using compensation tank
- Possibility to manage different systems and forces in the same tool by using the multipanel MCPC+AUMCP
- Safe stop function through pressure switch
- Use of the safety plug with rupture disc CE
- Flexible linking by using hose and connection EO -24°, JIC 37°, Minimes, Micro 32°, ORFS and couplings and many useful accessories



The hoses system GAS SPRINGS (model code + N/NA) are supplied without charging valve and with special body/end plate when specified.

However S/SC/H/KE/RV/RS/RF/RG/RT/LS series can be converted from self-contained to hoses system by simply removing the charging valve. Be sure that all pressure is exhausted before starting this operation. In case it's necessary to remove any of the installed components, pressure must be fully exhausted through the control panel.

CILINDROS CONECTADOS EASY MANIFOLD CONNECTED GAS SPRINGS EASY MANIFOLD

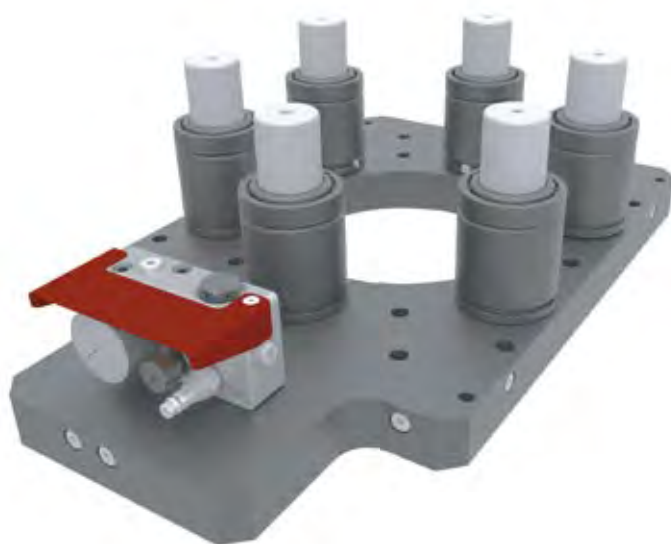

CARACTERÍSTICAS:

- Ventajosa alternativa a los tradicionales y costosos cilindros Manifold.
- Gran variedad de combinaciones con el uso de cilindros estándar.
- Total eliminación de mangueras y racores.
- Presión uniforme en el sistema
- Fácil mantenimiento, igual a la de los cilindros estándar.
- Placas de conexión realizables directamente por los usuarios
- Máxima flexibilidad de realización del sistema
- No se requiere ninguna herramienta especial para la instalación
- Podemos proporcionar las placas según especificaciones del cliente, Comprobadas y listas para la instalación.

CHARACTERISTICS:

- An advantageous alternative to conventional and expensive. Manifold GAS SPRINGS.
- Large variety of combinations with the use of standard GAS SPRINGS.
- Total elimination of hoses and connections.
- Balanced pressure in the system
- Easy maintenance the same as standard GAS SPRINGS.
- Connection plates can be made directly by users.
- Maximum flexibility in creation of systems.
- No special tools required for installation.
- We can supply the plates supply the plates/cushion to customer specifications, tested and ready for installation.

PROTECCIÓN PROTECTION



SW

Rascador de vástago secundario
Secondary rod wiper



Beneficios / Benefits

- Excelente protección contra los contaminantes líquidos y sólidos.
 - Poliuretano de altas prestaciones para una máxima resistencia química a los lubricantes de alto rendimiento.
 - Mayor vida útil para elementos de guía y juntas dinámicas.
 - Mínima pérdida de carrera nominal.
 - Fácil de colocar.
 - Ninguna limitación para el posicionamiento del cilindro.
- Excellent protection from liquid and solid contaminants.
 - Maximum chemical resistance to lubricants thanks to high performance polyurethane.
 - Longer lifetime for guiding elements and dynamic seals.
 - Minimal loss of nominal stroke.
 - Easy to insert.
 - No restrictions when positioning the GAS SPRING.



Consultar versiones con SKUDO
Ask about models with SKUDO

SKUDO

Protección activa contra Contaminantes
Protection from Contaminants Activer



Beneficios / Benefits

- Elimina daños de contaminantes a los componentes que garantizan la estanqueidad y guiado.
 - Aumenta significativamente la vida del cilindro en presencia de contaminantes líquidos y sólidos.
 - No aumenta la altura del cilindro.
 - Es una protección que no sufre desgaste.
- Eliminates damages to guiding and sealing components caused by contaminants.
 - Significantly increases the life of GAS SPRINGS used in severe working environments.
 - Does not alter the height of the GAS SPRING.
 - Does not wear out.

RASCADOR SECUNDARIO SW SECONDARY WIPER SW



Ofrecemos una gama completa de rascadores secundarios para mejorar las prestaciones de los cilindros de nitrógeno utilizados en entornos muy contaminados. Los nuevos rascadores secundarios de poliuretano están diseñados para un ajuste perfecto con varios modelos de cilindros de nitrógeno. Consulte las tablas para datos técnicos.

Los rascadores secundarios se pueden pedir por separado de los cilindros y ser montados por el usuario o, si se solicita en el pedido, se instalan directamente en fábrica.

We offer a complete range of secondary wipers to improve performances of nitrogen GAS SPRINGS used in heavy contaminated environments.

The new secondary wipers, made in polyurethane, are designed for a perfect fitting with many series of nitrogen GAS SPRINGS.

See the charts for technical data.

The secondary wipers can be ordered separately from the GAS SPRINGS. They can be assembled by user or, if requested with the order, by us.

Código de Cilindro GAS SPRING Code	A	B	Ø D	Código de Rascador Secundario Secondary Wiper Code
	mm	mm	mm	
M50	-	9,5	15	59SW023
M70	-	9,5	18	59SW024
M90	0,5	10,5	22	59SW045
M200	0,5	10,5	28	59SW046
M 300	2	4	-	59SW001
RV170	1,5	9,5	22	59SW027
RV320	1,5	9,5	28	59SW028
RV 500	2	4	-	59SW003
RV 750	2	4	-	59SW004
RV 1000	2	5	-	59SW005
RV 1200	2	5	-	59SW005
RV 1500	2,5	5,5	-	59SW006
RV 2400	2,5	5,5	-	59SW007
RV 4200	2,5	5,5	-	59SW008
RV 6600	2,5	5,5	-	59SW009
RV 9500	3	6	-	59SW010
RV 12000	3	6	-	59SW011
RV 20000	3	6	-	59SW012

Código de Cilindro GAS SPRING Code	A	B	Código de Rascador Secundario Secondary Wiper Code
	mm	mm	
SC 150	2	4	59SW014
SC 250	2	4	59SW015
SC 500	2	4	59SW016
SC 750	2	5	59SW017
SC 1500	2,5	5,5	59SW018
SC 3000	2,5	5,5	59SW019
SC 5000	3	6	59SW020
SC 7500	3	6	59SW021
SC 10000	3	6	59SW022

A= Reducción de Carrera Nominal / Nominal stroke reduction

Cu= Carrera Nominal / Nominal Stroke



Para montar el rascador secundario es necesario quitar el indicador de sobrecarrera OSM.
The installation of the secondary wiper will require the removal of the active safety marker OSM where mounted.

SEGURIDAD SAFETY



Over
Stroke
Active
Safety

VDI
3003



Seguridad activa de fin de carrera Over Stroke Active Safety

- Descarga la presión de manera controlada y completa en caso de que el cilindro sobrepase su carrera máxima.

- Exhausts pressure in a controlled and complete manner, when the GAS SPRING has been overstroked.

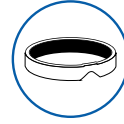
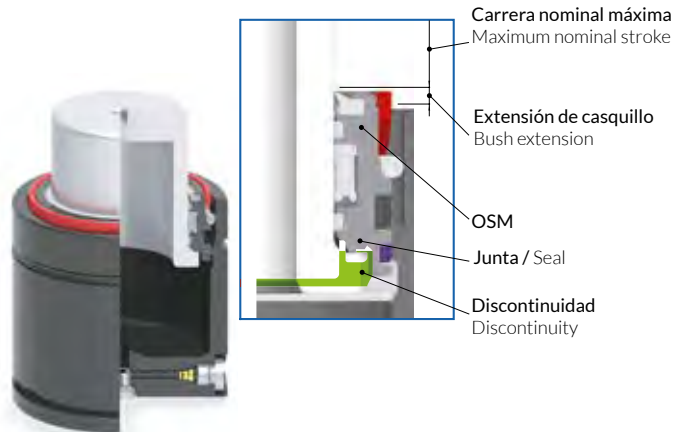

Over
Stroke
Marker

Marcador de Sobrecarrera OSM The Over Stroke Marker OSM

- Permite ver inmediatamente que el cilindro ha sido utilizado por encima de la carrera nominal máxima.
- Confirma que el dispositivo de seguridad contra sobre carreras OSAS ha sido activado.
- Permite actuar con rapidez en el troquel para eliminar la causa de la sobrecarrera.
- No limita el posicionamiento del cilindro.
- Aumenta la seguridad del usuario de los cilindros de nitrógeno.

- Enables you to see immediately that the GAS SPRING has been used over its maximum nominal stroke.
- Confirms that the Over Stroke Safety Feature OSAS has been activated.
- Allows you to act promptly on the die to remove the cause of the over stroke.
- Doesn't restrict the free positioning of the GAS SPRING.
- Improves user safety for nitrogen GAS SPRINGS.

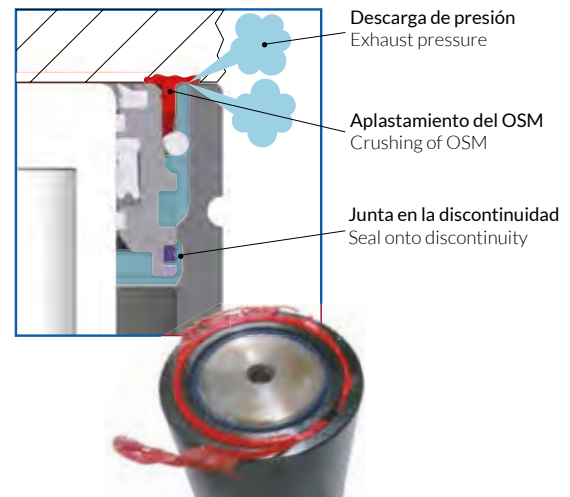

Beneficios / Benefits

- Reduce el riesgo de daños y peligros consecuencia de la proyección de partes bajo presión.
- Se activa automáticamente sin intervención del usuario.
- No aumenta el precio del cilindro.

- Reduces the risk of tool damage or injury due to ejection of parts under pressure.
- Self activates auto-matically regardless of users intervention.
- Does not increase the price of GAS SPRINGS.

Si se activan los dispositivos de seguridad, verificar y descargar toda la presión residual, eliminar las causas de los daños y reemplazar siempre el cilindro dañado.

If the safeguard devices are activated, verify and exhaust the possible pressure leftovers, remove the causes of the damage and replace always the damaged GAS SPRING.



Uncontrolled
Speed
Active
Safety

VDI
3003



Seguridad Activa de Retorno Incontrolado Uncontrolled Speed Active Safety

- Descarga la presión de manera controlada y completa en caso de que el cilindro sufra un retorno incontrolado.

- Exhausts pressure in a controlled and complete manner when the GAS SPRING has been stressed by uncontrolled returns.

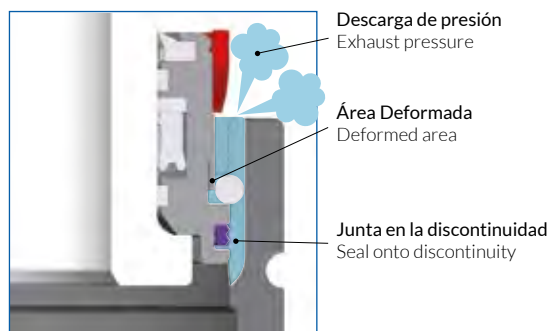
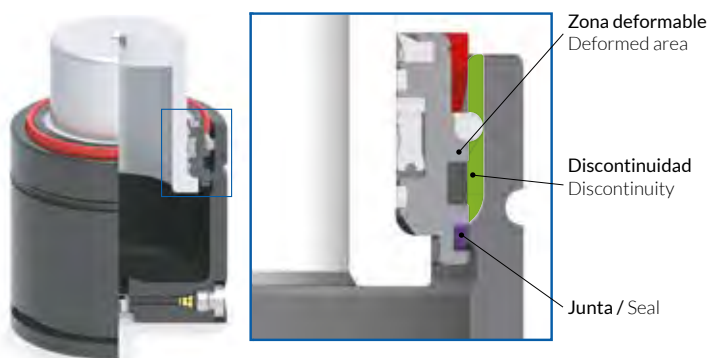

Over
Pressure
Active
Safety

VDI
3003



Seguridad Activa por Sobre Presión Over Pressure Active Safety

- Descarga la presión de manera controlada y completa cuando se supera el valor máximo permitido.

- Exhausts the pressure in a controlled and complete manner when it exceeds the maximum allowed value.

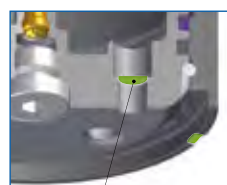

Septo de ruptura
Rupture septum



Fresado de descarga
Exhaust milling

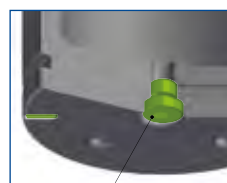

Tapón de ruptura
Rupture plug

Beneficios / Benefits

- Reduce el riesgo de daños y peligros consecuencia de la proyección de partes bajo presión.
- Se activa automáticamente sin intervención del usuario.
- No aumenta el precio del cilindro.

- Reduces the risk of tool damage or injury due to ejection of parts under pressure.
- Self activates auto-matically regardless of users intervention.
- Does not increase the price of GAS SPRINGS.

Si se activan los dispositivos de seguridad, verificar y descargar toda la presión residual, eliminar las causas de los daños y reemplazar siempre el cilindro dañado.

If the safeguard devices are activated, verify and exhaust the possible pressure leftovers, remove the causes of the damage and replace always the damaged GAS SPRING.

ELEMENTOS DE SUJECIÓN FASTENING ELEMENTS



Cada uno de los elementos de esta gama cumple la función de mantener la unión mecánica removible entre dos o más componentes. En este apartado podrás encontrar elementos de bridaje para el amarre y sujeción del troquel, así como elementos de tornillería necesaria para su montaje.

Each of the elements in this range fulfills the function of maintaining the removable mechanical connection between two or more parts of an application. Our range of fastening elements is composed of a selection of clamping elements for fastening the die, as well as screwing elements needed in the manufacturing process of it.

ELEMENTOS DE SUJECIÓN

FASTENING ELEMENTS

ÍNDICE INDEX

348

**BRIDAS DE AMARRE RÁPIDO
BAR**
COMBINED SLIDING CLAMP **BAR**



349

**BRIDAS DE AMARRE RÁPIDO
CON TORNILLO Y TUERCA
BAR + BAR-S + BAR-T**
CLAMP WITH SCREW
AND NUT **BAR + BAR-S + BAR-T**



349

**BRIDA CON TORNILLO, TUERCA
Y PATÍN ELEVADOR BAR + BAR-S
+ BAR-T + BAR-P**
CLAMP WITH SCREW, NUT AND
BOTTOM SUPPORT **BAR + BAR-S
+ BAR-T + BAR-P**



350

**BRIDAS CON TORNILLO
FIJACIÓN BAR + BAR-S**
CLAMP WITH FIXING SCREW
BAR + BAR-S



350

PATÍN ELEVADOR BAR-P
BOTTOM SUPPORT **BAR-P**



351

TORNILLO FIJACIÓN BAR-S
FIXING SCREW **BAR-S**



351

TUERCA BAR-T
NUT **BAR-T**



352

CÁLCULO DE APLICACIÓN
CÁLCULO DE APLICACIÓN

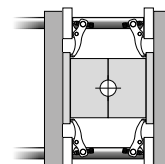

353

ARANDELA ARZ
WASHER **ARZ**



DIN 125

354

ARANDELA ARN
WASHER **ARN**



-

355

TUERCA TRZ
NUT **TRZ**



DIN 934

356

TORNILLO TCO
SCREW **TCO**



DIN 7991

357

TORNILLO TCC
SCREW **TCC**



DIN 912

358

TORNILLO TOPE GUÍA TT
SHOULDER SCREW **TT**



ISO 7379

359

TORNILLO TOPE GUÍA 1021 TL
SHOULDER SCREW **1021 TL**



-

360

TORNILLO LIMITADOR SVC
LIMITING SCREW **SVC**



-

361

PASADOR CILÍNDRICO **PC**
CYLINDRICAL DOWEL PIN **PC**



DIN 6325

362

PASADOR CILÍNDRICO
ROSCADO **PRN**
CYLINDRICAL DOWEL PIN WITH
THREAD AND NUT **PRN**



DIN 7979

363

PASADOR ANTI GRIPANTE **PRS**
ANTI SEIZE DOWEL PIN **PRS**



DIN 7979

364

CASQUILLO DE RETENCIÓN
PARA PASADOR **CRP**
DOWEL PIN RETAINING SLEEVE
CRP



-

365

HERRAMIENTA PARA EXTRACCIÓN
DE PASADORES **HECM**
DOWEL PIN EXTRACTOR **HECM**



-

366

BASE MAGNÉTICA ALTA **BM1AL**
HIGH MAGNETIC BASE **BM1AL**



-

366

BASE MAGNÉTICA BAJA **BM2AL**
LOW MAGNETIC BASE **BM2AL**



-

367

IMÁN REDONDO **IM1AL**
ROUND MAGNET **IM1AL**



-

367

IMÁN RECTANGULAR **IM2AL**
RECTANGULAR MAGNET **IM2AL**



-

368

IMÁN BOTÓN **IM3AL**
BUTTON MAGNET **IM3AL**



-

368

IMÁN DISCO NEODIMIO **IM4ND**
NEODYMIUM DISC MAGNET
IM4ND



-

369

BASE ALTA SANDWICH LISA
BM3_
HIGH PLAIN SANDWICH BASE
BM3_



-

370

BASE ALTA SANDWICH CON
AGUJERO DE ROSCADO
BM3NDH
HIGH SANDWICH BASE WITH
THREAD **BM3NDH**



-

371

BASE ALTA LISA **BM4_ - BM5_**
HIGH PLAIN BASE **BM4_ - BM5_**



-

372

BASE ALTA CON AGUJERO DE
ROSCADO **BM5H_**
HIGH BASE WITH THREAD **BM5H_**



-

373

BASE BAJA LISA **BM6_**
LOW PLAIN BASE **BM6_**



-



374

**BASE BAJA CON AGUJERO
PASANTE [BM6T_](#)**
LOW PLAIN BASE WITH THRU
HOLE [BM6T_](#)



375

**BASE BAJA CON AGUJERO
PASANTE ROSCADO [BM6R_](#)**
LOW PLAIN BASE WITH THREAD
[BM6R_](#)



376

**BASE BAJA TETÓN ROSCA
HEMBRA [BM7_](#)**
LOW BASE ROUND (GRIP) WITH
THREAD [BM7_](#)



377

**BASE BAJA TETÓN ROSCA
MACHO [BM7M_](#)**
LOW BASE ROUND (GRIP) WITH
SCREW [BM7M_](#)



378

PINZAS MAGNÉTICAS [PZM](#)
MAGNETIC CLIPS [PZM](#)



BRIDAS DE AMARRE RÁPIDO BAR COMBINED SLIDING CLAMP BAR

STOCK

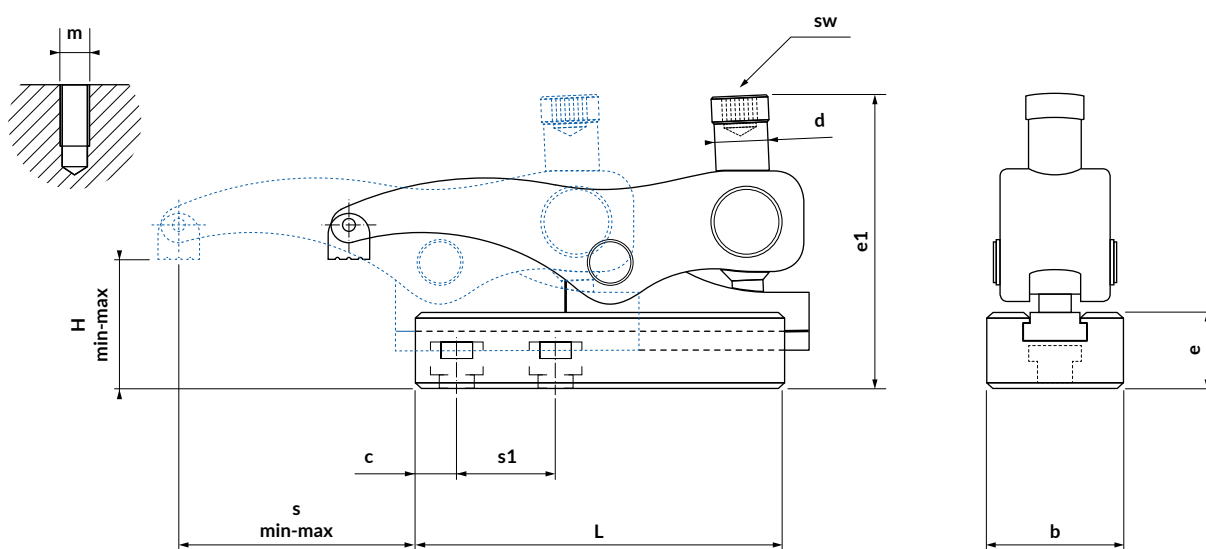

Fuerza sujeción Clamping Force Kgf	m	H mín.	H máx.	s	s1	e1	d	sw	L	e	b	c	k	Cotas para montaje con tuerca y patin elevador Dimensions for assembly with nut & bottom support				
														J1	J2	J3	hp min	hp max
														1600	Consultar opciones de tornillo BAR-S Please consult BAR-S screw options	0	50	12-66
2000		0	60	15-83	30	113	M18	10	130	39	48	17,5	22	158	83	45	45	105
2500		0	65	18-96	35	125	M20	12	140	43	55	19,5	26	173	90	48	48	113
5500		20	80	17-92	41,5	175	M24	12 24	178	55	74	24	34	235	114	59	79	139

Forma de pedido: BAR + Fuerza sujeción
How to order: BAR + Clamping force

Ventajas:

- 1600 kgf - 5500 kgf de fuerza de sujeción.
- Usos en agujero y canal "T".
- Posibilidad fijación en varias posiciones deslizando sobre la pletina.
- Sujeta a altas y bajas distancias sin soporte con el perno.
- Rápida y fácil sujeción gracias a su estructura práctica.

Advantages:

- 1600 kgf - 5500 kgf Clamping Force.
- Can be used in hole and "T" channel.
- It can be fixed in various positions by sliding on the slide.
- It clamps high and low distances without support with the imbus bolt.
- It provides rapid and easy connection due to its practical structure.

BRIDAS DE AMARRE RÁPIDO CON TORNILLO Y TUERCA BAR + BAR-S + BAR-T
CLAMP WITH SCREW AND NUT BAR + BAR-S + BAR-T

STOCK

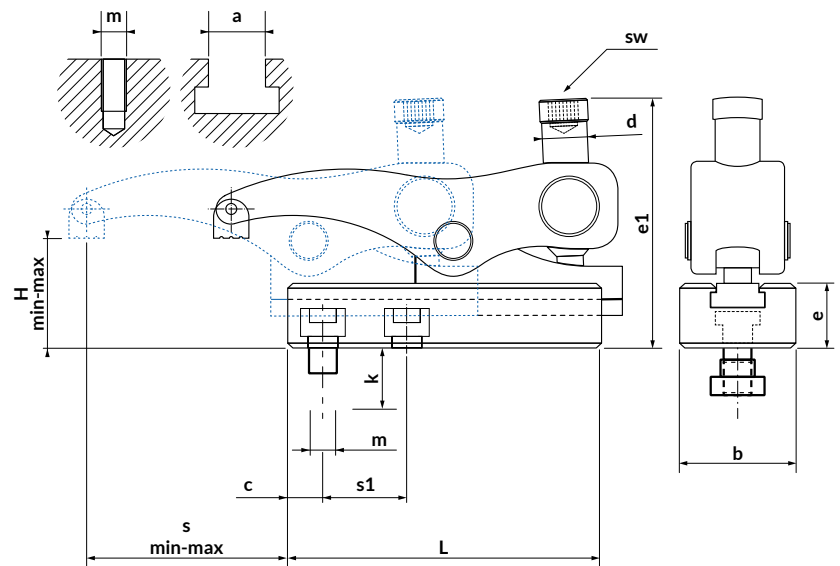

Forma de pedido: Ref. Brida + Ref. Tornillo + Ref. Tuerca
 Ejemplo de pedido¹: BAR-1600 + BAR-S1016 + BAR-T1012
 Ejemplo de pedido²: BAR-1600 + BAR-S1216 + BAR-T1214
 How to order: Clamp Ref. + Screw Ref. + Nut Ref.
 Example¹: BAR-1600 + BAR-S1016 + BAR-T1012
 Example²: BAR-1600 + BAR-S1216 + BAR-T1214

BRIDA CON TORNILLO, TUERCA Y PATÍN ELEVADOR BAR + BAR-S + BAR-T + BAR-P
CLAMP WITH SCREW, NUT AND BOTTOM SUPPORT BAR + BAR-S + BAR-T + BAR-P

STOCK

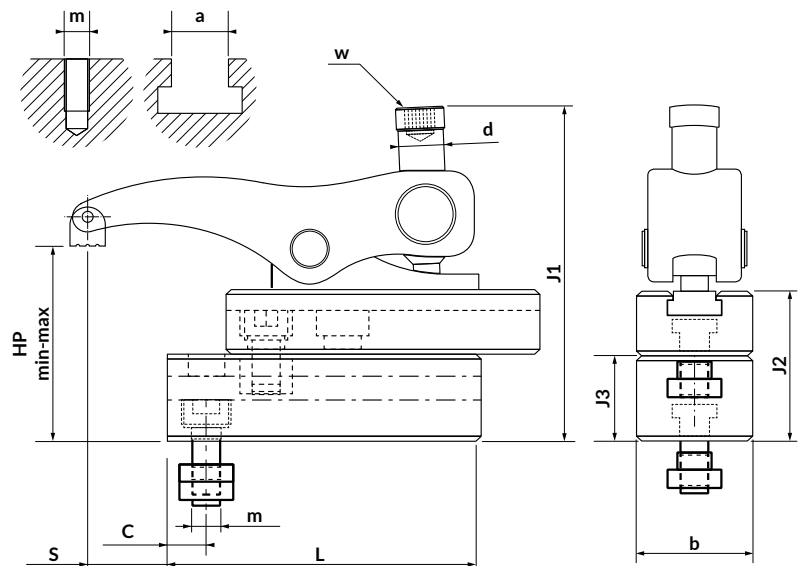

Forma de pedido: Ref. Brida + Ref. Tornillo + Ref. Tuerca + Ref. Patín
 Ejemplo de pedido¹: BAR-1600 + BAR-S1016 + BAR-T1012 + BAR-P1600
 Ejemplo de pedido²: BAR-1600 + BAR-S1216 + BAR-T1214 + BAR-P1600
 How to order: Clamp Ref. + Screw Ref. + Nut Ref. + Bottom Ref.
 Example¹: BAR-1600 + BAR-S1016 + BAR-T1012 + BAR-P1600
 Example²: BAR-1600 + BAR-S1216 + BAR-T1214 + BAR-P1600

i El patín elevador requiere tornillo y tuerca para sujeción a brida. Consultar forma de pedido de BAR-P.
 The sliding clamp requires screw and nut to fasten to clamp.
 Please consult how to order BAR-P.

BRIDAS CON TORNILLO FIJACIÓN BAR + BAR-S
CLAMP WITH FIXING SCREW BAR + BAR-S

STOCK

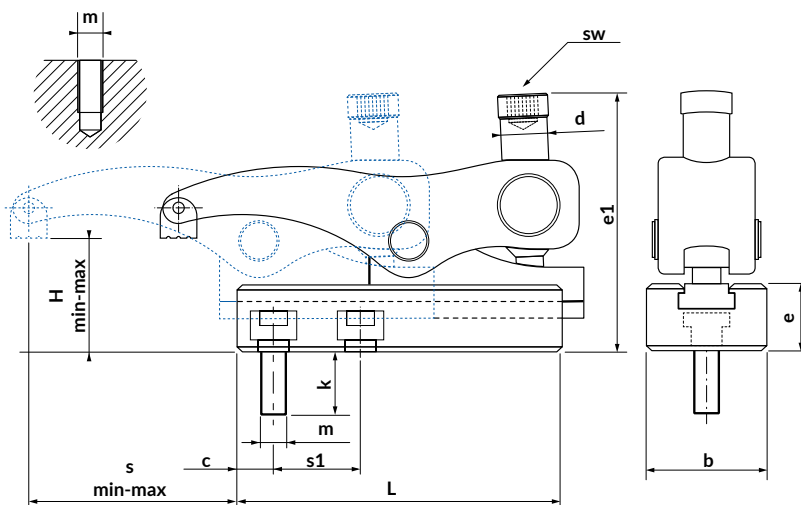

Forma de pedido: Ref. Brida + Ref. Tornillo

Ejemplo de pedido¹: BAR-1600 + BAR-S1016Ejemplo de pedido²: BAR-1600 + BAR-S1216

How to order: Clamp Ref. + Screw Ref.

Example¹: BAR-1600 + BAR-S1016Example²: BAR-1600 + BAR-S1216

PATÍN ELEVADOR BAR-P
BOTTOM SUPPORT BAR-P

STOCK

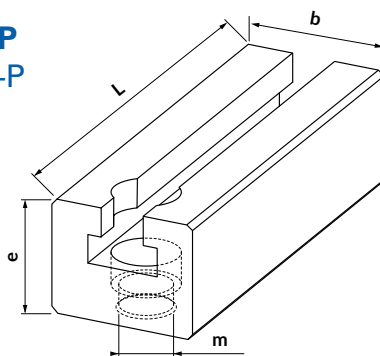
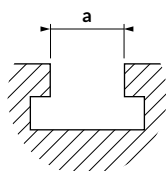

Referencia Reference n°	m	Patín elevador Bottom support			
		a	L	b	e
BAR-P1600	M10	14	104	38	38
	M12				
BAR-P2000	M12	14	130	48	45
	M16				
BAR-P2500	M16	18	140	55	48
	M18				
BAR-P5500	M20	28	178	74	59
	M20				
	M24				

Tornillo Screw	Tuerca Nut
Referencia Reference n°	Referencia Reference n°
BAR-S1216	BAR-T1214
BAR-S1220	BAR-T1214
BAR-S1624	BAR-T1618
BAR-S2434	BAR-T2428

i Este artículo requiere tornillo y tuerca para sujeción a brida.
Los tres artículos se suministran por separado.
This article requires screw and nut to fasten to clamp.
the three articles need to be ordered separately.

Forma de pedido: Ref. Patín + Ref. Tornillo + Ref. Tuerca
Ejemplo de pedido¹: BAR-P1600 + BAR-S1216 + BAR-T1214
Ejemplo de pedido²: BAR-P2000 + BAR-S1220 + BAR-T1214

How to order: Bottom Ref. + Screw Ref. + Nut Ref.
Example¹: BAR-P1600 + BAR-S1216 + BAR-T1214
Example²: BAR-P2000 + BAR-S1220 + BAR-T1214

TORNILLO FIJACIÓN BAR-S
FIXING SCREW BAR-S

STOCK

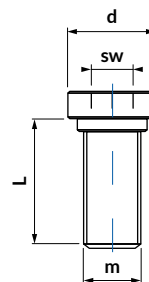

Referencia Reference n°	Montar con Assemble with	m	L	d	sw
BAR-S1016	BAR1600	M10	29	16,5	8
BAR-S1216		M12	29	16,5	8
BAR-S1220	BAR2000	M12	30	20,5	10
BAR-S1620		M16	34	20,5	10
BAR-S1624	BAR2500	M16	34	24,5	12
BAR-S1824		M18	38	24,5	12
BAR-S2024		M20	38	24,5	12
BAR-S2034	BAR5500*	M20	45	34	12
BAR-S2234		M22	49	34	12
BAR-S2434		M24	55	34	12

*Consultar departamento técnico para montaje con M30
*Please consult with our technical department for assembly with M30

Forma de pedido: BAR-S + m*a
How to order: BAR-T + m*a

TUERCA BAR-T
NUT BAR-T

STOCK

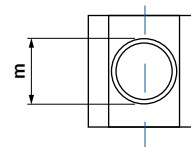
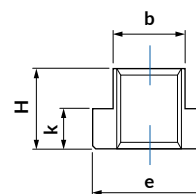
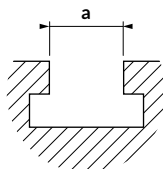

m	a	b	e	H	k
M10	12	11,7	18	14	7
M12	14	13,7	22	16	8
M12	16	15,7	25	18	9
M12	18	17,7	28	20	10
M16	18	17,7	28	20	10
M16	20	19,7	32	24	12
M16	22	21,7	35	28	14
M16	24	23,7	40	32	16
M16	28	27,7	44	36	18
M20	22	21,7	35	28	14
M20	24	23,7	40	32	16
M24	28	27,7	44	36	18
M24	36	35,6	54	44	22

Forma de pedido: BAR-T + m*a
How to order: BAR-T + m*a

BRIDAS DE AMARRE RÁPIDO COMBINED SLIDING CLAMP

Brida de amarre para moldes de inyección / Power Clamp For Injection Moulding
Fórmula de cálculo / Formula calculator:

$$\frac{M \times FG}{1000} = kN$$

$$\frac{kN}{\mu} = \text{Resultado} / \text{Result}$$

$$\frac{\text{Resultado}}{F_v} = \text{N}^\circ \text{ de bridas} / \text{Number of clamps}$$

$$\frac{2500 \text{ kg} \times 9,81}{1000} = 24,52 \text{ kN}$$

$$\frac{24,52}{0,14} = 175,14 \text{ kN}$$

$$\frac{175,14 \text{ kN}}{25 \text{ kN}} = 7 \text{ bridas} / \text{clamps}$$

 usar 8 bridas / use 8 clamps

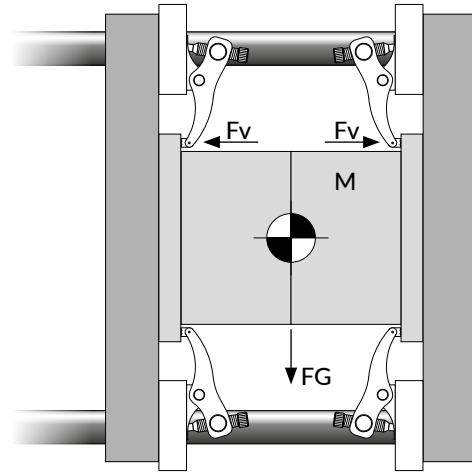

Brida de amarre para troquel de estampación / Power Clamp For Press Moulding
Fórmula de cálculo / Formula calculator:

$$\frac{M \times FG}{1000} = kN$$

$$\frac{kN}{\mu} = \text{Resultado} / \text{Result}$$

(60% molde superior, 40% inferior)

(60% for superior mold, 40% for inferior)

$$\frac{\text{Resultado Sup.}}{F_v} = \text{N}^\circ \text{ de bridas} / \text{Number of clamps}$$

$$\frac{\text{Resultado Inf.}}{F_v} = \text{N}^\circ \text{ de bridas} / \text{Number of clamps}$$

$$\frac{5000 \text{ kg} \times 9,81}{1000} = 49,050 \text{ kN}$$

$$\frac{49,050}{0,14} = 350,35 \text{ kN}$$

(210,21 sup., 140,14 inf.)

$$\frac{210,21 \text{ kN}}{25 \text{ kN}} = 8 \text{ bridas} / \text{clamps}$$

$$\frac{140,14 \text{ kN}}{25 \text{ kN}} = 5,6 \text{ bridas} / \text{clamps}$$

 usar 6 bridas / use 6 clamps

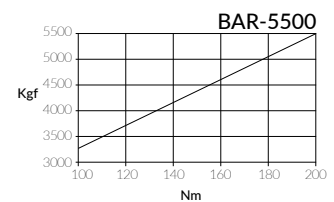
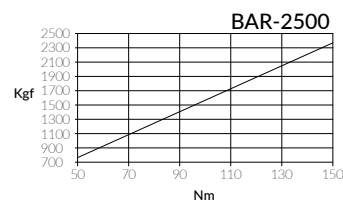
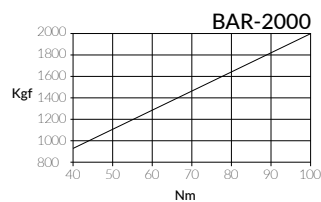
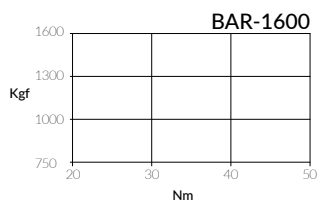
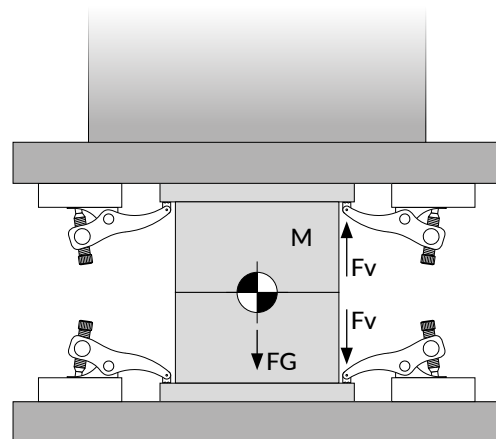

ARANDELA ARZ WASHER ARZ

Material: Acero zincado / Zinc plated steel
Dureza / Hardness : 100HV

STOCK

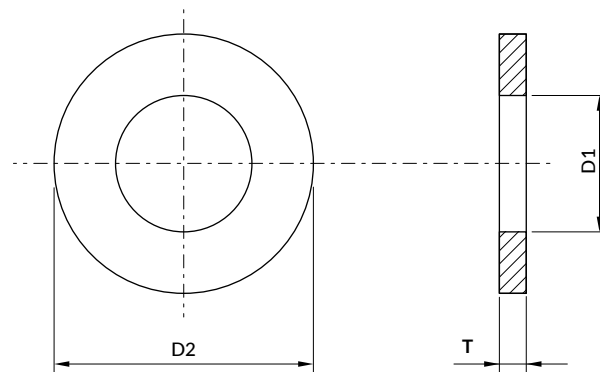

Norma / Standard: DIN 125

m	D1 min.	D2 max.	T
M3	3,2	7	0,5 (±0,05)
M4	4,3	9	0,8 (±0,1)
M5	5,3	10	1,0 (±0,1)
M6	6,4	12	1,6 (±0,2)
M8	8,4	16	1,6 (±0,2)
M10	10,5	20	2,0 (±0,2)
M12	13,0	24	2,5 (±0,2)
M14	15,0	28	2,5 (±0,3)
M16	17,0	30	3 (±0,3)
M18	19,0	34	3 (±0,3)
M20	21,0	37	3 (±0,3)
M22	23,0	39	3 (±0,3)
M24	25,0	44	4 (±0,3)
M27	28,0	50	4 (±0,3)
M30	31,0	56	4 (±0,3)
M33	34,0	60	5 (±0,6)
M36	37,0	66	5 (±0,6)
M39	40,0	72	6 (±1)
M42	43,0	78	7 (±1)
M45	46,0	85	7 (±1)
M48	50,0	92	8 (±1)

Forma de pedido: ARZ + m
How to order: ARZ + m

ARANDELA ARN WASHER ARN

Material: 1.7182 o equivalente zincado (Delta Protect) / Zinc plated 1.7182 or equivalent (Delta Protect)

STOCK

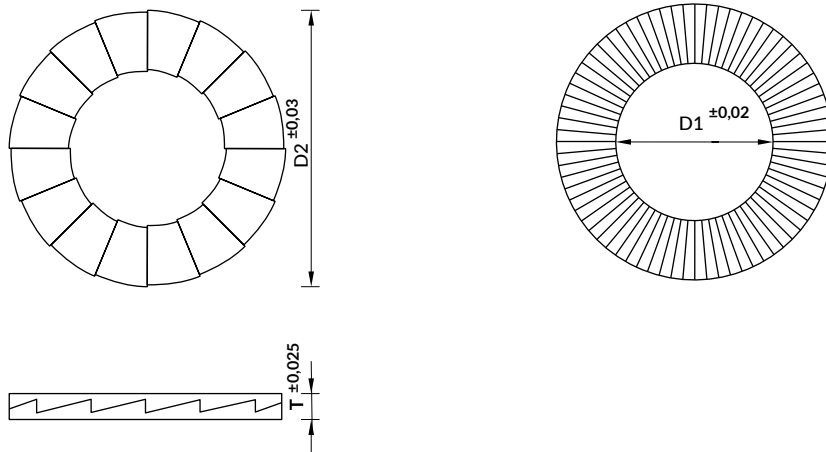

m	D1	D2	T
M3	3,4	7	1,7
M4	4,4	7,6	1,7
M5	5,4	9	1,7
M6	6,5	10,8	1,7
M8	8,6	13,5	2,7
M10	10,7	16,6	2,7
M12	13	19,5	2,7
M14	15,2	23	3,7
M16	17	25,4	3,7
M18	19,5	29	3,7
M20	21,4	30,7	3,7
M22	23,4	34,5	3,7
M24	25,3	39	3,7
M27	28,4	42	5,4
M30	31,4	47	5,7
M33	34,4	48,5	5,5
M36	37,4	55	6,2
M39	40,4	58,5	6,2
M42	43,2	63	6,3
M45	46,2	70	6,5
M48	49,6	75	6,5

Forma de pedido: ARN + m

How to order: ARN + m

TUERCA TRZ NUT TRZ

Material: Acero zincado calidad 8 / Zinc plated steel quality 8

STOCK

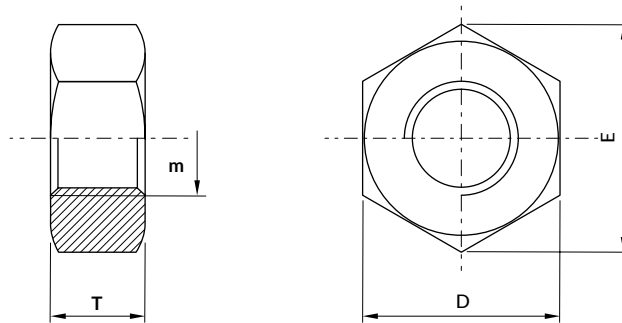

Norma / Standard: DIN 934

m	D	T	E min
M3	5,5	2,4	6,01
M4	7	3,2	7,66
M5	8	4	8,79
M6	10	5	11,05
M7	11	5,5	12,12
M8	13	6,5	14,38
M10	17	8	18,90
M12	19	10	21,10
M14	22	11	24,49
M16	24	13	26,75
M18	27	15	29,56
M20	30	16	32,95
M22	32	18	35,03
M24	36	19	39,55
M27	41	22	45,20
M30	46	24	50,85
M33	50	26	55,37
M36	55	29	60,79
M39	60	31	66,44
M42	65	34	72,09
M45	70	36	76,95
M48	75	38	82,60

Forma de pedido: TRZ + m
How to order: TRZ + m

TORNILLO TCO SCREW TCO

Material: Acero pavonado calidad 10.9 / Blued steel quality 10.9

STOCK

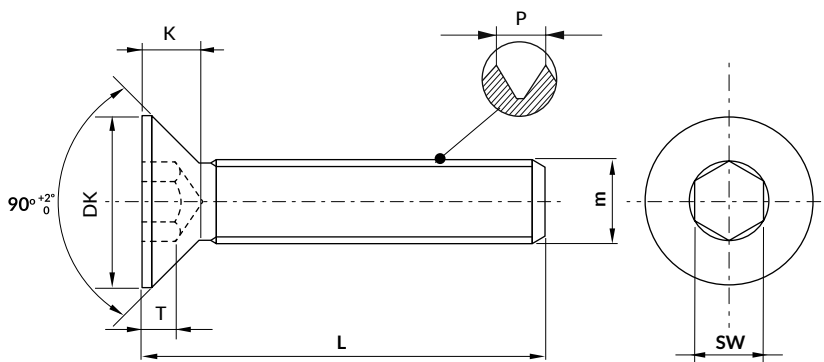

Norma / Standard: DIN 7991

	P	0,5	0,7	0,8	1	1,25	1,5	1,75	2	2	2,5	2,5	3
SW	2	2,5	3	4	5	6	8	10	10	12	12	14	14
DK	6	8	10	12	16	20	24	27	30	33	36	39	39
K _{max}	1,86	2,48	3,1	3,72	4,96	6,2	7,44	8,4	8,8	9,3	10,16	14	14
T _{min}	1,1	1,5	1,9	2,2	3	3,6	4,3	4,5	4,8	5,2	5,6	10	10
m	M3	M4	M5	M6	M8	M10	M12	M14	M16	M18	M20	M24	
L													
6	•	•	-	-	-	-	-	-	-	-	-	-	-
8	•	•	•	•	-	-	-	-	-	-	-	-	-
10	•	•	•	•	•	-	-	-	-	-	-	-	-
12	•	•	•	•	•	•	-	-	-	-	-	-	-
14	•	•	•	•	•	•	•	-	-	-	-	-	-
16	•	•	•	•	•	•	•	-	-	-	-	-	-
18	•	•	•	•	•	•	•	-	-	-	-	-	-
20	•	•	•	•	•	•	•	•	-	-	-	-	-
22	•	•	•	•	•	•	•	-	-	-	-	-	-
25	•	•	•	•	•	•	•	•	•	-	-	-	-
30	•	•	•	•	•	•	•	•	•	•	-	-	-
35	-	•	•	•	•	•	•	•	•	•	•	-	-
40	-	•	•	•	•	•	•	•	•	•	•	•	-
45	-	•	•	•	•	•	•	•	•	•	•	•	-
50	-	•	•	•	•	•	•	•	•	•	•	•	•
55	-	•	•	•	•	•	•	•	•	•	•	•	•
60	-	•	•	•	•	•	•	•	•	•	•	•	•
65	-	-	•	•	•	•	•	•	•	•	•	•	•
70	-	-	•	•	•	•	•	•	•	•	•	•	•
80	-	-	-	•	•	•	•	•	•	•	•	•	•
90	-	-	-	•	•	•	•	•	•	•	•	•	•
100	-	-	-	•	•	•	•	•	•	•	•	•	•
110	-	-	-	•	•	•	•	•	•	•	•	•	•
120	-	-	-	•	•	•	•	•	•	•	•	•	•
130	-	-	-	-	•	•	•	•	•	•	•	•	•
140	-	-	-	-	•	•	•	•	•	•	•	•	•
150	-	-	-	-	•	•	•	•	•	•	•	•	•
160	-	-	-	-	•	•	•	•	•	•	•	•	•

Forma de pedido: TCO + m*L
How to order: TCO + m*L

TORNILLO TCC
SCREW TCC

Material: Acero pavonado calidad 12.9 / Blued steel quality 12.9

STOCK

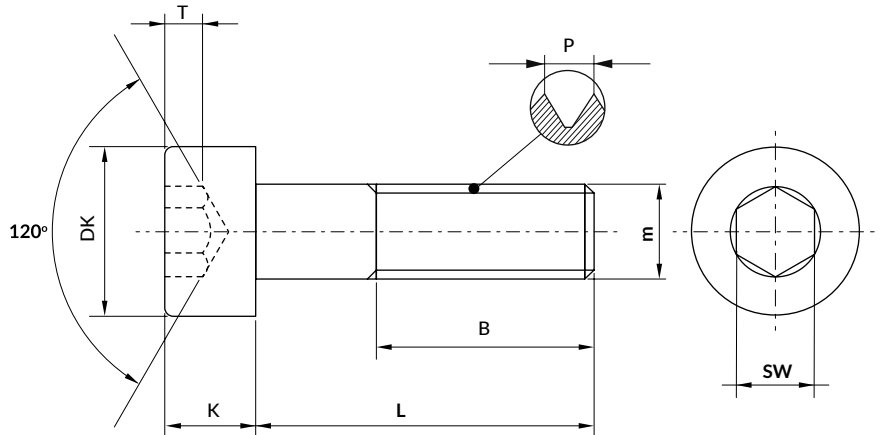

Norma / Standard: DIN 912

	0,5	0,7	0,8	1	1,25	1,5	1,75	2	2	2,5	2,5	2,5	3	3	3,5	3,5	4	4	4,5	4,5	5
P	0,5	0,7	0,8	1	1,25	1,5	1,75	2	2	2,5	2,5	2,5	3	3	3,5	3,5	4	4	4,5	4,5	5
SW	2,5	3	4	5	6	8	10	12	14	14	17	17	19	19	22	24	27	27	32	32	36
DK	5,5	7	8,5	10	13	16	18	21	24	27	30	33	36	40	45	50	54	58	63	68	72
K _{max}	3	4	5	6	8	10	12	14	16	18	20	22	24	27	30	33	36	39	42	45	48
T _{min}	1,3	2	2,5	3	4	5	6	7	8	9	10	11	12	13,5	15,5	18	19	21	24	26	28
B	18	20	22	24	28	32	36	40	44	48	52	56	60	66	72	78	84	90	96	100	108
m	M3	M4	M5	M6	M8	M10	M12	M14	M16	M18	M20	M22	M24	M27	M30	M33	M36	M39	M42	M45	M48
L																					
6	•	•	-	-	-	-	-	-	-	-	-	-	-	-	-	-	-	-	-	-	-
8	•	•	•	•	-	-	-	-	-	-	-	-	-	-	-	-	-	-	-	-	-
10	•	•	•	•	•	-	-	-	-	-	-	-	-	-	-	-	-	-	-	-	-
12	•	•	•	•	•	-	-	-	-	-	-	-	-	-	-	-	-	-	-	-	-
14	•	•	•	•	•	-	-	-	-	-	-	-	-	-	-	-	-	-	-	-	-
16	•	•	•	•	•	•	-	-	-	-	-	-	-	-	-	-	-	-	-	-	-
18	•	•	•	•	•	•	-	-	-	-	-	-	-	-	-	-	-	-	-	-	-
20	•	•	•	•	•	•	-	-	-	-	-	-	-	-	-	-	-	-	-	-	-
22	•	•	•	•	•	•	•	-	-	-	-	-	-	-	-	-	-	-	-	-	-
25	•	•	•	•	•	•	•	-	-	-	-	-	-	-	-	-	-	-	-	-	-
30	•	•	•	•	•	•	•	•	-	-	-	-	-	-	-	-	-	-	-	-	-
35	•	•	•	•	•	•	•	•	•	-	-	-	-	-	-	-	-	-	-	-	-
40	•	•	•	•	•	•	•	•	•	•	-	-	-	-	-	-	-	-	-	-	-
45	•	•	•	•	•	•	•	•	•	•	•	-	-	-	-	-	-	-	-	-	-
50	•	•	•	•	•	•	•	•	•	•	•	•	-	-	-	-	-	-	-	-	-
55	-	•	•	•	•	•	•	•	•	•	•	•	•	-	-	-	-	-	-	-	-
60	-	•	•	•	•	•	•	•	•	•	•	•	•	•	-	-	-	-	-	-	-
65	-	-	•	•	•	•	•	•	•	•	•	•	•	•	•	-	-	-	-	-	-
70	-	•	•	•	•	•	•	•	•	•	•	•	•	•	•	•	-	-	-	-	-
75	-	-	•	•	•	•	•	•	•	•	•	•	•	•	•	•	-	-	-	-	-
80	-	-	•	•	•	•	•	•	•	•	•	•	•	•	•	•	•	-	-	-	-
85	-	-	•	•	•	•	•	•	•	•	•	•	•	•	•	•	•	•	-	-	-
90	-	-	•	•	•	•	•	•	•	•	•	•	•	•	•	•	•	•	•	-	-
95	-	-	•	•	•	•	•	•	•	•	•	•	•	•	•	•	•	•	•	•	-
100	-	-	•	•	•	•	•	•	•	•	•	•	•	•	•	•	•	•	•	•	•
110	-	-	-	•	•	•	•	•	•	•	•	•	•	•	•	•	•	•	•	•	•
120	-	-	-	•	•	•	•	•	•	•	•	•	•	•	•	•	•	•	•	•	•
130	-	-	-	-	•	•	•	•	•	•	•	•	•	•	•	•	•	•	•	•	•
140	-	-	-	-	•	•	•	•	•	•	•	•	•	•	•	•	•	•	•	•	•
150	-	-	-	-	•	•	•	•	•	•	•	•	•	•	•	•	•	•	•	•	•
160	-	-	-	-	•	•	•	•	•	•	•	•	•	•	•	•	•	•	•	•	•
170	-	-	-	-	•	•	•	•	•	•	•	•	•	•	•	•	•	•	•	•	•
180	-	-	-	-	•	•	•	•	•	•	•	•	•	•	•	•	•	•	•	•	•
190	-	-	-	-	•	•	•	•	•	•	•	•	•	•	•	•	•	•	•	•	•
200	-	-	-	-	•	•	•	•	•	•	•	•	•	•	•	•	•	•	•	•	•
210	-	-	-	-	•	•	•	•	•	•	•	•	•	•	•	•	•	•	•	•	•
220	-	-	-	-	•	•	•	•	•	•	•	•	•	•	•	•	•	•	•	•	•
230	-	-	-	-	•	•	•	•	•	•	•	•	•	•	•	•	•	•	•	•	•
240	-	-	-	-	•	•	•	•	•	•	•	•	•	•	•	•	•	•	•	•	•
250	-	-	-	-	•	•	•	•	•	•	•	•	•	•	•	•	•	•	•	•	•
260	-	-	-	-	•	•	•	•	•	•	•	•	•	•	•	•	•	•	•	•	•
270	-	-	-	-	•	•	•	•	•	•	•	•	•	•	•	•	•	•	•	•	•
280	-	-	-	-	•	•	•	•	•	•	•	•	•	•	•	•	•	•	•	•	•
290	-	-	-	-	•	•	•	•	•	•	•	•	•	•	•	•	•	•	•	•	•
300	-	-	-	-	•	•	•	•	•	•	•	•	•	•	•	•	•	•	•	•	•

Forma de pedido: TCC + m*L
How to order: TCC + m*L

TORNILLO TOPE GUÍA TT SHOULDER SCREW TT

Material: Acero 12.9 / Steel 12.9
Dureza / Hardness: 37-43 HRC

STOCK

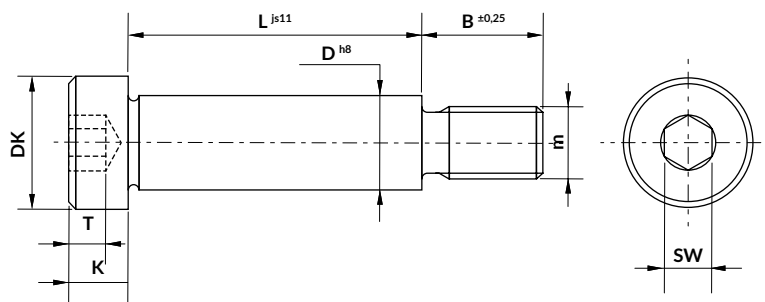

Norma / Standard: ISO 7379

	2,5	3	4	5	6	8	10	12
SW	2,5	3	4	5	6	8	10	12
DK	8	10	13	16	18	24	30	36
K	4	4,5	5,5	7	9	11	14	16
T _{min}	5	6	8	10	12	16	20	24
D	5	6	8	10	12	16	20	24
B	8	9,5	11	13	16	18	22	27
m	M4	M5	M6	M8	M10	M12	M16	M20
L								
10	•	•	•	•	-	-	-	-
12	•	•	•	•	-	-	-	-
15	•	•	•	•	•	-	-	-
16	•	•	•	•	•	-	-	-
20	•	•	•	•	•	-	-	-
25	•	•	•	•	•	•	-	-
30	•	•	•	•	•	•	•	-
35	•	•	•	•	•	•	•	-
40	•	•	•	•	•	•	•	•
45	•	•	•	•	•	•	•	•
50	•	•	•	•	•	•	•	•
55	-	•	•	•	•	•	•	•
60	-	•	•	•	•	•	•	•
65	-	•	•	•	•	•	•	•
70	-	•	•	•	•	•	•	•
80	-	•	•	•	•	•	•	•
90	-	-	•	•	•	•	•	•
100	-	-	•	•	•	•	•	•
110	-	-	-	•	•	•	•	•
120	-	-	-	•	•	•	•	•
140	-	-	-	-	•	•	•	•
160	-	-	-	-	-	•	•	•
200	-	-	-	-	-	•	•	•

Forma de pedido: TT + m*L
How to order: TT + m*L

TORNILLO TOPE GUÍA TL SHOULDER SCREW TL

Material: Acero 12.9 / Steel 12.9
Dureza / Hardness: 37-43 HRC

STOCK

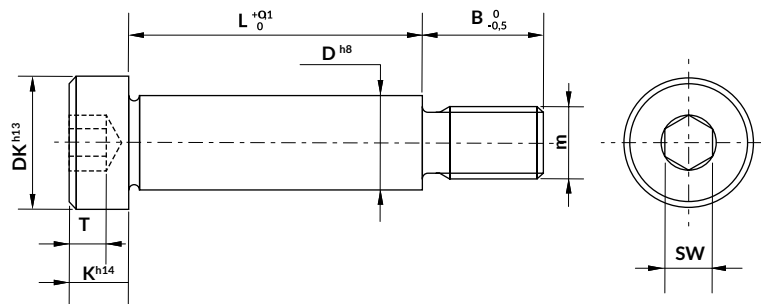

SW	2	2,5	3	4	5	6	8	10	14	17
DK	6	7	9	11	14	18	22	28	36	45
K	2,5	3,5	4	5	6	8	10	12	16	20
T	1,5	2	2,5	3	4	5	6	8	11	12
D	4	5	6	8	10	12	16	20	25	32
B	6	7	8	10	12	16	20	25	32	40
m	M3	M4	M5	M6	M8	M10	M12	M16	M20	M24
L										
6	•	•	•	•	•	-	-	-	-	-
8	•	•	•	•	•	•	-	-	-	-
10	•	•	•	•	•	•	•	-	-	-
12	•	•	•	•	•	•	•	-	-	-
14	•	•	•	•	•	•	•	-	-	-
16	•	•	•	•	•	•	•	•	-	-
20	•	•	•	•	•	•	•	•	•	-
25	•	•	•	•	•	•	•	•	•	•
30	•	•	•	•	•	•	•	•	•	•
32	•	•	•	•	•	•	•	•	•	•
40	•	•	•	•	•	•	•	•	•	•
50	-	-	•	•	•	•	•	•	•	•
60	-	-	•	•	•	•	•	•	•	•
63	-	-	•	•	•	•	•	•	•	•
70	-	-	-	•	•	•	•	•	•	•
80	-	-	-	•	•	•	•	•	•	•
90	-	-	-	•	•	•	•	•	•	•
100	-	-	-	•	•	•	•	•	•	•
110	-	-	-	•	•	•	•	•	•	•
120	-	-	-	-	•	•	•	•	•	•
125	-	-	-	-	•	•	•	•	•	•
140	-	-	-	-	•	•	•	•	•	•
160	-	-	-	-	•	•	•	•	•	•
200	-	-	-	-	-	•	•	•	•	•
250	-	-	-	-	-	-	•	•	•	•

Forma de pedido: TL + m*L
How to order: TL + m*L

TORNILLO LIMITADOR SVC LIMITING SCREW SVC

Material:

- Arandela: acero templado, resistencia de 100kg / mm²
- Washer: hardened steel, tensile strength 100kg/mm²
- Casquillo: acero templado, resistencia de 120-140 kg / mm²
- Spacer: hardened steel; strength 120-140 kg/mm²
- Tornillo DIN 912: acero 12.9
- DIN 912 Screw: steel 12.9

STOCK

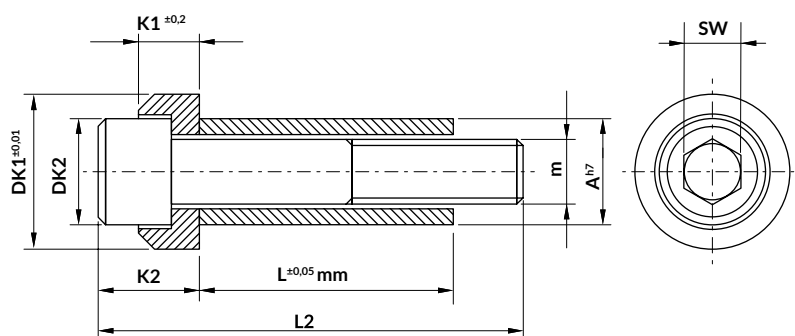

SW	5	6	8	10	14
DK1	15	19	23	27	34
DK2 max.	10	13	16	18	24
K1	5,5	6,5	7,5	9,0	11,0
K2	10,0	13,0	15,0	18,0	24,0
A	10,0	12,5	15,0	17,5	23,0
m	M6	M8	M10	M12	M16
L			(L2)		
15	30	-	-	-	-
20	35	35	40	-	-
25	40	40	45	-	-
30	45	45	50	50	-
35	50	50	55	60	-
40	55	55	60	60	70
45	60	60	65	65	75
50	65	65	70	70	80
55	70	70	75	80	90
60	80	80	80	90	90
65	80	80	85	90	100
70	90	90	90	100	100
80	100	100	100	110	110
90	110	110	110	120	120
100	120	120	120	130	130
110	130	130	130	140	140
120	-	140	140	150	150
140	-	160	160	180	180
150	-	-	170	180	180
160	-	-	180	200	200
180	-	-	200	220	210
200	-	-	220	240	240
220	-	-	-	260	250
230	-	-	-	-	260

Forma de pedido: SVC + m*L
How to order: SVC + m*L

PASADOR CILÍNDRICO PC CYLINDRICAL DOWEL PIN PC

Material: Acero 1.3505 / Steel 1.3505
Dureza / Hardness: 60-62 HRC

STOCK

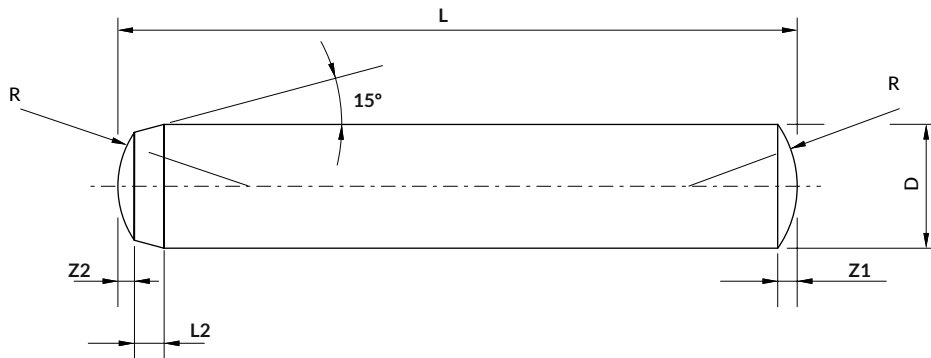

Norma / Standard: DIN 6325

L2	0,4	0,5	0,6	0,7	0,8	1	1,2	1,5	1,8	2	2,5	2,5	2,5	3	4	4
R	1	1,6	2	2,5	3	4	5	6	8	10	12	13	16	16	20	25
Z1	0,15	0,23	0,3	0,4	0,45	0,6	0,75	0,9	1,2	1,5	1,8	1,8	2	2,5	2	4
Z2	0,08	0,12	0,18	0,25	0,3	0,4	0,5	0,6	0,8	1	1,3	1,3	1,3	1,7	2	2,5
D ^{m6}	1	1,5	2	2,5	3	4	5	6	8	10	12	13	14	16	20	25
L																
2	-	-	-	-	-	-	-	-	-	-	-	-	-	-	-	-
3	-	-	-	-	-	-	-	-	-	-	-	-	-	-	-	-
4	•	•	•	•	•	•	•	•	•	•	•	•	•	•	•	•
5	•	•	•	•	•	•	•	•	•	•	•	•	•	•	•	•
6	•	•	•	•	•	•	•	•	•	•	•	•	•	•	•	•
8	•	•	•	•	•	•	•	•	•	•	•	•	•	•	•	•
10	•	•	•	•	•	•	•	•	•	•	•	•	•	•	•	•
12	•	•	•	•	•	•	•	•	•	•	•	•	•	•	•	•
14	-	•	•	•	•	•	•	•	•	•	•	•	•	•	•	•
16	•	•	•	•	•	•	•	•	•	•	•	•	•	•	•	•
18	-	•	•	•	•	•	•	•	•	•	•	•	•	•	•	•
20	-	•	•	•	•	•	•	•	•	•	•	•	•	•	•	•
22	-	•	•	•	•	•	•	•	•	•	•	•	•	•	•	•
24	-	•	•	•	•	•	•	•	•	•	•	•	•	•	•	•
26	-	-	•	•	•	•	•	•	•	•	•	•	•	•	•	•
28	-	-	•	•	•	•	•	•	•	•	•	•	•	•	•	•
30	-	-	•	•	•	•	•	•	•	•	•	•	•	•	•	•
32	-	-	•	•	•	•	•	•	•	•	•	•	•	•	•	•
36	-	-	•	•	•	•	•	•	•	•	•	•	•	•	•	•
40	-	-	•	•	•	•	•	•	•	•	•	•	•	•	•	•
45	-	-	-	•	•	•	•	•	•	•	•	•	•	•	•	•
50	-	-	•	•	•	•	•	•	•	•	•	•	•	•	•	•
55	-	-	-	•	•	•	•	•	•	•	•	•	•	•	•	•
60	-	-	-	•	•	•	•	•	•	•	•	•	•	•	•	•
70	-	-	-	•	•	•	•	•	•	•	•	•	•	•	•	•
80	-	-	-	•	•	•	•	•	•	•	•	•	•	•	•	•
90	-	-	-	•	•	•	•	•	•	•	•	•	•	•	•	•
100	-	-	-	•	•	•	•	•	•	•	•	•	•	•	•	•
120	-	-	-	•	•	•	•	•	•	•	•	•	•	•	•	•
130	-	-	-	•	•	•	•	•	•	•	•	•	•	•	•	•
140	-	-	-	•	•	•	•	•	•	•	•	•	•	•	•	•
150	-	-	-	•	•	•	•	•	•	•	•	•	•	•	•	•

Forma de pedido: PC + D*L
How to order: PC + D*L

PASADOR CILÍNDRICO ROSCADO PRN CYLINDRICAL DOWEL PIN WITH THREAD PRN

Material: Acero 1.3505 / Steel 1.3505

Dureza / Hardness: 60-62 HRC

STOCK

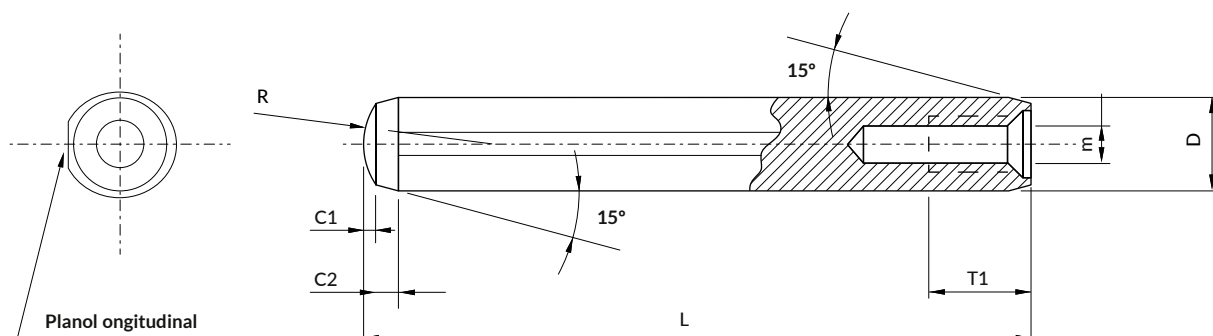

Norma / Standard: DIN 7979

C1	0,4	0,4	0,54	0,6	0,8	1	1,2	1,2	1,4	1,6	2	2,5	3
C2	1,3	1,3	1,7	2,1	2,6	3	3,8	3,8	4	4,7	6	6	7
m	M2	M3	M3	M4	M5	M6	M6	M6	M8	M8	M10	M16	M20
T1	4-5,5	4,5-6	4,5-6	6	8	10	10	13	12	12	16	24	30
D ^{m6}	3	4	5	6	8	10	12	13	14	16	20	25	30
L													
8	-	-	•	-	-	-	-	-	-	-	-	-	-
10	•	•	•	•	-	-	-	-	-	-	-	-	-
12	•	•	•	•	-	-	-	-	-	-	-	-	-
14	•	•	•	•	-	-	-	-	-	-	-	-	-
16	•	•	•	•	•	•	-	-	-	-	-	-	-
18	•	•	•	•	•	-	-	-	-	-	-	-	-
20	•	•	•	•	•	•	•	-	-	-	-	-	-
22	-	-	-	•	•	-	-	-	-	-	-	-	-
24	-	•	•	•	•	•	•	-	-	-	-	-	-
26	-	-	•	•	•	-	-	-	-	-	-	-	-
28	-	•	•	•	•	•	•	-	•	•	-	-	-
30	-	•	•	•	•	•	•	-	•	•	•	-	-
32	-	•	•	•	•	•	•	-	•	•	•	•	-
36	-	•	•	•	•	•	•	-	•	•	•	•	-
40	-	•	•	•	•	•	•	-	•	•	•	•	-
45	-	•	•	•	•	•	•	-	•	•	•	•	-
50	-	•	•	•	•	•	•	-	•	•	•	•	•
55	-	-	•	•	•	•	•	-	•	•	•	•	•
60	-	•	•	•	•	•	•	-	•	•	•	•	•
65	-	-	-	-	-	-	-	-	•	•	-	-	-
70	-	-	-	•	•	•	•	-	•	•	•	•	•
80	-	-	-	•	•	•	•	-	•	•	•	•	•
90	-	-	-	•	•	•	•	-	•	•	•	•	•
100	-	-	-	•	•	•	•	-	•	•	•	•	•
110	-	-	-	-	-	•	-	-	-	-	-	-	-
120	-	-	-	-	•	•	•	-	•	•	•	•	•
130	-	-	-	-	-	-	-	-	•	•	•	-	-
140	-	-	-	-	-	-	-	-	•	•	•	-	-
150	-	-	-	-	-	-	-	-	•	•	•	-	-

Forma de pedido: PRN + D*L
How to order: PRN + D*L

PASADOR ANTIGRIPANTE PRS ANTI-SEIZE DOWEL PIN PRS

Material: acero 1.3505 con tratamiento antigripante / 1.3505 steel with anti-seize treatment

! El tratamiento antigripante puede alterar levemente la tolerancia y la dureza con respecto al pasador PRN
Anti-seize treatment may slightly alter tolerance and toughness compared to PRN dowel pin

STOCK

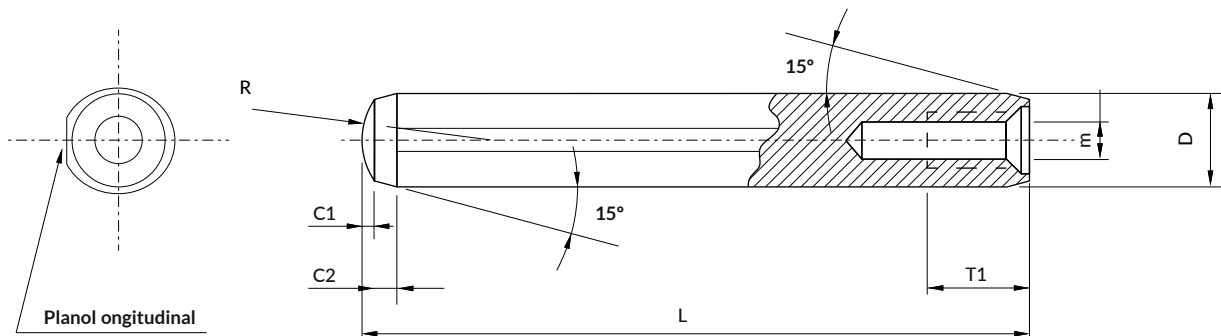

C1	0,4	0,4	0,5	0,6	0,8	1	1,2	1,4	1,6	2
C2	1,3	1,3	1,7	2,1	2,6	3	3,8	4	4,7	6
m	M2	M3	M3	M4	M5	M6	M6	M8	M8	M10
T1	4-5,5	4,5-6	4,5-6	6	8	10	10	12	12	16
D	3	4	5	6	8	10	12	14	16	20
L										
8	-	-	•	-	-	-	-	-	-	-
10	-	•	•	-	-	-	-	-	-	-
12	-	•	•	•	-	-	-	-	-	-
14	-	•	•	•	-	-	-	-	-	-
16	-	•	•	•	•	•	-	-	-	-
18	-	•	•	•	•	-	-	-	-	-
20	-	•	•	•	•	-	-	-	-	-
22	-	-	-	•	•	-	-	-	-	-
24	-	•	•	•	•	•	•	-	-	-
26	-	-	-	•	•	-	-	-	-	-
28	-	•	•	•	•	-	-	•	-	-
30	-	•	•	•	•	•	•	-	•	-
32	-	•	•	•	•	•	•	•	•	•
36	-	•	•	•	•	•	•	•	•	•
40	-	•	•	•	•	•	•	•	•	•
45	-	•	•	•	•	•	•	•	•	•
50	-	•	•	•	•	•	•	•	•	•
55	-	-	•	•	•	•	•	•	•	•
60	-	•	•	•	•	•	•	•	•	•
65	-	-	-	-	-	-	-	-	•	-
70	-	-	•	•	•	•	•	•	•	•
80	-	-	-	•	•	•	•	•	•	•
90	-	-	-	•	•	•	•	•	•	•
100	-	-	-	•	•	•	•	•	•	•
120	-	-	-	-	•	•	•	•	•	•
130	-	-	-	-	-	-	-	-	•	•
140	-	-	-	-	-	-	-	-	•	•
150	-	-	-	-	-	-	-	-	•	•

Forma de pedido: PRS + D*L
How to order: PRS + D*L

CASQUILLO DE RETENCIÓN PARA PASADOR CRP DOWEL PIN RETAINING SLEEVE CRP

STOCK

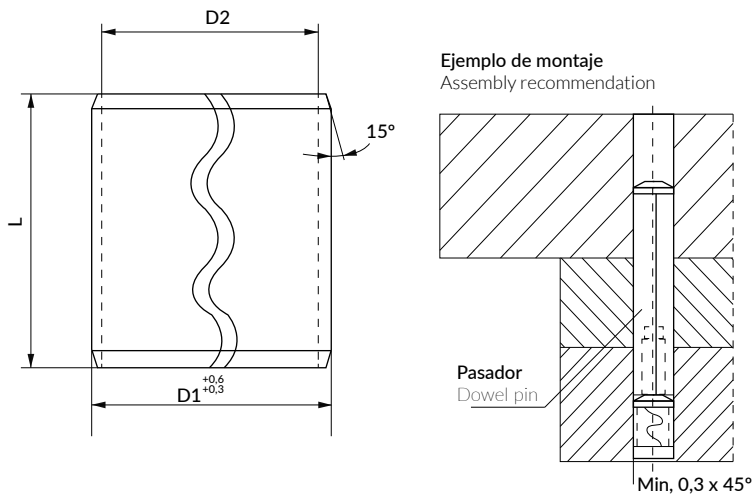

Su función es posicionar el pasador en el nivel deseado dentro del agujero, o bien retener el pasador evitando su extracción.
It is used for positioning dowel pins at the desired level in hole, or as a dowel pin stopper preventing extraction.

D1	D2	L	Fuerza de extracción / Pull-out Strength (N)
6	4,4	6	392
8	5,6	8	1373
10	6,4	12	2354
12	8	12	1765
16	11	12	1422

Forma de pedido: CRP + D1

How to order: CRP + D1

HERRAMIENTA PARA EXTRACCIÓN DE PASADORES HECM

DOWEL PIN EXTRACTOR HECM

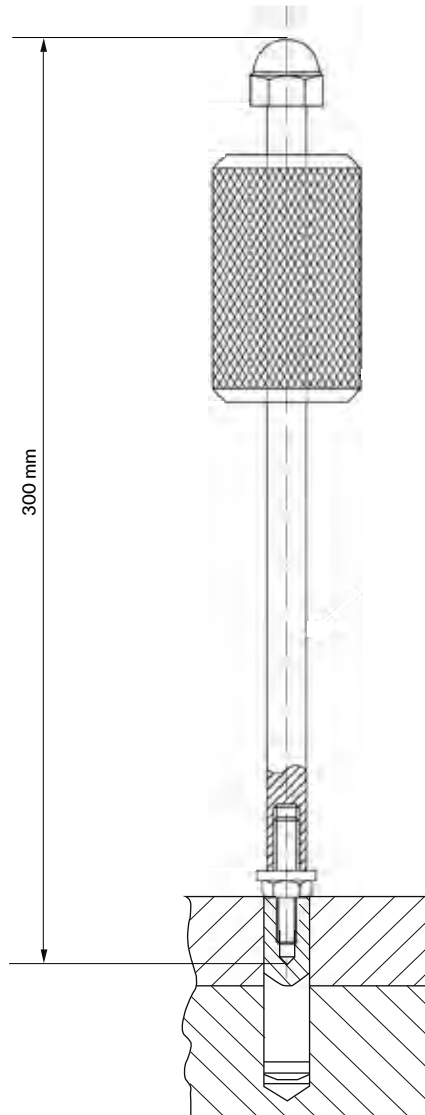

i Rosca de extracción de M3 a M10.
Extraction threads from M3 to M10.

BASE MAGNÉTICA ALTA BM1AL HIGH MAGNETIC BASE BM1AL

Conjunto de imanes y bases magnéticas construidos en aleación ALNICO, con la capacidad máxima de resistencia a la temperatura.
Set of magnets and magnetic bases built in ALNICO alloy, with the maximum capacity of temperature resistance.

STOCK

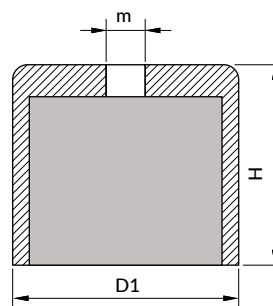

T max de trabajo Máx. working temperature	D1	H	m	Peso / Weight (g)	F* (Kg max.)
400°C	9,5	15	M3	-	1,2
	17,5	16	M6	23	2,75
	20,5	19	M6	40	4,15
	27	25	M6	85	6,8
	35	30	M6	184	14,75
	50	40	M8	470	50

Forma de pedido: BM1AL + D1
How to order: BM1AL + D1

BASE MAGNÉTICA BAJA BM2AL LOW MAGNETIC BASE BM2AL

Conjunto de imanes y bases magnéticas construidos en aleación ALNICO, con la capacidad máxima de resistencia a la temperatura.
Set of magnets and magnetic bases built in ALNICO alloy, with the maximum capacity of temperature resistance.

STOCK

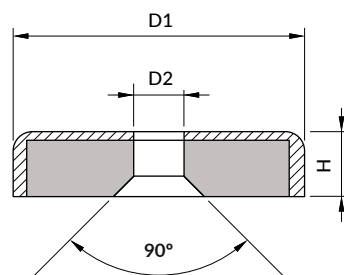

T max de trabajo Máx. working temperature	D1	H	D2	Peso / Weight (g)	F* (Kg max.)
400°C	19	8	3,5	13	3,5
	28,6	9	4,75	36	5
	38	10,5	4,75	80	13

Forma de pedido: BM2AL + D1
How to order: BM2AL + D1

IMÁN REDONDO IM1AL
ROUND MAGNET IM1AL

Conjunto de imanes y bases magneticas construidos en aleación ALNICO, con la capacidad máxima de resistencia a la temperatura.
Set of magnets and magnetic bases built in ALNICO alloy, with the maximum capacity of temperature resistance.

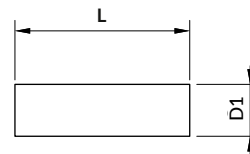

T max de trabajo Máx. working temperature	D1	L	Peso / Weight (g)	F* (Kg max.)
450°C	6	20	8,2	0,5
	8	25	18,4	0,8
	10	30	33,88	1,1

Forma de pedido: IM1AL + D1
How to order: IM1AL + D1

IMÁN RECTANGULAR IM2AL
RECTANGULAR MAGNET IM2AL

Conjunto de imanes y bases magneticas construidos en aleación ALNICO, con la capacidad máxima de resistencia a la temperatura.
Set of magnets and magnetic bases built in ALNICO alloy, with the maximum capacity of temperature resistance.

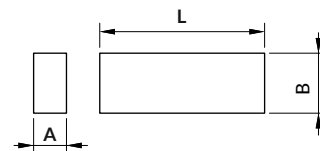

T max de trabajo Máx. working temperature	A	B	L	Peso / Weight (g)	F* (Kg max.)
450°C	5	10	20	7	0,6
	5	12,5	40	17,5	1,5
	5	15	60	31,5	2
	10	15	50	52,5	1,4
	10	15	75	56,25	1,4

Forma de pedido: IM2AL + A*L
How to order: IM2AL + A*L

IMÁN BOTÓN IM3AL BUTTON MAGNET IM3AL

Conjunto de imanes y bases magnéticas construidos en aleación ALNICO, con la capacidad máxima de resistencia a la temperatura.
Set of magnets and magnetic bases built in ALNICO alloy, with the maximum capacity of temperature resistance.

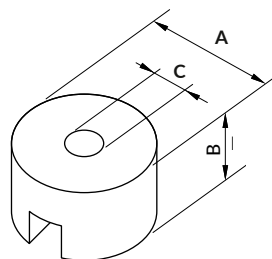

T max de trabajo Máx. working temperature	A	B	C	Peso / Weight (g)	F* (Kg max.)
450°C	12,5	9,5	4,5	6	0,7
	19	12,5	5	20	1,9
	25,5	16	5	50	3,6
	31,5	25,5	6,5	113	4,8

Forma de pedido: IM3AL + A
How to order: IM3AL + A

IMÁN DISCO NEODIMIO IM4ND NEODYMIUM DISC MAGNET IM4ND

La temperatura y la corrosión son factores que limitan el uso de los imanes de Neodimio.
Temperature and corrosion are factors that limit the use of Neodymium magnets.

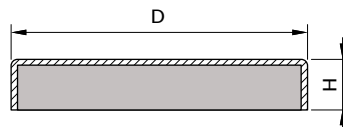

H Espesor mm / H Thickness mm	D Diámetro mm / D Diameter mm																								
	1,5	2	3	4	5	6	7	8	10	12	14	15	16	18	20	22	25	28	30	32	40	45	50	60	
1,5	-	-	•	•	•	-	-	-	•	-	-	-	-	-	-	-	-	-	-	-	-	-	-	-	-
2	-	•	-	•	•	•	•	•	•	-	-	-	-	•	•	-	-	-	-	-	-	-	-	-	-
3	•	-	•	•	•	•	•	•	•	-	-	•	-	-	•	•	-	-	-	-	-	-	-	-	-
4	-	-	•	•	•	•	-	•	•	-	•	-	-	•	-	-	-	-	-	-	-	-	-	-	-
5	-	-	•	•	•	•	-	•	•	-	•	-	•	•	•	-	•	-	•	•	•	-	•	•	•
6	-	•	•	-	-	-	-	-	-	-	-	-	-	-	-	-	-	-	-	-	-	-	-	-	-
7	-	-	-	-	-	-	-	-	-	-	-	-	-	-	-	-	•	-	-	-	-	-	-	-	-
7,5	-	-	-	-	-	•	-	•	-	-	-	-	-	-	-	-	-	-	-	-	-	-	-	-	-
8	-	-	-	•	•	-	-	-	-	-	-	-	-	-	-	-	-	-	-	-	-	-	-	-	-
10	-	-	•	•	•	-	-	•	•	-	-	•	-	-	•	•	•	•	•	•	-	-	•	-	-
15	-	-	-	-	-	-	-	-	-	-	-	-	-	-	-	-	-	-	-	•	-	-	-	-	-

Forma de pedido: IM4ND + D*H
How to order: IM4ND + D*H

BASE ALTA SANDWICH LISA BM3_
HIGH PLAIN SANDWICH BASE BM3_

Ajustables en altura
Adjustable height

BM3SC

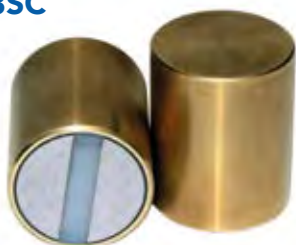

Material: Samario Cobalto / Cobalt Samarium

BM3ND



Material: Neodimio / Neodymium

STOCK

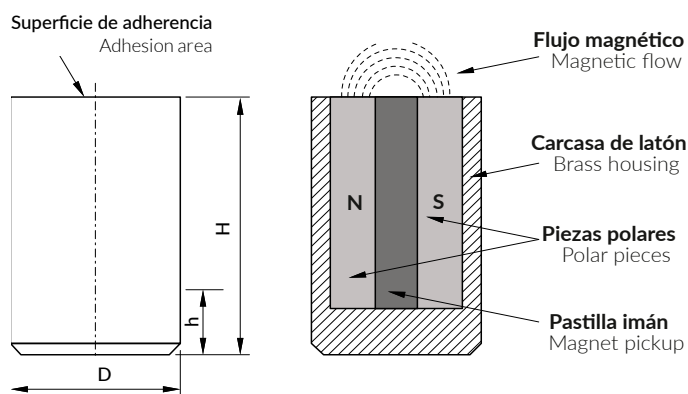

Material	T max de trabajo Máx. working temperature	D h6 (mm)	H (mm)	h* (mm)	Fuerza / Force (kg)	Peso / Weight (g)	Separación** Separation (mm)
NEODIMIO ND	80°C	6	20	10	1	4,5	1,5
		8	20	10	2,5	8	1,5
		10	20	8	4,5	12,5	2
		13	20	6	7	20	2,5
		16	20	2	15	30	3
		20	25	5	28	59	4
		25	35	7	45	132	5
SAMARIO COBALTO SC	200°C	32	40	4,5	70	245	6
		6	20	10	0,8	4,5	1,5
		8	20	10	2,2	8	1,5
		10	20	8	4	12,5	2
		13	20	6	6	20	2,5
		16	20	2	12,5	32	3
		20	25	5	25	60	4
25	35	7	40	134	5		
		32	40	4,5	60	251	6

*La cota h indica la medida en que se puede reducir la altura H sin perjudicar en absoluto su fuerza de adherencia. La superficie de adherencia no se puede rebajar más de 2 mm.

*The h parameter indicates the extent to which the height H can be reduced without impairing its adhesion strength. The adhesion surface can not be reduced by more than 2 mm.

**Separación mínima entre la carcasa exterior de la base y el hierro, para no disminuir su fuerza de atracción en caso de embutir la misma.

**Minimum separation between the outer casing base and iron, not to decrease its attraction in case of embedding it.

Forma de pedido / How to order: BM3SC + D
BM3ND + D

BASE ALTA SANDWICH CON AGUJERO DE ROSCADO BM3NDH HIGH SANDWICH BASE WITH THREAD BM3NDH

Ajustables en altura
Adjustable height

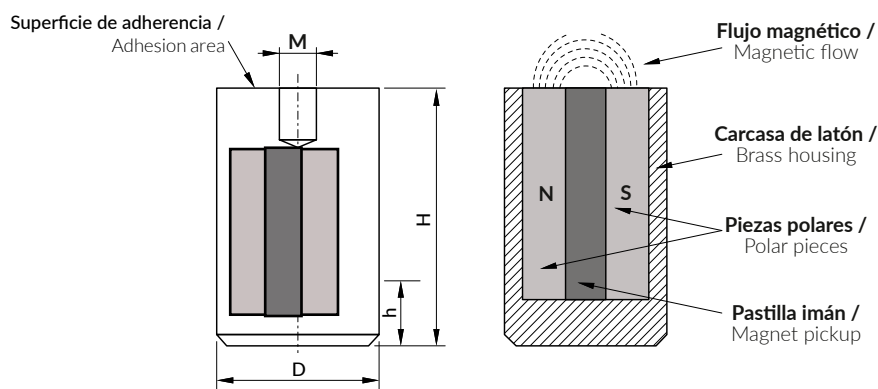

Material	T max de trabajo Máx. working temperature	m	D ^{h6} (mm)	H (mm)	h* (mm)	Fuerza / Force (kg)	Peso / Weight (g)	SEPARACIÓN** SEPARATION (mm)
NEODIMIO ND	80°C	M3x5	6	20	10	1	4,5	1,5
		M3x5	8	20	10	2,5	8	1,5
		M4x7	10	20	8	4,5	12,5	2
		M4x7	13	20	6	7	20	2,5
		M4x8	16	20	2	15	38	3
		M6x6	20	25	5	28	58	4
		M6x8	25	35	7	45	130	5
M6x6	32	40	4,5	70	243	6		

*La cota h indica la medida en que se puede reducir la altura H sin perjudicar en absoluto su fuerza de adherencia.
La superficie de adherencia no se puede rebajar más de 2 mm.

*The h parameter indicates the extent to which the height H can be reduced without impairing its adhesion strength. The adhesion surface can not be reduced by more than 2 mm.

**Separación mínima entre la carcasa exterior de la base y el hierro, para no disminuir su fuerza de atracción en caso de embutir la misma.

**Minimum separation between the outer casing base and iron, not to decrease its attraction in case of embedding it.

Forma de pedido: BM3NDH + D
How to order: BM3NDH + D

**BASE ALTA LISA BM4_ - BM5_
HIGH PLAIN BASE BM4_ - BM5_**

Ajustables en altura
Adjustable height

STOCK

BM4AL-BM5AL



Material: Samario Alnico / Alnico

BM4ND-BM5ND



Material: Neodimio / Neodymium

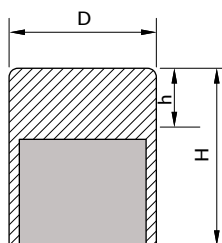

	Material	T max de trabajo Máx. working temperature	D ^{h6}	H ^{±0,2}	h* (mm)	Peso Weight (g)	Fuerza Force (N)	Fuerza Force (Kg)		Material	T max de trabajo Máx. working temperature	D ^{±0,1}	H ^{±0,2}	h* (mm)	Peso Weight (g)	Fuerza Force (N)	Fuerza Force (Kg)		
																		BM4	BM5
NEODIMIO ND	80°C	4	10	5	1	2,5	0,25	NEODIMIO ND	80°C	4	20	15	2	2,5	0,25				
		5	10	5	1,5	4,5	0,45			5	20	15	3	4,5	0,45				
		6	10	5	2	6	0,6			6	20	15	4,5	6	0,6				
		8	12	7	5	12	1,2			8	20	15	8	12	1,2				
		10	16	11	10	24	2,4			10	20	15	12	24	2,4				
		13	18	13	18	60	6			13	20	15	21	60	6				
		16	20	15	31	90	9			16	20	15	31	90	9				
		20	25	18	61	135	13,5			20	25	18	61	135	13,5				
		25	30	22	114	190	19			25	35	27	133	190	19				
		32	35	27	217	340	34			32	40	32	249	340	34				
		ALNICO AL	450°C	6	10	2	2			2	0,2	ALNICO AL	450°C	6	20	12	4,5	2	0,2
				8	12	3	4,5			4	0,4			8	20	11	7,5	4	0,4
				10	16	6	9,5			8,5	0,85			10	20	10	12	8,5	0,85
				13	18	6	18			12	1,2			13	20	8	19	12	1,2
16	20			6	30	20	2	16	20	6	30			20	2				
20	25			5	57	40	4	20	25	5	58			40	4				
25	30			7	106	60	6	25	35	13	125			60	6				
32	35			4	187	160	16	32	40	9	220			160	16				
40	45			5	390	240	24	40	50	10	440			240	24				
50	50			5	639	400	40	50	60	10	813			400	40				
63	60	5	1175	660	66	63	65	10	1306	660	66								

*La cota h indica la medida en que se puede reducir la altura H sin perjudicar en absoluto su fuerza de adherencia. La superficie de adherencia no se puede rebajar más de 2 mm.

*The h parameter indicates the extent to which the height H can be reduced without impairing its adhesion strength. The adhesion surface can not be reduced by more than 2 mm.

Forma de pedido / How to order: BM4AL + D
BM4ND + D
Forma de pedido / How to order: BM5AL + D
BM5ND + D

BASE ALTA CON AGUJERO DE ROSCADO BM5H_
 HIGH PLAIN WITH THREAD BM5H_

BM5HAL

Material: Alnico / Alnico

BM5HND

Material: Neodimio / Neodymium

STOCK

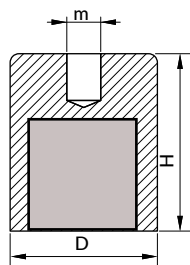

Material	T max de trabajo Máx. working temperature	D h6	H ±0,2	m	Peso Weight (g)	Fuerza Force (N)	Fuerza / Force (Kg)		
NEODIMIO ND	80°C	6	20	M 3x5	4	6	0,6		
		8	20	M 3x5	7,5	12	1,2		
		10	20	M 4x7	11	24	2,4		
		13	20	M 4x7	20	60	6		
		16	20	M 4x7	30	90	9		
		20	25	M 6x9	8	135	13,5		
		25	35	M 7x9	131	190	19		
		32	40	M 8x12	243	340	34		
		40	50	M 8x12	480	700	70		
		50	60	M 10x12	900	1000	100		
		63	65	M 12x14	1560	1700	170		
		ALNICO AL	450°C	6	20	M 3x5	4	2	0,2
				8	20	M 3x5	7,5	4	0,4
10	20			M 4x7	11	8,5	0,85		
13	20			M 4x7	19	12	1,2		
16	20			M 4x5	30	20	2		
20	25			M 6x7	55	40	4		
25	35			M 6x9	121	60	6		
32	40			M 8x9	220	160	16		
40	50			M 8x9	436	240	24		
50	60			M 10x12	794	400	40		
63	65			M 12x14	1274	660	66		

 Forma de pedido / How to order: **BM5HAL + D**
BM5HND + D

BASE BAJA LISA BM6_
LOW PLAIN BASE BM6_

Enfundado del imán en una carcasa metálica. Ofrece la singularidad de tener capacidad de atracción por una sola de las caras, quedando el resto de caras libres de acción magnética. Además, procura una mayor fuerza de agarre que el imán desnudo, así como de una gran variedad de opciones para su sujeción.

Coating of the magnet in a metal case. It offers the singularity of having only one face with attraction ability, leaving the rest of the faces free of magnetic action. In addition, it provides a greater gripping force than the naked magnet, as well as a wide variety of fastening options.

BM6ND



Material: Neodimio / Neodymium

BM6SC



Material: Samario Cobalto / Cobalt Samarium

BM6FE



Material: Ferrita / Ferrite

STOCK

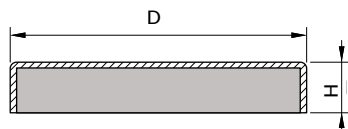

Material	T max de trabajo Máx. working temperature	D	H	Peso / Weight (g)	Fuerza / Force (N)	Fuerza / Force (Kg)
NEODIMIO ND	80°C	6	4,5	1	5	0,5
		8	4,5	1,5	13	1,3
		10	4,5	2,5	25	2,5
		13	4,5	4,5	60	6
		16	4,5	6,5	95	9,5
		20	6	15	140	14
		25	7	22	200	20
32	7	40	350	35		
SAMARIO COBALTO SC	200°C	6	4,5	1	5	0,5
		8	4,5	1,5	11	1,1
		10	4,5	2,5	20	2
		13	4,5	4,5	40	4
		16	4,5	6,5	60	6
		20	6	15	90	9
		25	7	22	150	15
32	7	40	220	22		
FERRITA FE	200°C	10	4,5	2	4	0,4
		13	4,5	3	10	1
		16	4,5	4,5	18	1,8
		20	6	10	30	3
		25	7	19	40	4
		32	7	30	80	8
		40	8	55	125	12,5
		50	10	100	220	22
		63	14	230	350	35
		80	18	485	600	60
100	22	900	900	90		
125	26	1680	1300	130		

Forma de pedido / How to order: BM6FE + D
BM6ND + D
BM6SC + D

BASE BAJA CON AGUJERO PASANTE BM6T_ LOW PLAIN BASE WITH THRU HOLE BM6T_

Enfundado del imán en una carcasa metálica. Ofrece la singularidad de tener capacidad de atracción por una sola de las caras, quedando el resto de caras libres de acción magnética. Además, procura una mayor fuerza de agarre que el imán desnudo, así como de una gran variedad de opciones para su sujeción.

Coating of the magnet in a metal case. It offers the singularity of having only one face with attraction ability, leaving the rest of the faces free of magnetic action. In addition, it provides a greater gripping force than the naked magnet, as well as a wide variety of fastening options.

BM6TND



Material: Neodimio / Neodymium

BM6TSC



Material: Samario Cobalto / Cobalt Samarium

BM6TFE



Material: Ferrita / Ferrite

STOCK

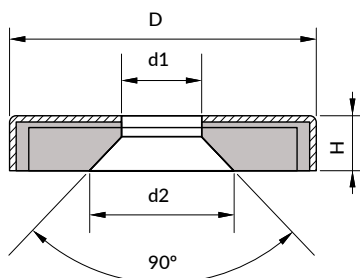

Material	T max de trabajo Máx. working temperature	D	H	d1	d2	Peso / Weight (g)	Fuerza / Force (N)	Fuerza Force (Kg)
NEODIMIO ND	80°C	16	4,5	3,5	6,6	6	75	7,5
		20	6	4,5	9	12	105	10,5
		25	7	4,5	9	24	160	16
		32	7	5,5	11	39	310	31
		40	8	5,5	10,6	73	500	50
		50	10	8,5	19,5	140	900	90
		63	14	10,5	24	320	1500	150
		80	18	10,5	24	675	2500	250
SAMARIO COBALTO SC	280°C	100	22	12,5	29,2	1295	4000	400
		16	4,5	3,5	6,6	6	57	5,7
		20	6	4,5	9,3	13	81	8,1
		25	7	4,5	9,2	25	105	10,5
		32	7	5,5	11,5	40	235	23,5
FERRITA FE	200°C	40	8	5,5	11,5	75	540	54
		16	4,5	3,5	6,5	4	14	1,4
		20	6	4,1	9	9,4	27	2,7
		25	7	5,5	11,5	17	36	3,6
		32	7	5,5	11,5	27	72	7,2
		40	8	5,5	11,5	52	90	9
		50	10	8,5	22	85	180	18
		63	14	6,5	24,1	130	290	29
80	18	6,5	11,5	235	450	45		
83	18	10,5	32	458	600	60		
100	22	10,5	34	815	680	68		

Forma de pedido / How to order: BM6TFE + D
BM6TND + D
BM6TSC + D

BASE BAJA CON AGUJERO PASANTE ROSCADO BM6R_
LOW PLAIN BASE WITH THREAD BM6R_

Enfundado del imán en una carcasa metálica. Ofrece la singularidad de tener capacidad de atracción por una sola de las caras, quedando el resto de caras libres de acción magnética. Además, procura una mayor fuerza de agarre que el imán desnudo, así como de una gran variedad de opciones para su sujeción.

Coating of the magnet in a metal case. It offers the singularity of having only one face with attraction ability, leaving the rest of the faces free of magnetic action. In addition, it provides a greater gripping force than the naked magnet, as well as a wide variety of fastening options.

BM6RFE



Material: Ferrita / Ferrite

BM6RND



Material: Neodimio / Neodymium

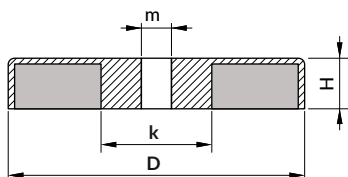

Material	T max de trabajo Máx. working temperature	D	H	m	k	Peso / Weight (g)	Fuerza / Force (N)	Fuerza / Force (Kg)
NEODIMIO ND	80°C	25 ±0,3	7 ±0,2	M 4	4,5	24	160	16
		32 ±0,3	7 ±0,2	M 5	5,5	40	330	33
		40 ±0,3	8 ±0,2	M 5	10,5	74	500	50
		50 ±0,3	10 ±0,2	M 8	9,5	140	800	80
		63 ±0,3	14 ±0,2	M 10	11,7	315	1100	110
		75 ±0,3	15 ±0,2	M10	13	479	1750	175
FERRITA FE	200°C	25	7	M 4	5,2	18	36	3,6
		32	7	M 5	5,2	30	75	7,5
		40	8	M 5	5,2	54	90	9
		50	10	M 8	12	95	170	17
		63	14	M 10	13	206	350	35
		80	18	M 10	14,5	472	550	55

Forma de pedido / How to order: BM6RFE + D
BM6RND + D

BASE BAJA TETÓN ROSCA HEMBRA **BM7_** LOW BASE ROUND (GRIP) WITH THREAD **BM7_**

Enfundado del imán en una carcasa metálica. Ofrece la singularidad de tener capacidad de atracción por una sola de las caras, quedando el resto de caras libres de acción magnética. Además, procura una mayor fuerza de agarre que el imán desnudo, así como de una gran variedad de opciones para su sujeción.

Coating of the magnet in a metal case. It offers the singularity of having only one face with attraction ability, leaving the rest of the faces free of magnetic action. In addition, it provides a greater gripping force than the naked magnet, as well as a wide variety of fastening options.

BM7ND



Material: Neodimio / Neodymium

BM7SC



Material: Samario Cobalto / Cobalt Samarium

BM7FE



Material: Ferrita / Ferrite

STOCK

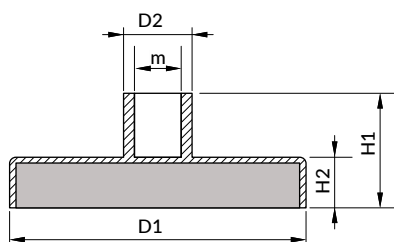

Material	T max de trabajo Máx. working temperature	D	H	H1	H2	m	Peso / Weight (g)	Fuerza Force (N)	Fuerza Force (Kg)
NEODIMIO ND	80°C	6	6	11,5	4,5	M 3	2	5	0,5
		8	6	11,5	4,5	M 3	3	13	1,3
		10	6	11,5	4,5	M 3	4	25	2,5
		13	6	11,5	4,5	M 3	5	60	6
		16	6	11,5	4,5	M 4	7,5	95	9,5
		20	8	13	6	M 4	16	140	14
		25	8	14	7	M 4	27	200	20
SAMARIO COBALTO SC	200°C	32	10	15,5	7	M 5	45	350	35
		6	6	11,5	4,5	M 3	2	5	0,5
		8	6	11,5	4,5	M 3	3	11	1,1
		10	6	11,5	4,5	M 3	4	20	2
		13	6	11,5	4,5	M 3	5	40	4
		16	6	11,5	4,5	M 4	7	60	6
		20	8	13	6	M 4	16	90	9
FERRITA FE	200°C	25	8	14	7	M 4	28	150	15
		32	10	15,5	7	M 5	47	220	22
		10	6	11,5	4,5	M 3	3	4	0,4
		13	6	11,5	4,5	M 3	4	10	1
		16	6	11,5	4,5	M 3	6	18	1,8
		20	6	13	6	M 3	11	30	3
		25	8	15	7	M 4	20	40	4
		32	8	15	7	M 4	31	80	8
		36	8	16	7,7	M 4	42	100	10
		40	10	18	8	M 5	59	125	12,5
		47	12	19	9	M 6	91	180	18
		50	12	22	10	M 6	111	220	22
		57	12	22,5	10,5	M 6	153	280	28
		63	15	30	14	M 8	243	350	35
80	20	34	18	M 10	477	600	60		
100	22	43	22	M 12	956	900	90		
125	25	50	26	M 14	1720	1300	130		

Forma de pedido / How to order: BM7FE + D

BM7ND + D

BM7SC + D

BASE BAJA TETÓN ROSCA MACHO BM7M_
LOW BASE ROUND (GRIP) WITH SCREW BM7M_

Enfundado del imán en una carcasa metálica. Ofrece la singularidad de tener capacidad de atracción por una sola de las caras, quedando el resto de caras libres de acción magnética. Además, procura una mayor fuerza de agarre que el imán desnudo, así como de una gran variedad de opciones para su sujeción.

Coating of the magnet in a metal case. It offers the singularity of having only one face with attraction ability, leaving the rest of the faces free of magnetic action. In addition, it provides a greater gripping force than the naked magnet, as well as a wide variety of fastening options.

BM7MFE



Material: Ferrita / Ferrite

BM7MND



Material: Neodimio / Neodymium

STOCK

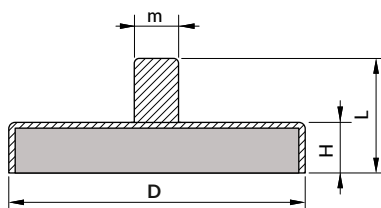

Material	T max de trabajo Máx. working temperature	D	H	L	m	Fuerza / Force (N)	Peso / Weight (g)
NEODIMIO ND	80°C	10 ±0,2	4,5 ±0,2	12,5 ±0,4	M 4	25	3
		13 ±0,2	4,5 ±0,2	12,5 ±0,4	M 5	60	5
		16 ±0,2	4,5 ±0,2	12,5 ±0,4	M 6	95	8
		20 ±0,2	6 ±0,2	16 ±0,4	M 6	140	15
		25 ±0,2	7 ±0,2	17 ±0,4	M 6	200	27
		32 ±0,2	7 ±0,2	17 ±0,4	M 6	350	42
FERRITA FE	200°C	10 ±0,3	4,5 ±0,2	11,5 ±0,3	M 3	4	2
		13 ±0,3	4,5 ±0,2	11,5 ±0,3	M 3	10	3
		16 ±0,3	4,5 ±0,2	11,5 ±0,3	M 3	18	5
		20 ±0,3	6 ±0,2	13 ±0,3	M 3	30	10
		25 ±0,3	7 ±0,2	15 ±0,3	M 4	40	20
		32 ±0,3	7 ±0,2	15 ±0,4	M 4	80	30
		47 ±0,3	9 ±0,3	17 ±0,4	M 6	180	85
		57 ±0,3	10,5 ±0,3	18,5 ±0,4	M 6	280	146
		63 ±0,3	14 ±0,3	29 ±0,4	M 6	350	233

Forma de pedido / How to order: BM7MFE + D
BM7MND + D

PINZAS MAGNÉTICAS PZM MAGNETIC CLIPS PZM

Indispensable en la operativa con prensas. Evitan introducir la mano del operario dentro de la matriz, dando total seguridad y facilitando el suministro de la plancha y la extracción del producto. El soporte de Nylon no daña los moldes y matrices.

Essensial for manual work in dies. They avoid introducing the operator's hand into the die, giving total security and facilitating the supply of the plate and the extraction of the product. The Nylon support does not damage the molds and dies.

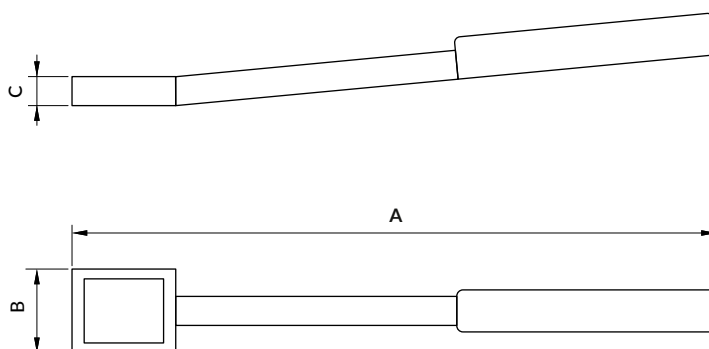

Referencia Reference	A	B	C	Peso / Weight (g)	Soporte / Support	Esfuerzo / Effort (Kg)
PZM1	265	25	20	275	Metálico	2
PZM2	350	95	30	315	Metálico	6

Forma de pedido: Referencia
How to order: Reference n°

ELEMENTOS DE TRANSPORTE LIFTING ELEMENTS



Todos los productos de esta gama son fabricados respetando rigurosamente los procedimientos establecidos por la Directiva Máquinas 2006/42/CE. El marcaje CE garantiza la conformidad del producto para satisfacer todas las exigencias de transporte de troqueles de cualquier dimensión y peso con total seguridad.

Safety is the password of lifting elements: all components of this series are designed and manufactured rigorously respecting the procedure established by the Directive Machine 2006/42/EC. The EC mark, guarantees the conformity of the item in order to satisfy every need in moving dies of every dimension and weight, in total safety.

ELEMENTOS DE TRANSPORTE LIFTING ELEMENTS

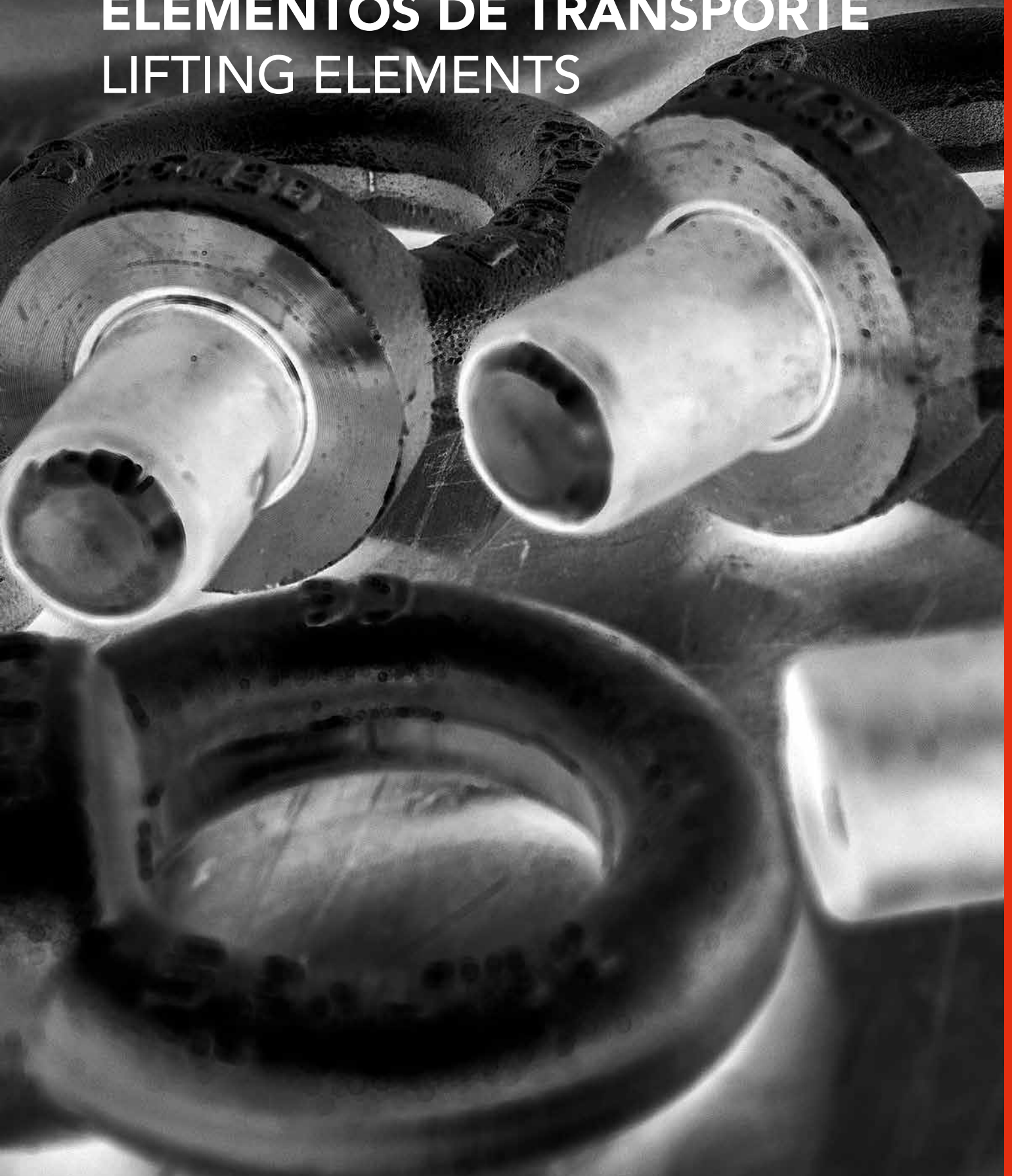

ÍNDICE INDEX

384

CÁNCAMO GIRATORIO CGL
ROTARY BRACKET CGL



-

386

CÁNCAMO ELEVACIÓN CEM
LIFTING BRACKET CEM



DIN 580

387

CÁNCAMO ELEVACIÓN CEH
LIFTING BRACKET CEH



DIN 582

388

SOPORTE DE ELEVACIÓN CEW
LIFTING BRACKET CEW



-

389

OREJETA DE TRANSPORTE OTF
LIFTING BRACKET WITH PIN OTF



-

390

OREJETA DE TRANSPORTE OTB
LIFTING BRACKET WITH PIN OTB



BMW

391

BULÓN DE TRANSPORTE BTW
LIFTING PIN BTW



VDI 3366

392

BULÓN DE TRANSPORTE BTP
LIFTING PIN BTP



PSA-RENAULT

393

BULÓN DE TRANSPORTE BTB
LIFTING PIN BTB



BMW

394

BULÓN DE TRANSPORTE BTF
LIFTING PIN BTF



FCA

395

BOLA TRANSPORTADORA BT
TRANSPORTATION BALL BT



-

CÁNCAMO GIRATORIO CGL ROTARY BRACKET CGL

STOCK

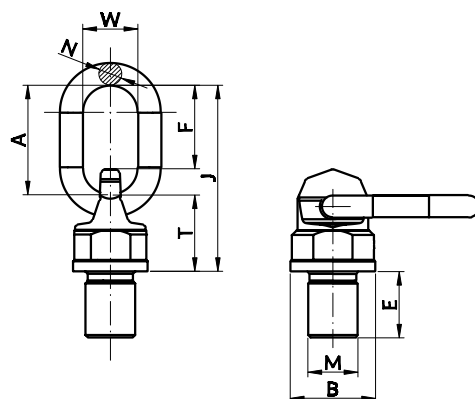

CE 2006/42/CE

M	E mm	B mm	T mm	F mm	A mm	W mm	N mm	J	Carga / Capacity t	Peso / Weight Kg
M8	12	40	46	44	52	30	12	98	0,3	0,5
M10	19	40	46	44	52	30	12	98	0,45	0,5
M12	19	40	46	44	52	30	12	98	0,6	0,5
M14	31,8	40	46	44	52	30	12	98	1	0,5
M16	31,8	40	46	44	52	30	12	98	1,3	0,5
M18	38,1	70	75	67	85	40	20	160	1,8	2,5
M20	38,1	70	75	67	85	40	20	160	2	2,5
M22	38,1	70	75	67	85	40	20	160	2	2,5
M24	38,1	70	75	67	85	40	20	160	3,5	2,5
M30	50	79	91	95	115	51	22	206	6	4
M33	50	79	91	95	115	51	22	206	6	4
M36	54	79	91	95	115	51	22	206	8	4
M39	58	79	91	95	115	51	22	206	8	4
M42	63	93	100,5	108	130	65	26	230,5	12	6
M45	68	93	100,5	108	130	65	26	230,5	12	6
M48	68	93	100,5	108	130	65	26	230,5	13	6
M52	84	105	132	120	146	70	32	278	14	11
M56	84	105	132	120	146	70	32	278	16	11
M60	90	105	132	120	146	70	32	278	16	11
M64	95	105	132	120	146	70	32	278	16	11

Continúa en la siguiente página...
Continue next page...

Forma de pedido: CGL + M*B
How to order: CGL + M*B

CE 2006/42/CE

Capacidad t / Capacity t

Referencia Reference	0°		90°		0-45° 45-60°		Asimétrico Asymmetry		0-45° 45-60°		Asimétrico Asymmetry	
	1 ramal piece	2 ramales pieces	1 ramal piece	2 ramales pieces	2 ramales pieces	2 ramales pieces	2 ramales pieces	3-4 ramales pieces	3-4 ramales pieces	3-4 ramales pieces	3-4 ramales pieces	3-4 ramales pieces
CGL M8*40	0,6	1,2	0,3	0,6	0,4	0,3	0,3	0,6	0,4	0,3		
CGL M10*40	0,9	1,8	0,45	0,9	0,6	0,45	0,4	0,9	0,6	0,4		
CGL M12*40	1,2	2,4	0,6	1,2	0,8	0,6	0,6	1,2	0,9	0,6		
CGL M14*40	2	4	1	2	1,4	1	1	2,1	1,5	1		
CGL M16*40	2,6	5,2	1,3	2,6	1,8	1,3	1,3	2,7	1,9	1,3		
CGL M18*70	3,6	7,2	1,8	3,6	2,5	1,8	1,8	3,7	2,7	1,8		
CGL M20*70	4	8	2	4	2,8	2	2	4,2	3	2		
CGL M22*70	4	8	2	4	2,8	2	2	4,2	3	2		
CGL M24*70	7	14	3,50	7	4,9	3,5	3,5	7,3	5,2	3,5		
CGL M30*79	10	20	5	10	7	5	5	10,5	7,5	5		
CGL M33*79	15	30	6	12	8,4	6	6	12,6	9	6		
CGL M36*79	15	30	8	16	11,2	8	8	16,8	12	8		
CGL M39*79	15	30	8	16	11,2	8	8	16,8	12	8		
CGL M42*93	17	34	12	24	16,8	12	12	25,2	18	12		
CGL M45*93	17	34	12	24	16,8	12	12	25,2	18	12		
CGL M48*93	18	36	13	26	18,2	13	13	27,3	19,5	13		
CGL M52*105	25	50	14	28	19,6	14	14	29,4	21	14		
CGL M56*105	28	56	16	32	22,4	16	16	33,6	24	16		
CGL M60*105	28	56	16	32	22,4	16	16	33,6	24	16		
CGL M64*105	28	56	16	32	22,4	16	16	33,6	24	16		

Forma de pedido: CGL + M*B

How to order: CGL + M*B

CÁNCAMO ELEVACIÓN CEM LIFTING BRACKET CEM

STOCK

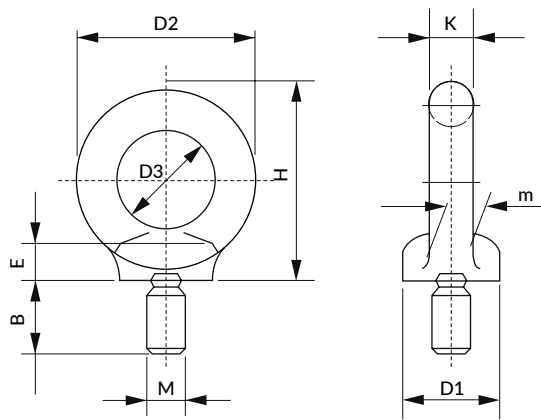

CE 2006/42/CE

Norma / Standard: DIN 580

M	B min	D1	D2	D3	E	H	K	m	Peso / Weight kg	Capacidad t / Capacity t	
										1 ramal / piece 0°	2 ramales / piezas 0-45°
M6	11	20	36	15	6	36	8	10	0,03	0,08	0,055
M8	13	20	36	20	6	36	8	10	0,06	0,14	0,095
M10	17	25	45	25	8	45	10	12	0,11	0,23	0,17
M12	20,5	30	54	30	10	53	12	14	0,18	0,34	0,24
M16	27	35	63	35	12	62	14	16	0,28	0,7	0,5
M20	30	40	72	40	14	71	16	19	0,45	1,2	0,83
M22	33	50	90	42	18	90	20	24	0,72	1,4	1,05
M24	36	50	90	50	18	90	20	24	0,74	1,8	1,27
M30	45	65	108	60	22	109	24	28	1,66	3,6	2,6
M36	54	75	126	70	26	128	28	32	2,65	5,1	3,7
M42	63	85	144	80	30	147	32	38	4,03	7	5
M48	68	100	166	90	35	168	38	46	6,38	8,6	6,1
M56	78	110	184	100	38	187	42	50	8,8	11,5	8,3
M64	90	120	206	110	42	208	48	58	12,4	16	11
M72	100	150	260	140	50	260	60	72	23,3	21	15
M80	112	170	296	160	55	298	68	80	34,2	28	20

Forma de pedido: CEM + M

How to order: CEM + M

CÁNCAMO ELEVACIÓN CEH LIFTING BRACKET CEH

STOCK

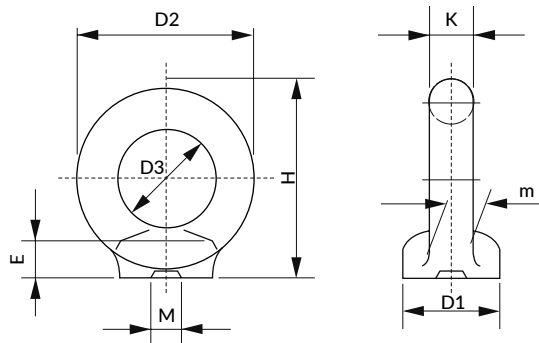

CE 2006/42/CE

Norma / Standard: DIN 582

M	D1	D2	D3	E	H	K	m	Peso / Weight kg	Capacidad t / Capacity t	
									1 ramal / pieza 0°	2 ramales / piezas 0-45°
M6	20	36	15	8,5	36	8	10	0,05	0,08	0,055
M8	20	36	20	8,5	36	8	10	0,05	0,14	0,095
M10	25	45	25	10	45	10	12	0,09	0,23	0,17
M12	30	54	30	11	53	12	14	0,16	0,34	0,24
M16	35	63	35	13	62	14	16	0,24	0,7	0,5
M20	40	72	40	16	71	16	19	0,36	1,2	0,83
M22	50	90	42	20	90	20	24	0,73	1,4	1,05
M24	50	90	50	20	90	20	24	0,72	1,8	1,27
M30	65	108	60	25	109	24	28	1,32	3,6	2,6
M36	75	126	70	30	128	28	32	2,08	5,1	3,7
M42	85	144	80	35	147	32	38	3,11	7	5
M48	100	166	90	40	168	38	46	5,02	8,6	6,1
M56	110	184	100	45	187	42	50	6,69	11,5	8,3
M64	120	206	110	50	208	48	58	9,3	16	11
M72	150	260	140	60	260	60	72	18,5	21	15
M80	170	296	160	70	298	68	80	27,3	28	20

Forma de pedido: CEH + M
How to order: CEH + M

SOPORTE DE ELEVACIÓN CEW LIFTING BRACKET CEW

Material: CK45 - 700÷800 N/mm²



i Se recomienda montaje con tornillo TCC
We recommend assembly with screw TCC

Forma / Form A

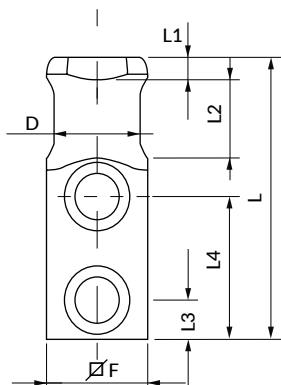

Forma / Form B

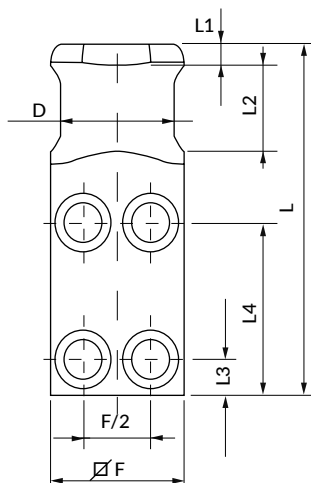

CE 2006/42/CE

D	L	L1	L2	L3	L4	F	H	Forma Form	Carga Máx. Max. Load Kg	Peso Máx. Matriz Max. Die weight Kg	Tornillo Screw
16	80	6	20	10	44	20	6	A	320	640	M 8 x 25
20	90	8	25	10	47	25	8	A	630	1260	M 10 x 30
25	100	8	30	12	50	35	10	A	1250	2500	M 12 x 40
32	120	10	32	16	62	40	10	A	2000	4000	M 16 x 45
40	140	10	40	18	72	50	12	A	3200	6400	M 20 x 60
50	160	12	45	22	81	60	14	A	5000	10000	M 24 x 70
63	200	12	50	20	98	80	16	B	8000	16000	M 20 x 90
80	250	15	65	25	125	100	18	B	12500	25000	M 24 x 110
100	300	15	80	30	155	120	20	B	20000	40000	M 30 x 130

Forma de pedido: CEW + D
How to order: CEW + D

OREJETA DE TRANSPORTE OTF LIFTING BRACKET WITH PIN OTF

Material: CK45 - 800÷1000 N/mm²



i Se recomienda montaje con tornillo TCC
We recommend assembly with TCC screw

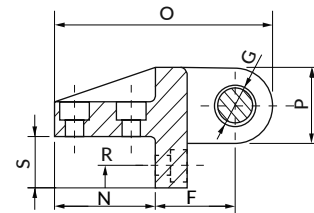
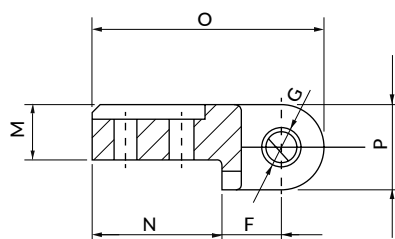
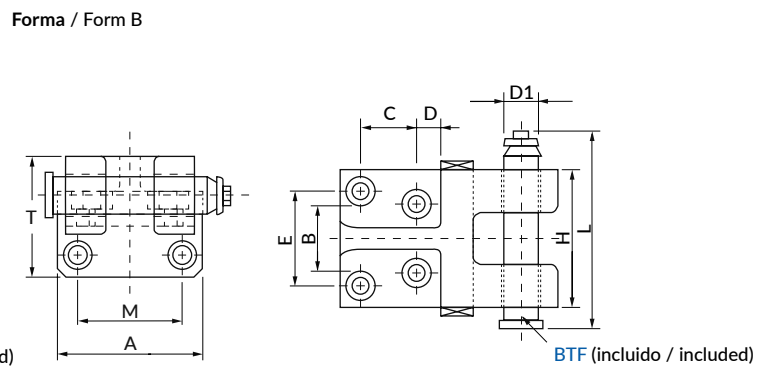
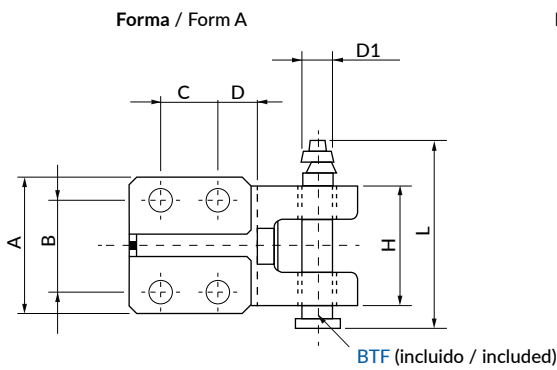

CE 2006/42/CE

Carga Máx. Max. Load Kg	Peso Máx. Matriz Max. Die weight Kg	A	B	C	D	D1	E	F	G	H	L	M	N	O	P	R	S	T	Forma Form	Tornillo Screw
600	1200	80	50	40	22,5	15,6	-	39	16	70	102,5	32	80	145	52	-	-	-	A	M 12 x 45
1000	2000	90	60	40	27,5	20,6	-	42	21	79	113,5	36	90	160	56	-	-	-	A	M 16 x 55
2000	4000	100	65	65	32,5	25,6	-	60	26	90	128,5	50	120	215	70	-	-	-	A	M 20 x 80
4000	8000	135	56	60	20	33	84	85	34	125	166,5	96	100	221	72	30	50	111	B	M 16 x 45
7000	14000	180	80	70	30	43	110	100	44	160	210,5	130	125	270	90	35	60	140	B	M 20 x 60

Forma de pedido: OTF + Carga Máx.

How to order: OTF + Max. Load

OREJETA DE TRANSPORTE OTB COMPLETE LIFTING BRACKET OTB

Material: St52



i Se recomienda montaje con tornillo TCC
We recommend assembly with TCC screw

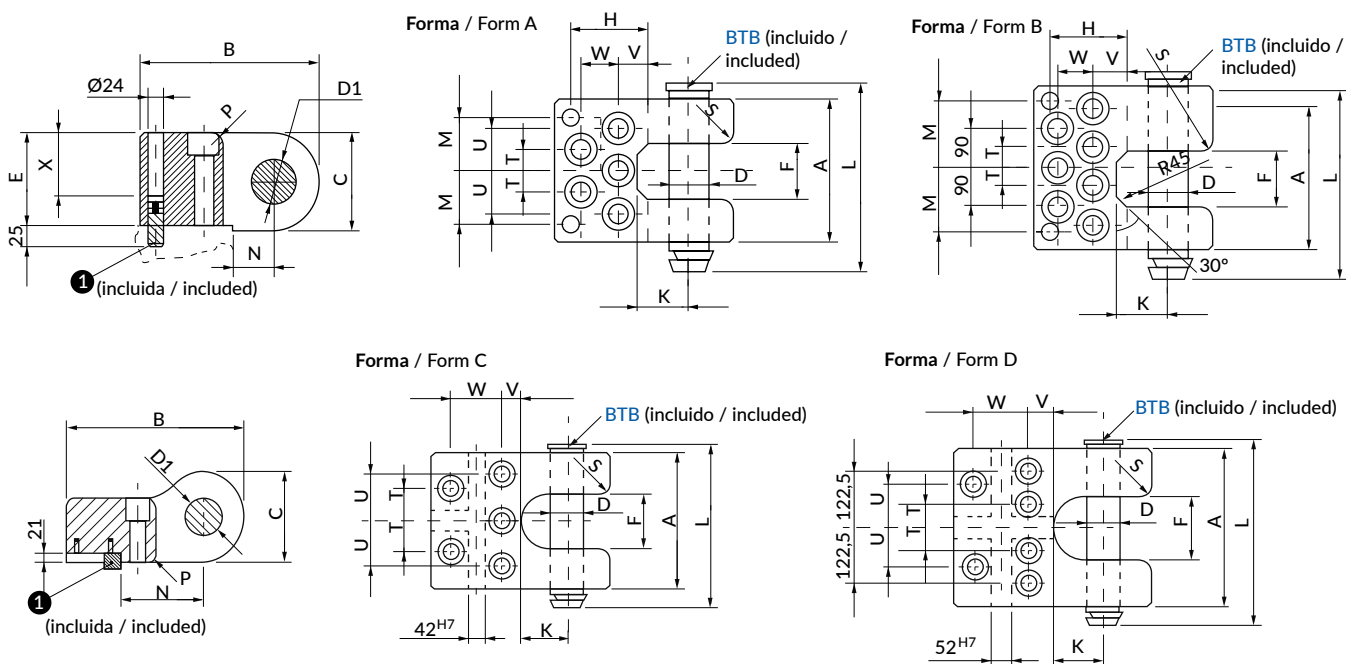

1 Para formas A y B: muñequilla MQW / For shapes A and B: locating pin MQW
Para formas C y D: chaveta CHO / For shapes C and D: key CHO

CE 2006/42/CE

Carga Máx. Max. Load Kg	Peso Máx. Matriz / Max. Die weight Kg	A	B	C	D	D1	E	F	H	K	L	M	N	P	S	T	U	V	W	X	Forma Form	Tornillo Screw
3200	6400	126	185	80	30	32	75	50	85	-	158	45	40	12	16	20	40	30	35	40	A	M 16 x 80
5000	10000	150	210	100	40	42	95	60	87	-	187	52	50	12	20	22,5	45	25	40	60	A	M 20 x 100
8000	16000	175	240	120	50	52	115	75	95	-	220	62,5	60	16	24	25	50	35	45	80	A	M 24 x 120
12500	25000	200	300	140	60	62	130	80	145	-	246	77,5	65	20	30	35	65	60	65	95	A	M 36 x 160
18000	36000	250	300	160	80	82	150	100	105	-	305	100	90	20	30	30	60	30	60	115	B	M 30 x 160
25000	50000	300	435	200	80	82	140	120	-	115	360	-	199	30	30	70	100	45	125	-	C	M 36 x 160 (x5)
31500	63000	345	480	240	80	82	170	135	-	130	405	-	220	30	30	50	85	50	130	-	D	M 36 x 200 (x6)

Forma de pedido: OTB + Carga Máx.
How to order: OTB + Max. Load

BULÓN DE TRANSPORTE BTW LIFTING PIN BTW

Material: CK 45

STOCK

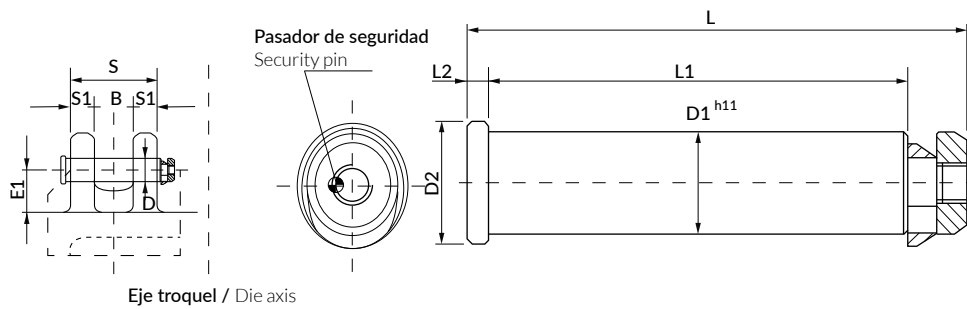

CE 2006/42/CE

Carga Max. Max Load Kg	Peso Max. matriz Max Die weight Kg	B	D	D1	D2	E1	L	L1	L2	S	S1
3200	6400	60	34	32	40	63	175	145	10	140	40
5000	10000	80	42	40	50	80	225	188	10	180	50
8000	16000	100	52	50	60	100	273	230	11	220	60
12500	25000	120	65	63	75	125	347	295	14	280	80
31500 *	63000	140	78	76	95	160	422	360	15	340	100

* Material: 42CrMo4 + QT

Forma de pedido: BTW + D1*L1

How to order: BTW + D1*L1



BULÓN DE TRANSPORTE BTP LIFTING PIN BTP

Material: St52

STOCK

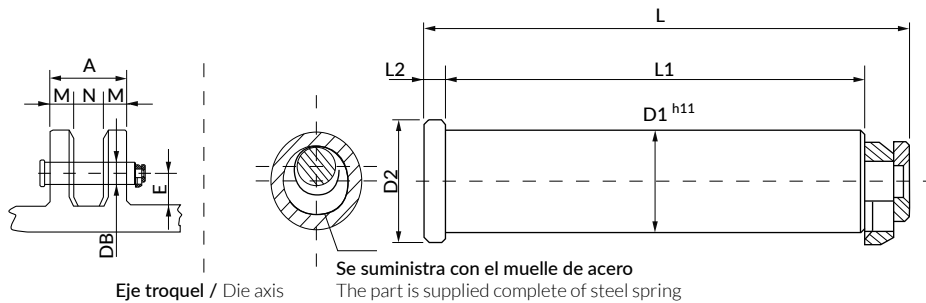

CE 2006/42/CE

Carga Max. Max Load Kg	Peso Max. matriz Max Die weight Kg	A	E	DB	D1	D2	L	L1	L2	M	N
6000	12000	125	55	34	32	40	154	132	6	37,5	50
9000	18000	160	70	42	40	50	197,5	170	8	47,5	65
14000	28000	200	90	52	50	63	247,5	212	10	60	80
22500	45000	250	100	65	63	80	309	265	12	75	100

Forma de pedido: BTP + D1*L1

How to order: BTP + D1*L1

BULÓN DE TRANSPORTE BTB LIFTING BRACKET BTB

Material: CK 45

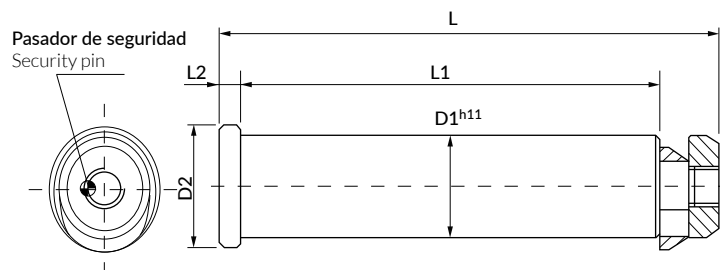

CE 2006/42/CE

Carga Max. Max Load Kg	Peso Max. matriz Max Die weight Kg	D1	D2	L	L1	L2
3200	6400	30	40	158	129	10
5000	10000	40	50	187	155	10
8000	16000	50	60	220	180	11
12500	25000	60	70	246	205	11
18000	36000	80	90	305	255	12
25000 *	50000	80	90	360	310	12
31500 *	63000	80	90	405	355	22

* Material: 42CrMo4 + QT

Forma de pedido: BTB + D1*L1

How to order: BTB + D1*L1

BULÓN DE TRANSPORTE BTF LIFTING BRACKET BTF

Material: CK45

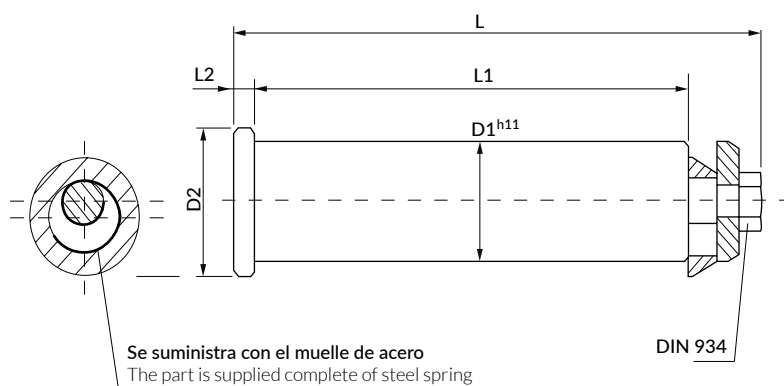

CE 2006/42/CE

Carga Max. Max Load Kg	Peso Max. matriz Max Die weight Kg	D1	D2	L	L1	L2
600	1200	15,6	25	102,5	77	6
1000	2000	20,6	30	113,5	86	6
2000	4000	25,6	35	128,5	100	6
4000	8000	33	43	166,5	135	6
7000	14000	43	53	210,5	175	8

Forma de pedido: BTF + D1*L1
How to order: BTF + D1*L1

BOLA TRANSPORTADORA BT TRANSPORTATION BALL BT

Material: Bola de acero al carbono y carcasa zincada / Carbon steel bearing and zinc plated pressing

STOCK



BT0

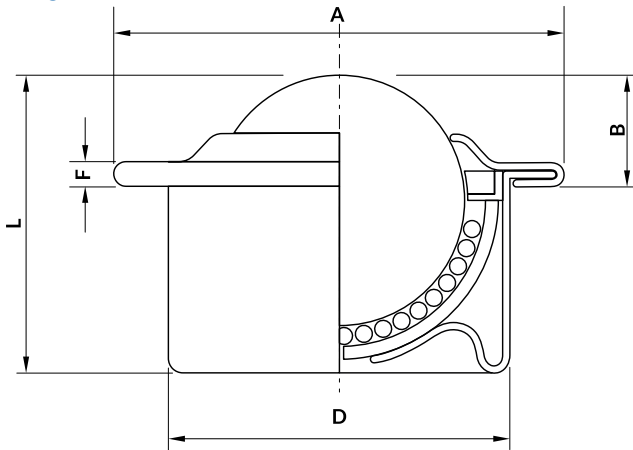

BT4

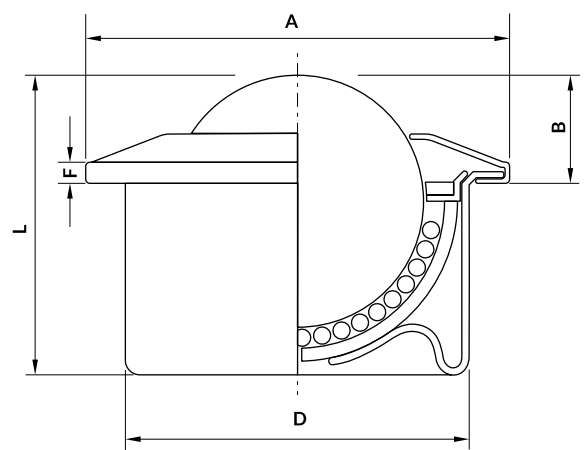

Referencia Reference	Diametro de bola (mm) Ball diameter (mm)	Dimensiones (mm) / Dimensions (mm)					Carga dinámica máxima (Kg) / Maximum dynamic loading (Kg)	
		A	B	D	F	L	Peso (Kg) Weight (Kg)	Capacidad de carga (Kg) Capacity (Kg)
BT0-15 BT4-15	15,80	31,00	9,5±0,2	24±0,065	2,80	21,00	0,04	60,00
BT0-22 BT4-22	22,20	45,00	9,8±0,2	36±0,08	2,80	30,00	0,13	160,00
BT0-30 BT4-30	30,00	55,00	13,8±0,3	45±0,08	4,00	37,00	0,28	300,00
BT0-45 BT4-45	44,50	75,00	19±0,4	62±0,095	4,00	53,50	0,73	610,00

Forma de pedido: Referencia
How to order: Reference

ELEMENTOS DE TRAZABILIDAD TRACEABILITY ELEMENTS



Dentro de nuestra gama de elementos de trazabilidad, ofrecemos unidades de marcaje con ruedas móviles que facilitan el cambio de numeración sin necesidad de desmontar del troquel. Además también encontrarás una amplia gama de marcadores y porta marcadores que se adaptan a las necesidades de marcaje en el proceso de estampación.

Además, podemos diseñar y fabricar productos especiales, para dar solución a necesidades específicas de producción.

Our range of traceability elements offers STAMPs with mobile wheels to facilitate the change of numbers, without having to remove it from the die. Moreover, we also have a vast variety of markers and stamp retainers designed to satisfy marking needs during the stamping process.

In addition, we can design and manufacture special products, according to special designs and particular production needs.

ELEMENTOS DE TRAZABILIDAD

TRACEABILITY ELEMENTS

ÍNDICE INDEX

400

PORTAMARCADOR PRMP
STAMP RETAINER PRMP



-

400

MARCADOR PMP
STAMP PMP



-

401

MARCADOR PMM
STAMP PMM



-

401

MARCADOR PMR
STAMP PMR



-

402

PORTAMARCADOR PRMV
STAMP RETAINER PRMV



-

403

MARCADOR PMV
STAMP PMV



-

404

PORTAMARCADOR PRMW
STAMP RETAINER PRMW



-

405

MARCADOR PMW
STAMP PMW



-

406

MARCADOR UM
STAMP UM



-

407

MARCADOR PMS
STAMP PMS



-

PORTAMARCADOR PRMP STAMP RETAINER PRMP

STOCK

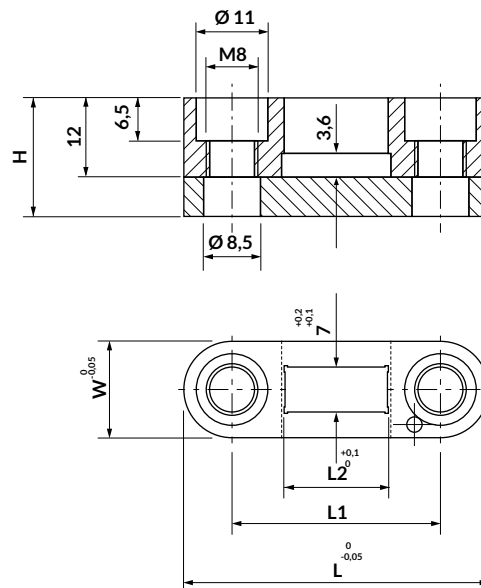

i Para montar con los marcadores PMP, PMM o PMR.
Assembly with PMP, PMM or PMR stamp.

W	H	L	L1	L2	Nº de sellos (PMP o PMM)	Nº de sellos (PMR)
15	18	45	30	12	3	6
15	18	47	32	16	4	8
15	18	55	40	24	6	12
15	18	63	48	32	8	16
15	18	71	56	40	10	20

Forma de pedido: PRMP + L
How to order: PRMP + L

MARCADOR PMP STAMP PMP

Grabado mecanizado / Machined engraving

Material: 1.2842

Dureza / Hardness: 58-60 HRC

STOCK

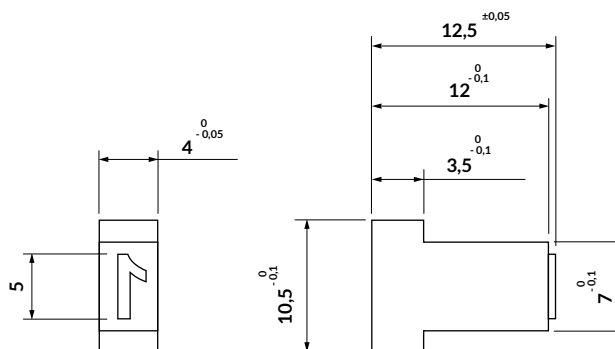

i Para montar con el portamarcador PRMP.
Assembly with PRMP stamp retainer.

Caracteres disponibles
Available characters

NÚMEROS	0-9
LETRAS	A-Z
BARRA	/
ESPACIO	
GUIÓN MEDIO	-
GUIÓN BAJO	-

Forma de pedido: PMP + Carácter
How to order: PMP + Character

MARCADOR PMM STAMP PMM

Grabado mecanizado / Machined engraving
Material: 1.2842
Dureza / Hardness: 58-60 HRC

STOCK

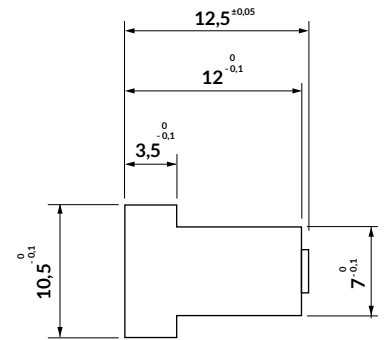
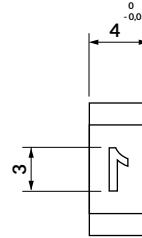

i Para montar con el portamarcador PRMP.
Assembly with PRMP stamp retainer.

Caracteres disponibles
Available characters

NÚMEROS	0-9
LETRAS	A-Z
BARRA	/
ESPACIO	
GUIÓN MEDIO	-

Forma de pedido: PMM + Carácter
How to order: PMM + Character

MARCADOR PMR STAMP PMR

Grabado mecanizado / Machined engraving
Material: 1.2842
Dureza / Hardness: 58-60 HRC

STOCK

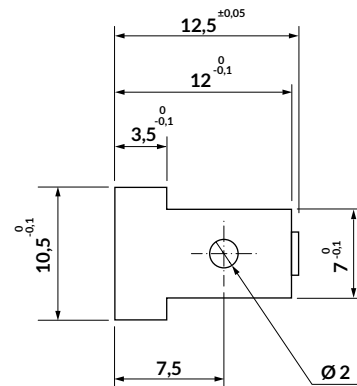
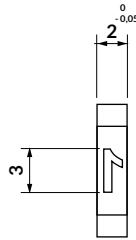

i Para montar con el portamarcador PRMP.
Assembly with PRMP stamp retainer.

Caracteres disponibles
Available characters

NÚMEROS	0-9
LETRAS	A-Z
BARRA	/
ESPACIO	
GUIÓN MEDIO	-
GUIÓN BAJO	-

Forma de pedido: PMR + Carácter
How to order: PMR + Character

PORTAMARCADOR PRMV STAMP RETAINER PRMV

STOCK



Tipo A / Type A

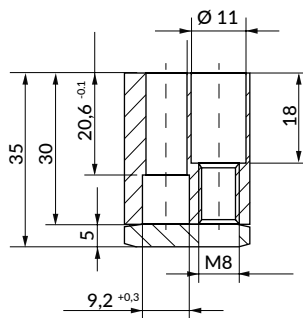

Tipo B / Type B

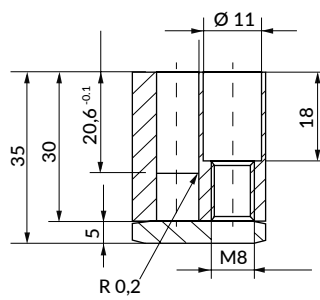

Tipo C / Type C

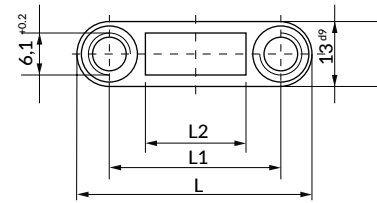
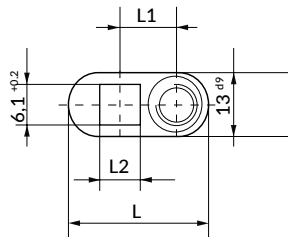
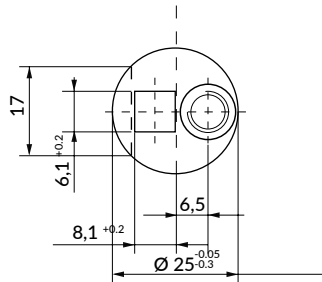
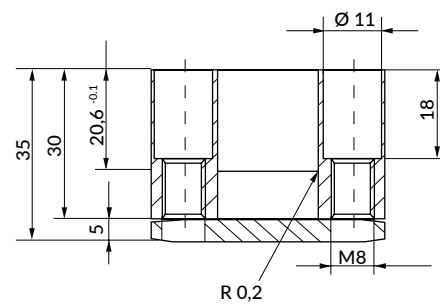

i Para montar con el marcador PMV.
Assembly with PMV stamp.

L ^{Ø9}	L1 ±0,1	L2 ^{+0,2}	Nº de sellos / Nº of markers	Tipo / Type
-	-	-	2	A
24	9	4,1	1	B
28	11	8,1	2	
32	13	12,1	3	
43	30	16,1	4	C
47	34	20,1	5	
51	38	24,1	6	
67	54	40,1	10	
71	58	44,1	11	

Forma de pedido: PRMV + Tipo + L
How to order: PRMV + Type + L

MARCADOR PMV STAMP PMV

Material: 1.2080
Dureza / Hardness: 62+2 HRC

STOCK

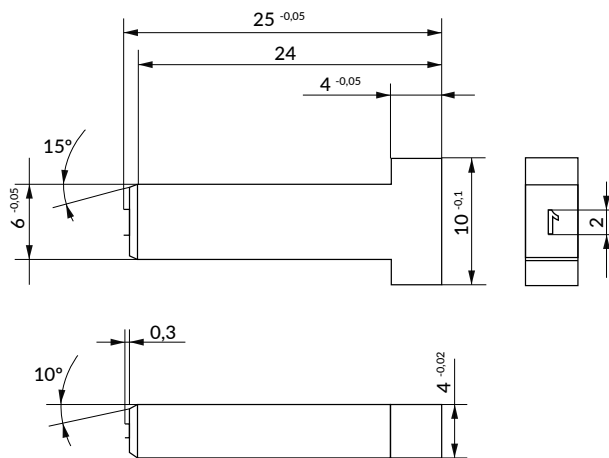

i Para montar con el portamarcador **PRMV**.
Assembly with **PRMV** stamp retainer.

Caracteres disponibles / Available characters

Números / Numbers	Letras / Letters
0-9	A-Z

Forma de pedido: PMV + Carácter
How to order: PMV + Character

PORTAMARCADOR PRMW STAMP RETAINER PRMW

STOCK

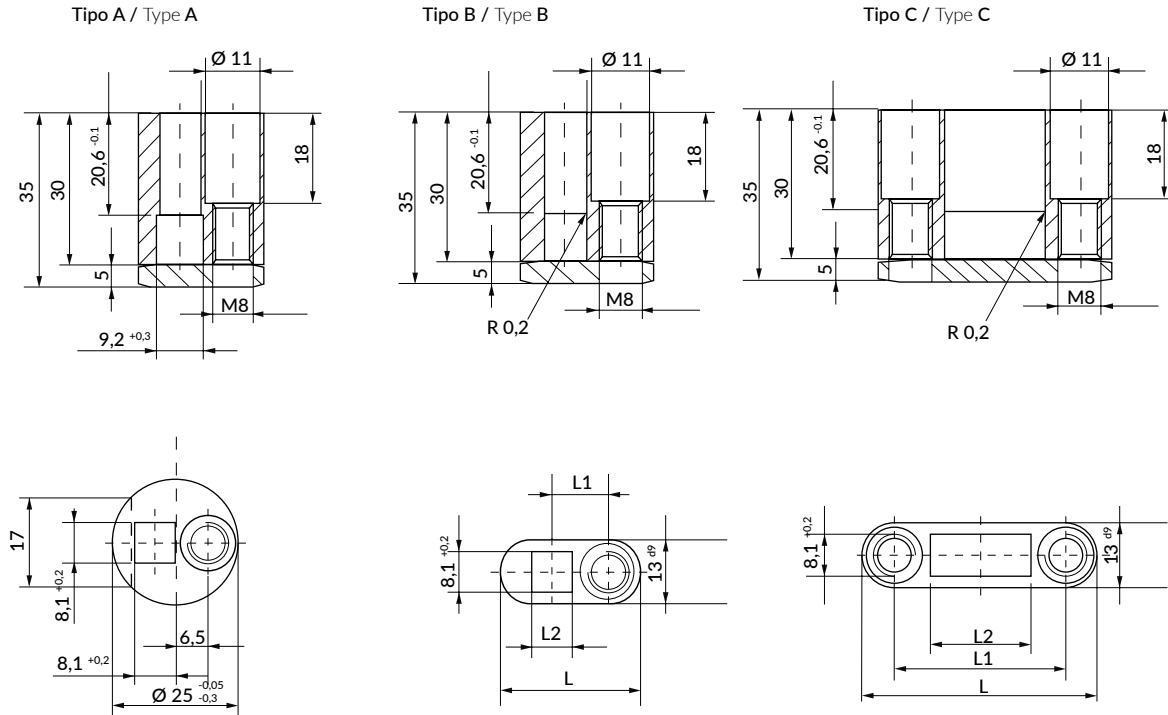

i Para montar con el marcador **PMW**.
Assembly with **PMW** stamp.

L ^{d9}	L1 ^{+0.1}	L2 ^{+0.2}	Nº de sellos / N° of markers	Tipo / Type
-	-	-	2	A
24	9	4,1	1	B
28	11	8,1	2	
32	13	12,1	3	
43	30	16,1	4	
47	34	20,1	5	
51	38	24,1	6	C
67	54	40,1	10	
71	58	44,1	11	

Forma de pedido: PRMW + Tipo + L
How to order: PRMV + Type + L

MARCADOR PMW STAMP PMW

Material: 1.2080

Dureza / Hardness: 62+2 HRC

STOCK

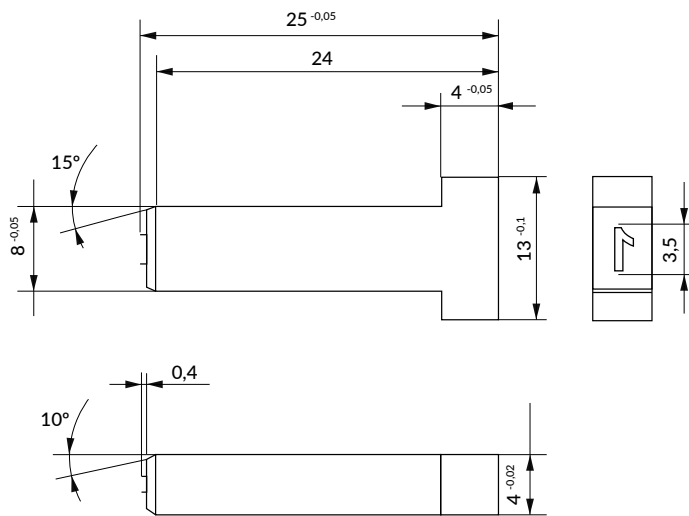

i Para montar con el portamarcador **PRMW**.
Assembly with **PRMW** stamp retainer.

Caracteres disponibles / Available characters

Números / Numbers	Letras / Letters
0-9	A-Z

Forma de pedido: PMW + Carácter
How to order: PMW + Character

MARCADOR UM STAMP UM

STOCK

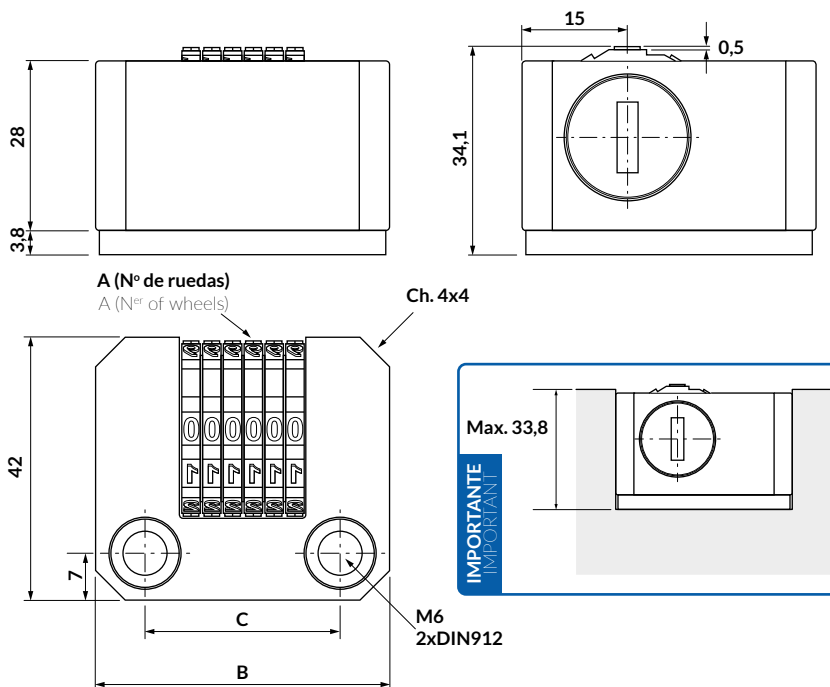

Referencia Reference n°	A	B	C	Posición caracteres Characters position
UM.043642	4	36	22	Según croquis - Regarding drawing
UM.064242	6	42	28	Según croquis - Regarding drawing
UM.0436RV	4	36	22	Inverso a croquis - Inverse to drawing
UM.0642RV	6	42	28	Inverso a croquis - Inverse to drawing

Forma de pedido: Referencia
How to order: Reference n°

MARCADOR PMS STAMP PMS

Grabado mecanizado / Machined engraving
Material: 1.2842
Dureza / Hardness: 58-60 HRC

STOCK

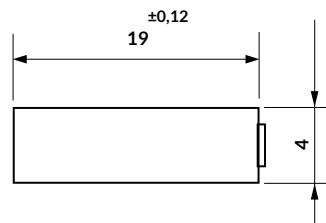
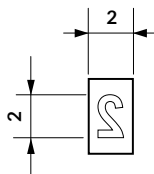

Caracteres disponibles Available characters

NÚMEROS	0-9
LETRAS	A-Z
BARRA	/
ESPACIO	
GUIÓN MEDIO	-

Forma de pedido: PMS + Carácter
How to order: PMS + Character

ACEROS Y LÁMINAS STEEL AND SHEETS

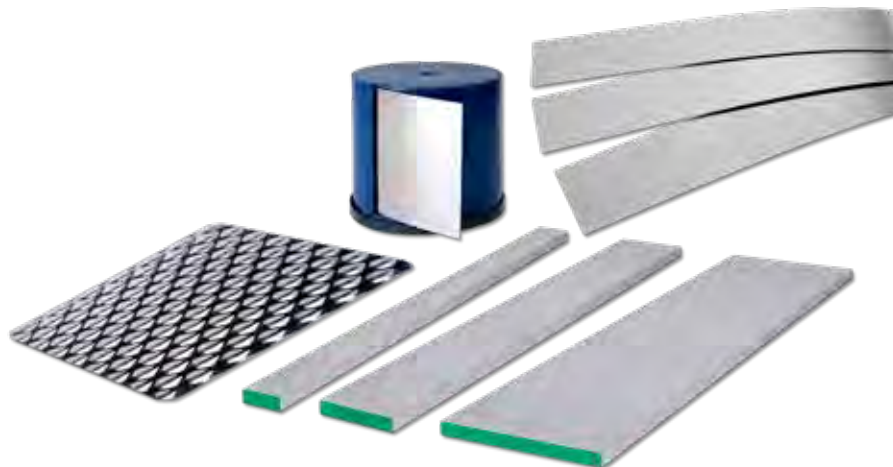

En este apartado podrás encontrar distintos materiales en diversos formatos y acabados para diferentes aplicaciones de fabricación y mantenimiento: placas de acero, barras de acero plata, cinta calibrada o chapa lagrimada.

[También disponemos de otro tipo de materiales bajo pedido.](#)

In this section you can find different materials in different formats and finishes for different manufacturing and maintenance applications: steel plates, steel silver bars, precision foils or patterned stainless steel sheets.

[We also have other types of materials on request.](#)

ACEROS Y LÁMINAS STEEL AND SHEETS



ÍNDICE INDEX

412

**PLACAS DE ACERO
RECTIFICADAS (500mm) PLRH**
PRECISION GROUND PLATES
(500mm) PLRH



413

**PLACAS DE ACERO
RECTIFICADAS (1000mm) PLRH**
PRECISION GROUND PLATES
(1000mm) PLRH



414

**PLACAS DE ACERO
RECTIFICADAS (500mm) PLRC**
PRECISION GROUND PLATES
(500mm) PLRC



415

**PLACAS DE ACERO
RECTIFICADAS (1000mm) PLRC**
PRECISION GROUND PLATES
(1000mm) PLRC



416

CINTA CALIBRADA GPR
PRECISION FOILS GPR



417

CINTA CALIBRADA GPL
PRECISION FOILS GPL



418

CHAPA LAGRIMADA CL
PATTERNED METAL SHEETS CL

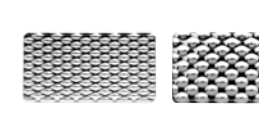

419

ACERO PLATA AG
STEEL SILVER AG



PLACAS DE ACERO RECTIFICADAS (longitud 500mm) PLRH PRECISION GROUND PLATES (500mm length) PLRH

Material: 1.2379

Dureza: Recocido blando ≤ 255 HB / Hardness: soft annealed ≤ 255 HB

Acabados / Finishes:

- H: Rectificado / Ground execution
- W: Fresado / Fine milled execution

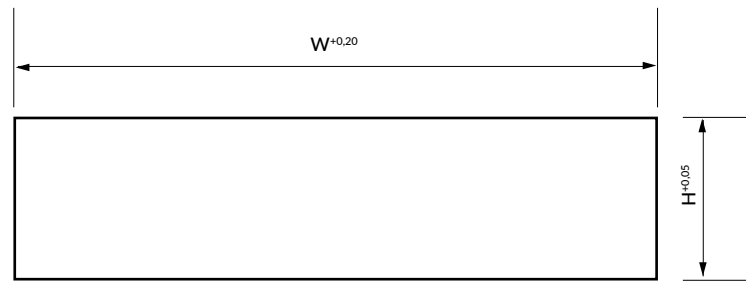

L: 500 mm ⁺⁵

		H Espesor - Thickness (mm)															
		2,2	3,2	4,2	5,2	6,2	8,2	10,2	12,2	15,2	20,4	25,4	30,4	40,4	50,4	60,4	80,4
W Ancho Width (mm)	5,2	-	-	-	•	-	-	-	-	-	-	-	-	-	-	-	-
	6,2	-	-	-	-	•	-	-	-	-	-	-	-	-	-	-	-
	8,2	-	-	-	-	-	•	-	-	-	-	-	-	-	-	-	-
	10,3	•	•	•	•	•	•	•	-	-	-	-	-	-	-	-	-
	12,3	•	•	•	•	•	•	•	•	-	-	-	-	-	-	-	-
	15,3	•	•	•	•	•	•	•	•	•	-	-	-	-	-	-	-
	20,3	•	•	•	•	•	•	•	•	•	•	-	-	-	-	-	-
	25,3	•	•	•	•	•	•	•	•	•	•	•	-	-	-	-	-
	30,3	•	•	•	•	•	•	•	•	•	•	•	•	-	-	-	-
	40,3	•	•	•	•	•	•	•	•	•	•	•	•	•	-	-	-
	50,3	•	•	•	•	•	•	•	•	•	•	•	•	•	•	-	-
	60,3	•	•	•	•	•	•	•	•	•	•	•	•	•	•	•	-
	75,3	•	•	•	•	•	•	•	•	•	•	•	•	•	•	•	-
	80,3	•	•	•	•	•	•	•	•	•	•	•	•	•	•	•	•
	100,3	•	•	•	•	•	•	•	•	•	•	•	•	•	•	•	-
	120,3	•	•	•	•	•	•	•	•	•	•	•	•	•	•	•	-
	125,3	•	•	•	•	•	•	•	•	•	•	•	•	•	•	•	-
	150,3	•	•	•	•	•	•	•	•	•	•	•	•	•	•	•	-
	200,3	•	•	•	•	•	•	•	•	•	•	•	•	•	•	•	-
	250,3	•	•	•	•	•	•	•	•	•	•	•	•	•	•	•	-
300,3	•	•	•	•	•	•	•	•	•	•	•	•	•	•	•	-	

Forma de pedido: PLRH + L*W*H
How to order: PLRH + L*W*H

PLACAS DE ACERO RECTIFICADAS (longitud 1000mm) PLRH
PRECISION GROUND PLATES (500mm length) PLRH

Material: 1.2379

Dureza: Recocido blando ≤ 255 HB / Hardness: soft annealed ≤ 255 HB

Acabados / Finishes:

- H: Rectificado / Ground execution
- W: Fresado / Fine milled execution

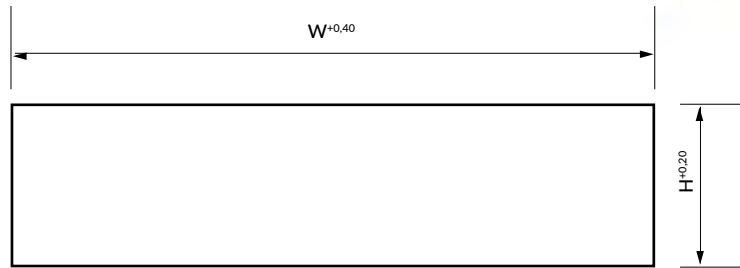

L: 1000 mm ⁺⁵⁻³⁰

		H Espesor - Thickness (mm)																					
		2,2	3,2	4,2	5,2	6,2	8,2	10,4	12,4	15,4	16,4	20,4	25,4	30,4	32,4	40,4	50,4	60,4	70,4	80,4	100,4	120	150
W Ancho Width (mm)	6,2	-	-	-	-	•	-	-	-	-	-	-	-	-	-	-	-	-	-	-	-	-	-
	8,2	-	-	-	-	-	•	-	-	-	-	-	-	-	-	-	-	-	-	-	-	-	-
	10,4	•	•	•	•	•	•	•	-	-	-	-	-	-	-	-	-	-	-	-	-	-	-
	12,4	-	-	-	-	-	-	-	•	-	-	-	-	-	-	-	-	-	-	-	-	-	-
	15,4	•	•	•	•	•	•	•	•	•	-	-	-	-	-	-	-	-	-	-	-	-	-
	16,4	-	-	-	-	-	-	-	-	-	•	-	-	-	-	-	-	-	-	-	-	-	-
	20,4	•	•	•	•	•	•	•	•	•	•	•	-	-	-	-	-	-	-	-	-	-	-
	25,4	•	•	•	•	•	•	•	•	•	•	•	•	-	-	-	-	-	-	-	-	-	-
	30,4	•	•	•	•	•	•	•	•	•	•	•	•	•	-	-	-	-	-	-	-	-	-
	32,4	•	•	•	•	•	•	•	•	•	•	•	•	•	•	-	-	-	-	-	-	-	-
	40,4	•	•	•	•	•	•	•	•	•	•	•	•	•	•	•	-	-	-	-	-	-	-
	50,4	•	•	•	•	•	•	•	•	•	•	•	•	•	•	•	•	•	-	-	-	-	-
	60,4	•	•	•	•	•	•	•	•	•	•	•	•	•	•	•	•	•	•	-	-	-	-
	63,4	•	•	•	•	•	•	•	•	•	•	•	•	•	•	•	•	•	•	-	-	-	-
	70,4	•	•	•	•	•	•	•	•	•	•	•	•	•	•	•	•	•	•	•	-	-	-
	80,4	•	•	•	•	•	•	•	•	•	•	•	•	•	•	•	•	•	•	•	•	-	-
	90,4	•	•	•	•	•	•	•	•	•	•	•	•	•	•	•	•	•	•	•	•	-	-
	100,4	•	•	•	•	•	•	•	•	•	•	•	•	•	•	•	•	•	•	•	•	•	-
	120,4	-	-	-	-	•	•	•	•	•	•	•	•	•	•	•	•	•	•	•	•	•	•
	125,4	•	•	•	•	•	•	•	•	•	•	•	•	•	•	•	•	•	•	•	•	•	-
130,4	-	-	-	-	-	-	-	-	-	•	•	•	•	•	•	•	•	-	-	-	-	-	
140,4	-	-	-	-	•	•	•	•	•	•	•	•	•	•	•	•	•	•	•	•	•	-	
150,4	-	-	-	•	•	•	•	•	•	•	•	•	•	•	•	•	•	•	•	•	•	•	
160,4	-	-	-	•	•	•	•	•	•	•	•	•	•	•	•	•	•	•	•	•	•	-	
180,4	-	-	-	-	•	•	•	•	•	•	•	•	•	•	•	•	•	•	•	•	•	-	
200,4	-	-	-	•	•	•	•	•	•	•	•	•	•	•	•	•	•	•	•	•	•	•	
250,4	-	-	-	•	•	•	•	•	•	•	•	•	•	•	•	•	•	•	•	•	•	-	
300,4	-	-	-	•	•	•	•	•	•	•	•	•	•	•	•	•	•	•	•	•	•	-	
405	-	-	-	-	-	-	-	-	•	•	•	•	•	•	•	•	•	•	•	•	•	-	
505	-	-	-	-	-	•	•	•	•	•	•	•	•	•	•	•	•	•	•	•	•	-	

Forma de pedido: PLRH + L*W*H
 How to order: PLRH + L*W*H

PLACAS DE ACERO RECTIFICADAS (longitud 500mm) PLRC
PRECISION GROUND PLATES (500mm length) PLRC

Material: 1.2510

Dureza: Recocido blando ≤ 229 HB / Hardness: soft annealed ≤ 229 HB

Acabados / Finishes:

- H: Rectificado / Ground execution
- W: Fresado / Fine milled execution

STOCK

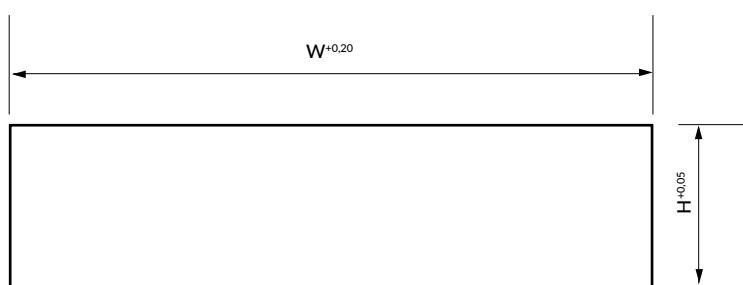

L: 500 mm ⁺⁵

		H Espesor / Thickness (mm)																							
		1	1,5	2	3	4	5	6	8	10	12	15	16	18	20	23	25	30	35	40	45	50	60	80	
W Ancho Width (mm)	4					•				-	-	-	-	-	-	-	-								
	5						•																		
	6	•	•	•	•	•	•	•	•	•	-	-	-	-	-	-	-	-							
	8	•	•	•	•	•	•	•	•	•															
	10	•	•	•	•	•	•	•	•	•	•														
	12	•	•	•	•	•	•	•	•	•	•	•													
	15	•	•	•	•	•	•	•	•	•	•	•	•												
	16													•											
	18	•	•	•	•	•	•	•	•	•	•	•	•		•										
	20	•	•	•	•	•	•	•	•	•	•	•	•		•	•									
	23																•								
	25	•	•	•	•	•	•	•	•	•	•	•	•		•	•		•							
	30	•	•	•	•	•	•	•	•	•	•	•	•		•	•		•	•	•					
	35	•	•	•	•	•	•	•	•	•	•	•	•		•	•		•	•		•				
	40	•	•	•	•	•	•	•	•	•	•	•	•		•	•		•	•		•	•			
	45	•	•	•	•	•	•	•	•	•	•	•	•		•	•		•	•		•	•		•	
	50	•	•	•	•	•	•	•	•	•	•	•	•		•	•		•	•		•	•		•	
	60	•	•	•	•	•	•	•	•	•	•	•	•		•	•		•	•		•	•		•	
	70	•	•	•	•	•	•	•	•	•	•	•	•		•	•		•	•		•	•		•	
	80	•	•	•	•	•	•	•	•	•	•	•	•		•	•		•	•		•	•		•	
	90	•	•	•	•	•	•	•	•	•	•	•	•		•	•		•	•		•	•		•	
	100	•	•	•	•	•	•	•	•	•	•	•	•		•	•		•	•		•	•		•	
	120	•	•	•	•	•	•	•	•	•	•	•	•		•	•		•	•		•	•		•	
	125	•	•	•	•	•	•	•	•	•	•	•	•		•	•		•	•		•	•		•	
	150	•	•	•	•	•	•	•	•	•	•	•	•		•	•		•	•		•	•		•	
160	•	•	•	•	•	•	•	•	•	•	•	•		•	•		•	•		•	•		•		
180	•	•	•	•	•	•	•	•	•	•	•	•		•	•		•	•		•	•		•		
200	•	•	•	•	•	•	•	•	•	•	•	•		•	•		•	•		•	•		•		
250	•	•	•	•	•	•	•	•	•	•	•	•		•	•		•	•		•	•		•		
300	•	•	•	•	•	•	•	•	•	•	•	•		•	•		•	•		•	•		•		
405						•	•	•	•	•	•	•		•	•		•	•		•	•		•		
505					•	•	•	•	•	•	•	•		•	•		•	•		•	•		•		

Forma de pedido: PLRC + L*W*H
 How to order: PLRC + L*W*H

PLACAS DE ACERO RECTIFICADAS (longitud 1000mm) PLRC
PRECISION GROUND PLATES (1000mm length) PLRC

Material: 1.2510

Dureza: Recocido blando ≤ 229 HB / Hardness: soft annealed ≤ 229 HB

Acabados / Finishes:

- H: Rectificado / Ground execution
- W: Fresado / Fine milled execution

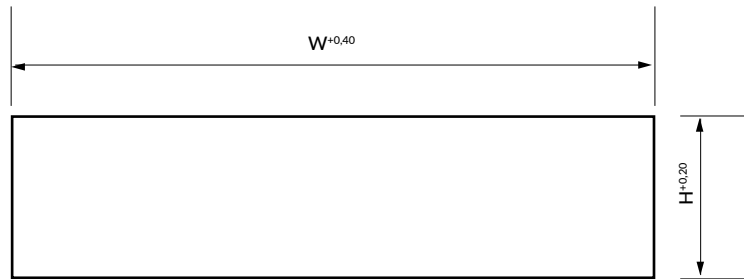
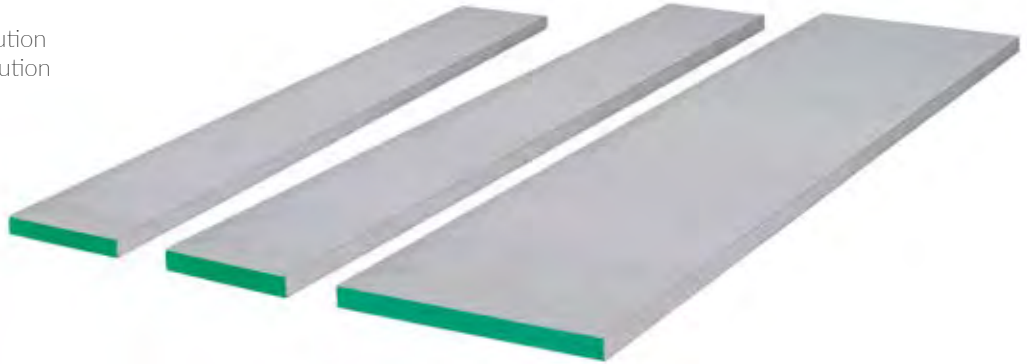

L: 1000 mm ⁺⁵⁻³⁰

W Ancho Width (mm)	H Espesor / Thickness (mm)																
	2	3	4	5	6	8	10	12	15	16	18	20	25	30	40	50	60
6	-	-	-	-	•	-	-	-	-	-	-	-	-	-	-	-	-
8	-	-	-	-	-	-	-	-	-	-	-	-	-	-	-	-	-
10	•	•	•	•	•	•	•	•	-	-	-	-	-	-	-	-	-
12	•	•	•	•	•	•	•	•	-	-	-	-	-	-	-	-	-
15	•	•	•	•	•	•	•	•	•	-	-	-	-	-	-	-	-
16	-	-	-	-	-	-	-	-	•	-	-	-	-	-	-	-	-
18	-	-	-	-	-	-	-	-	-	•	-	-	-	-	-	-	-
20	•	•	•	•	•	•	•	•	•	-	-	•	-	-	-	-	-
25	•	•	•	•	•	•	•	•	•	-	-	•	•	-	-	-	-
30	•	•	•	•	•	•	•	•	•	-	-	•	•	•	-	-	-
35	•	•	•	•	•	•	•	•	•	-	-	•	•	•	-	-	-
40	•	•	•	•	•	•	•	•	•	-	-	•	•	•	•	-	-
50	•	•	•	•	•	•	•	•	•	-	-	•	•	•	•	•	-
60	•	•	•	•	•	•	•	•	•	-	-	•	•	•	•	•	•
70	•	•	•	•	•	•	•	•	•	-	-	•	•	•	•	•	-
75	•	•	•	•	•	•	•	•	•	-	-	•	•	•	•	•	-
80	•	•	•	•	•	•	•	•	•	-	-	•	•	•	•	•	-
100	•	•	•	•	•	•	•	•	•	-	-	•	•	•	•	•	-
120	•	•	•	•	•	•	•	•	•	-	-	•	•	•	•	•	-
125	•	•	•	•	•	•	•	•	•	-	-	•	•	•	•	•	-
150	•	•	•	•	•	•	•	•	•	-	-	•	•	•	•	•	-
160	•	•	•	•	•	•	•	•	•	-	-	•	•	•	•	•	-
180	•	•	•	•	•	•	•	•	•	-	-	•	•	•	•	•	-
200	•	•	•	•	•	•	•	•	•	-	-	•	•	•	•	•	-
250	•	•	•	•	•	•	•	•	•	-	-	•	•	•	•	•	-
300	•	•	•	•	•	•	•	•	•	-	-	•	•	•	•	•	-

Forma de pedido: PLRC + L*W*H
 How to order: PLRC + L*W*H

CINTA CALIBRADA EN ROLLO GPR PRECISION FOIL ROLL GPR

STOCK



Material	Acero 1.1274 Steel				Inox 1.4310 Stainless					Latón 2.0321 Brass
Referencia / Reference	GPRA				GPRI					GPRL
Formato Format (mm)	6 x 5000	12,7 x 5000	25 x 5000	50 x 5000	12,7 x 5000	25 x 5000	50 x 5000	100 x 5000	150 x 5000	150 x 5000
Espesor Thickness (mm)										
0,005	-	-	-	-	•	-	•	•	-	-
0,01	-	•	-	-	•	•	•	•	-	•
0,015	-	-	-	-	-	-	-	•	-	-
0,02	-	•	-	-	•	•	•	•	-	•
0,025	-	-	-	-	-	-	-	-	•	•
0,03	-	•	•	•	•	-	•	•	-	•
0,035	-	-	-	-	-	-	-	-	-	-
0,04	-	•	•	•	•	-	•	•	-	•
0,045	-	-	-	-	-	-	-	-	-	-
0,05	•	•	•	•	•	•	•	•	•	•
0,055	-	-	-	-	-	-	-	-	-	-
0,06	-	•	•	•	•	-	-	•	-	-
0,07	-	•	•	•	•	-	-	•	-	-
0,075	-	-	-	-	-	-	-	-	•	•
0,08	•	•	-	•	•	-	-	•	-	-
0,09	-	•	•	•	•	-	-	•	-	-
0,1	•	•	•	•	•	•	•	•	•	•
0,15	•	•	•	•	•	•	•	•	•	•
0,2	•	•	•	•	•	•	•	•	•	•
0,25	•	•	•	•	•	•	•	•	•	•
0,3	•	•	•	•	•	•	•	•	•	•
0,35	-	•	-	•	•	-	-	•	-	-
0,4	•	•	•	•	•	•	•	•	•	•
0,45	-	•	-	•	•	-	-	•	-	-
0,5	-	•	•	•	•	•	•	•	•	•
0,55	-	•	-	-	-	-	-	•	-	-
0,6	-	•	•	•	•	•	•	•	•	•
0,65	-	•	-	-	-	-	-	•	-	-
0,7	-	•	•	•	•	•	•	•	•	•
0,75	-	•	-	-	-	-	-	•	-	-
0,8	-	•	•	•	•	•	•	•	•	•
0,85	-	•	-	-	-	-	-	•	-	-
0,9	-	•	•	•	•	•	•	•	•	•
0,95	-	•	-	-	-	-	-	•	-	-
1	-	•	•	•	•	•	•	•	•	•
1,5	-	-	-	-	-	-	-	-	-	-
2	-	-	-	-	-	-	-	-	-	-

Forma de pedido: Ref.+ Formato + Espesor
How to order: Ref. + Format + Thickness

CINTA CALIBRADA EN LÁMINAS GPL PRECISION FOIL SHEETS GPL

STOCK



Material	Acero 1.1274 Steel				Inox 1.4310 Stainless				Latón 2.0321 Brass
Referencia / Reference	GPLA				GPLI				GPLL
Uds. por Caja / Units per Package	10 Uds.	10 Uds.	1 Ud.	1 Ud.	5 Uds.	5 Uds.	1 Ud.	1 Ud.	5 Uds.
Formato Format (mm)	25 x 300	50 x 300	145 x 1000	300 x 1000	100 x 500	150 x 500	200 x 1000	300 x 1000	150 x 500
Espesor Thickness (mm)									
0,005	-	-	•	-	-	-	-	-	-
0,01	•	•	-	-	•	-	-	-	•
0,015	-	-	-	-	•	-	-	-	-
0,02	•	•	-	-	•	-	•	-	•
0,025	-	-	-	-	-	•	-	-	•
0,03	•	•	-	-	•	-	-	•	•
0,035	-	-	-	-	•	-	-	-	-
0,04	•	•	-	-	•	-	-	•	•
0,045	-	-	-	-	•	-	-	-	-
0,05	•	•	-	-	•	•	-	•	•
0,055	-	-	-	-	•	-	-	-	-
0,06	•	•	-	-	•	-	-	•	-
0,07	•	•	-	-	•	-	-	•	-
0,075	-	-	-	-	-	•	-	-	•
0,08	•	•	-	-	•	-	-	•	-
0,09	•	•	-	-	•	-	-	•	-
0,1	•	•	-	•	•	•	-	•	•
0,15	•	•	-	•	•	•	-	•	•
0,2	•	•	-	•	•	•	-	•	•
0,25	•	•	-	•	•	•	-	•	•
0,3	•	•	-	•	•	•	-	•	•
0,35	-	-	-	•	•	-	-	•	-
0,4	•	•	-	•	•	•	-	•	•
0,45	-	-	-	-	•	-	-	•	-
0,5	•	•	-	•	•	•	-	•	•
0,55	-	-	-	-	•	-	-	•	-
0,6	•	•	-	•	•	•	-	•	•
0,65	-	-	-	-	•	-	-	•	-
0,7	•	•	-	•	•	•	-	•	•
0,75	-	-	-	-	•	-	-	•	-
0,8	•	•	-	•	•	•	-	•	•
0,85	-	-	-	-	•	-	-	•	-
0,9	•	•	-	•	•	•	-	•	•
0,95	-	-	-	-	•	-	-	•	-
1	•	•	-	•	•	•	-	•	•
1,5	-	-	-	-	•	•	-	•	-
2	-	-	-	-	•	•	-	•	-

Forma de pedido: Ref.+ Formato + Espesor
How to order: Ref. + Format + Thickness

CHAPA LAGRIMADA CL PATTERNED METAL SHEETS CL

Material: Acero inoxidable 1.4016 / 1.4016 Stainless steel

STOCK

CL7

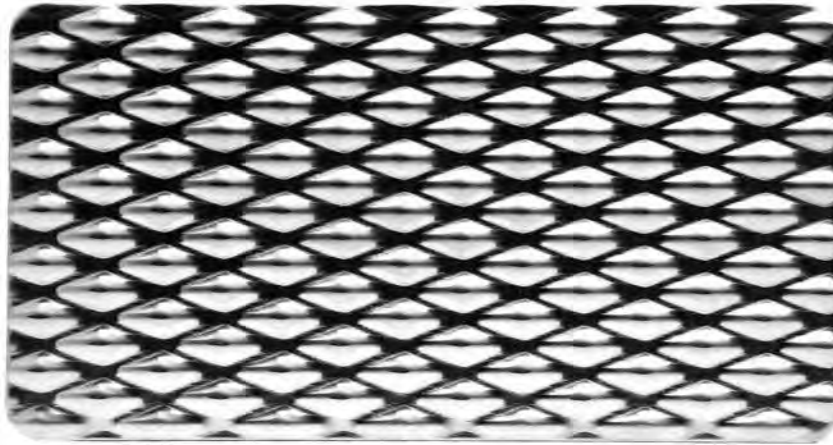

CL6

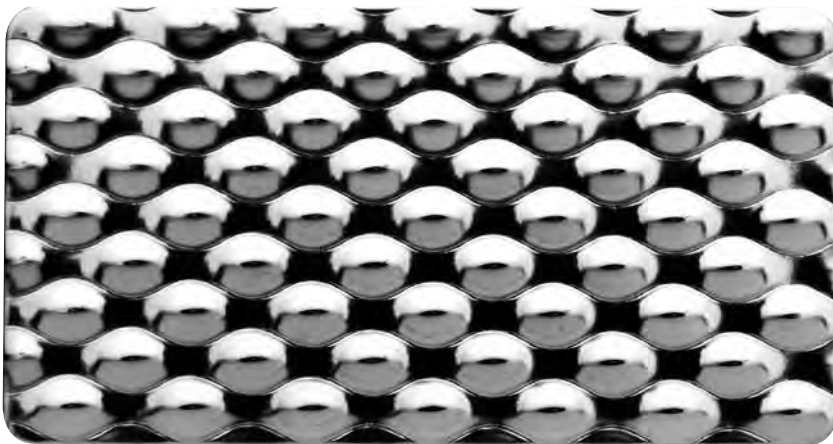

i Suministramos rampas a medida bajo pedido.
We supply ramps per drawing under demand.

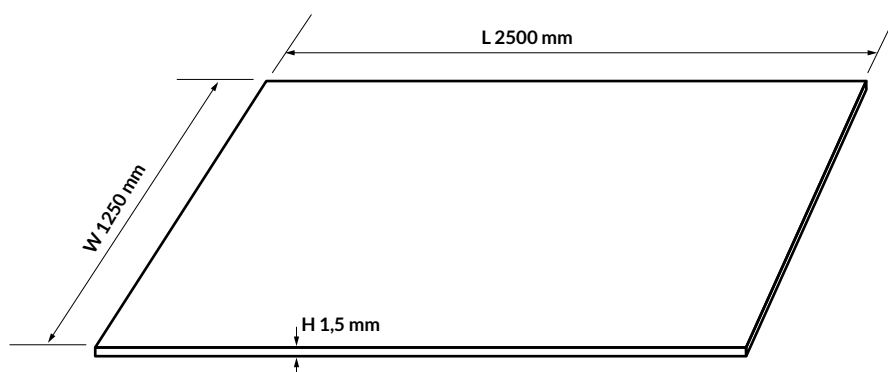

Forma de pedido: Ref.+ L*W*H
How to order: Ref. + L*W*H

ACERO PLATA AG STEEL SILVER AG

Material: 1.2210

Dureza: recocido blando ≤ 220 HB / Hardness: soft annealed ≤ 220 HB

STOCK

D (mm)	L (mm)	
	1000	2000
1	•	•
1,5	•	•
2	•	•
2,5	•	•
3	•	•
3,5	•	•
4	•	•
4,5	•	•
5	•	•
5,5	•	•
6	•	•
6,5	•	•
7	•	•
7,5	•	•
8	•	•
8,5	•	•
9	•	•
9,5	•	•
10	•	•
10,5	•	•
11	•	•
11,5	•	•
12	•	•
12,5	•	•
13	•	•
14	•	•
15	•	•
16	•	•
17	•	•
18	•	•
19	•	•
20	•	•
21	•	•
22	•	•
23	•	•
24	•	•
25	•	•
26	•	•
27	•	•
28	•	•
29	•	•
30	•	•
32	•	•
35	•	•
40	•	•
45	•	•
50	•	•

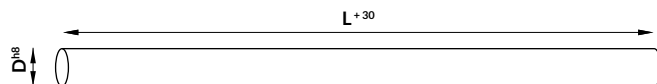

Forma de pedido: AG + D*L
How to order: AG + D*L

ELEMENTOS DE CENTRAJE Y DETECCIÓN CENTERING AND DETECTION ELEMENTS



En este apartado podrás encontrar diversos elementos diseñados para el centraje, posicionamiento y detección de los elementos móviles del troquel, como detectores, centradores, sensores, conectores, conos de centraje y muñequillas.

In this section you will find our selection of elements designed to centering, positioning and detecting the moving elements on the die, such as detectors, centering devices, sensors, connectors, centering cones and crank pins.

ELEMENTOS DE CENTRAJE Y DETECCIÓN

CENTERING AND DETECTION ELEMENTS

ÍNDICE INDEX

424

DETECTOR FC-1
FEEDCONTROL FC-1



425

DETECTOR FC-3
FEEDCONTROL FC-3



426

CENTRADOR EN L CLA
GAGE CLA



427

**CENTRADOR EN L TEMPLADO
CLT**
GAGE HARDENED CLT



428

CENTRADOR EN L SENSOR CLS
GAGE FOR SENSOR CLS



DIN 1451

429

SENSOR SEN
SENSOR SEN



430

CONECTOR CON
CONNECTOR CON



431

CONO DE CENTRAJE CCW
LOCATING CONE CCW



432

MUÑEQUILLA MQF
LOCATING PIN MQF



433

MUÑEQUILLA MQW
LOCATING PIN MQW



DETECTOR FC-1 FEEDCONTROL FC-1



i Este artículo se suministra con sensor y cable.
This article comes with sensor and cable.

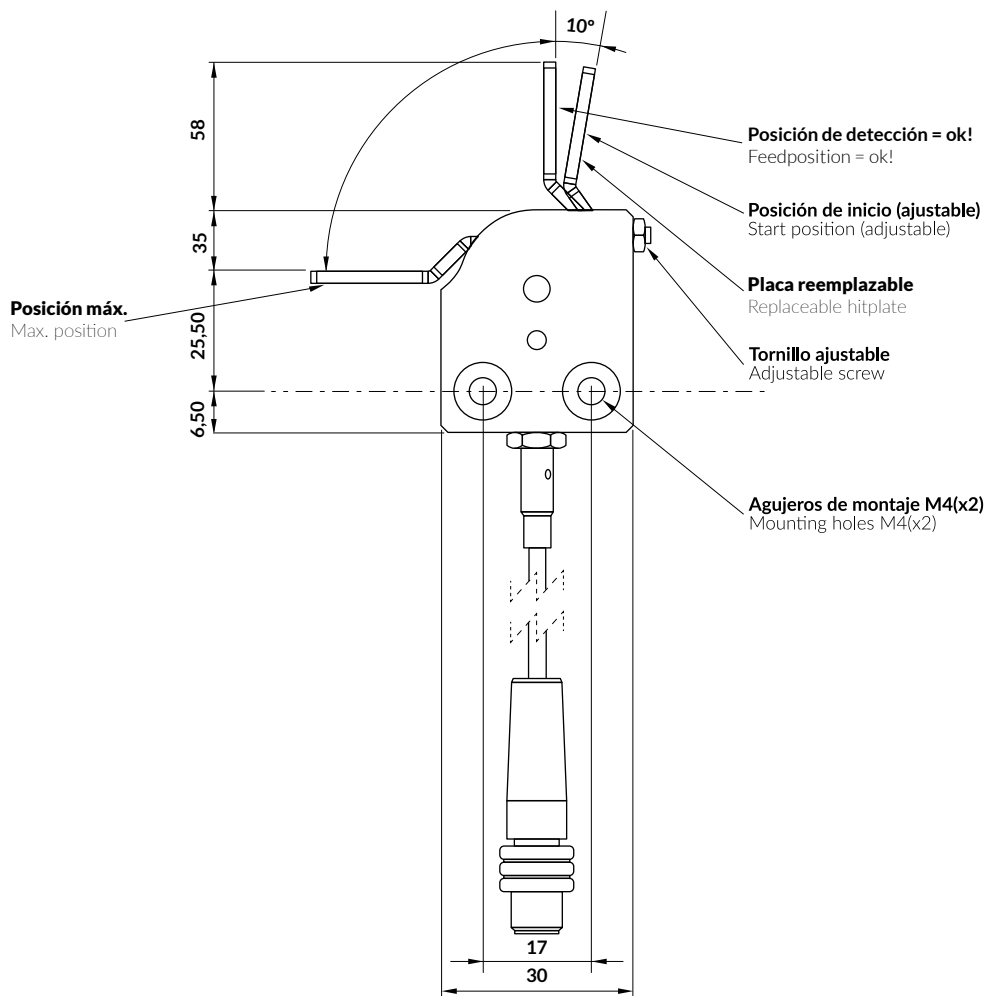

Forma de pedido: FC-1

How to order: FC-1
INDICE INDEX 

DETECTOR FC-3 FEEDCONTROL FC-3



i Este artículo se suministra con sensor y cable.
This article comes with sensor and cable.

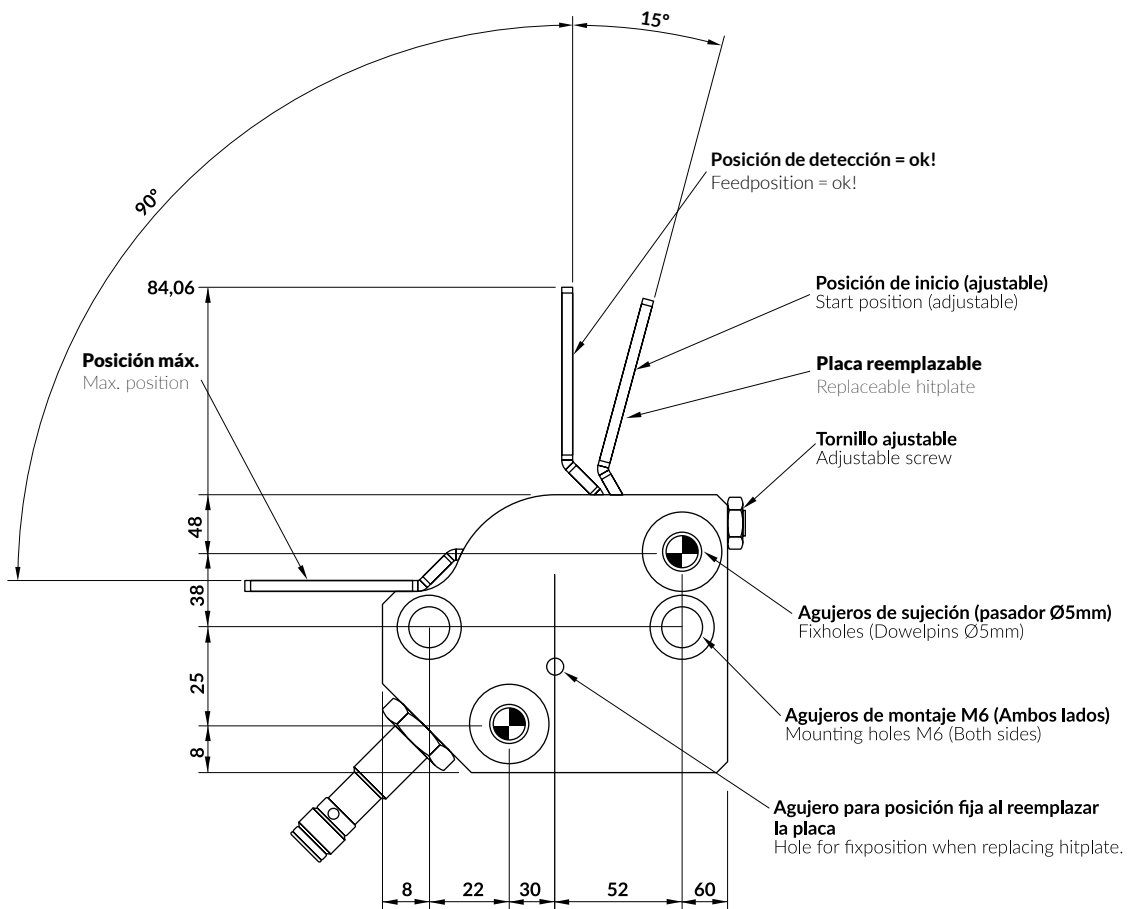

Forma de pedido: FC-3
How to order: FC-3

CENTRADOR EN L CLA GAGE CLA

Material: CK60

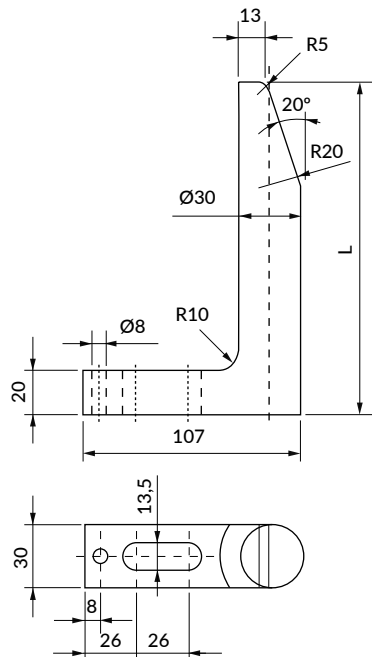

L					
65	105	145	185	225	280
70	110	150	190	230	290
75	115	155	195	235	300
80	120	160	200	240	310
85	125	165	205	245	320
90	130	170	210	250	330
95	135	175	215	260	340
100	140	180	220	270	350

Forma de pedido: CLA + L

How to order: CLA + L
 ÍNDICE
 INDEX

CENTRADOR EN L TEMPLADO CLT HARDENED GAGE CLT

Material: CK60

Dureza / Hardness: 56-60 HRC

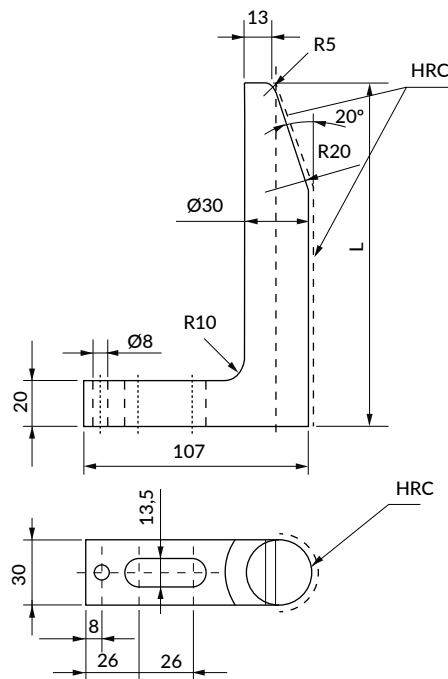

L					
65	105	145	185	225	280
70	110	150	190	230	290
75	115	155	195	235	300
80	120	160	200	240	310
85	125	165	205	245	320
90	130	170	210	250	330
95	135	175	215	260	340
100	140	180	220	270	350

Forma de pedido: CLT + L

How to order: CLT + L



CENTRADOR EN L PARA SENSOR CLS GAGE FOR SENSOR CLS

Material:

- ① CK60 - HRC: 50-55
- ② St37

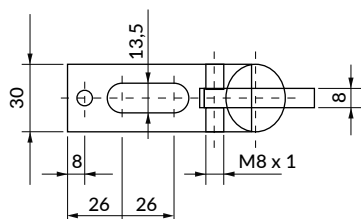
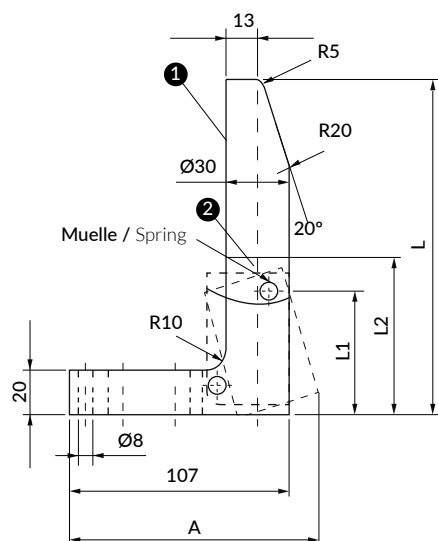

Ejemplo de aplicación / Application example

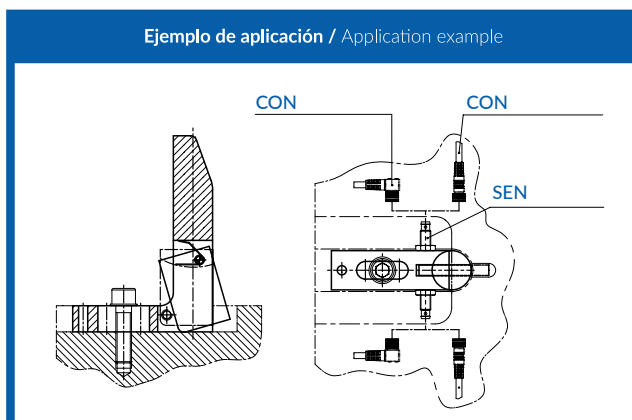

A	L	L1	L2
120	120	55	70
120	150	55	70
124	180	105	120
124	250	105	120

Forma de pedido: CLS + L

How to order: CLS + L

ÍNDICE
INDEX



SENSOR SEN

SENSOR SEN

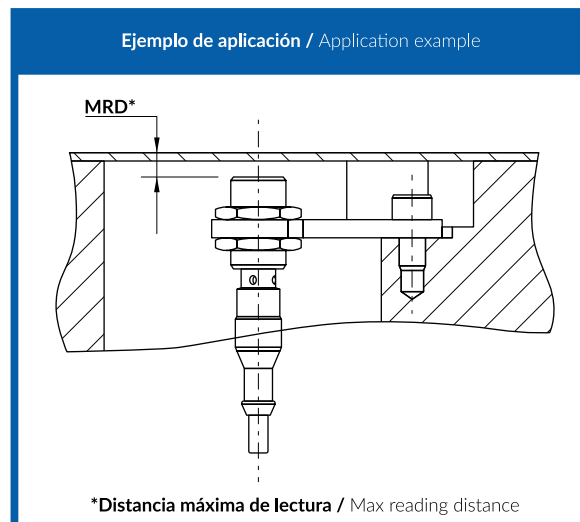
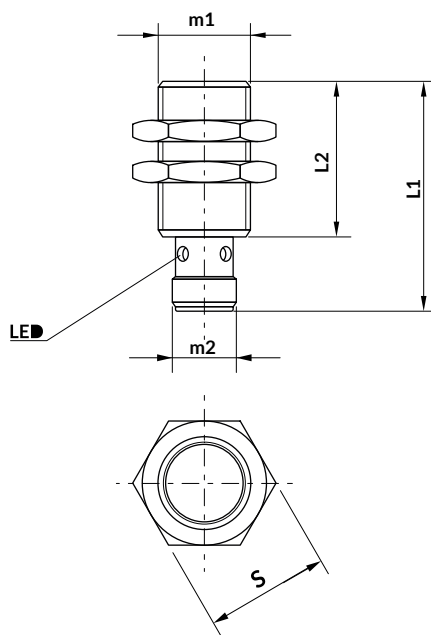

Referencia / Reference	L1	L2	m1	m2	S	MRD* en acero (mm) / on steel (mm)	MRD* en aluminio (mm) / on aluminium (mm)
SENM8	30	23,5	M8x1	M8x1	13	2	-
SENM12	45	30	M12x1	M12x1	17	4	-
SENM18	44,5	29,5	M18x1	M12x1	24	5	3
SENM30	44,5	30	M30x1,5	M12x1	36	10	6

Datos técnicos / Technical data	SENM8	SENM12	SENM18	SENM30
Tensión de funcionamiento nominal (Ue) / Rated operational voltage (Ue)	24 V DC	24 V DC	24 V DC	24 V DC
Tensión de alimentación (Ub) / Supply voltage (Ub)	10...30 V DC	10...30 V DC	10...30 V DC	10...30 V DC
Sin corriente de alimentación de carga (Io max.) / No load supply current (Io max.)	≤ 8 mA	≤ 10 mA	≤ 8 mA	≤ 12 mA
Corriente residual (Ir) / Residual current (Ir)	≤ 10 μA	≤ 50 μA	≤ 50 μA	≤ 80 μA
Exactitud de repetición (R) / Repeat accuracy (R)	≤ 5 %	≤ 5 %	≤ 5 %	≤ 5 %
Rango de temperatura ambiente (Ta) / Ambient temperature range (Ta)	-25...+70°C	-25...+85°C	-25...+70°C	25...+70°C
Frecuencia de ciclos de funcionamiento (f) / Frequency of operating cycles (f)	3000 Hz	2000 Hz	1000 Hz	200 Hz
Grado de protección según IEC 60529 / Degree of protection per IEC 60529	IP 67	IP 68	IP 67	IP 67
Material de la carcasa / Housing material	Acero inoxidable Stainless Steel	Acero inoxidable Stainless Steel	Acero inoxidable Stainless Steel	Acero inoxidable Stainless Steel
Conexión / Connection	Conector Connector	Conector Connector	Conector Connector	Conector Connector
Aprobación / Approval	UL	UL	UL	UL

* Distancia máxima de lectura / *Max reading distance



ÍNDICE
INDEX

Forma de pedido: SEN + m1
How to order: SEN + m1

CONECTOR CON CONNECTOR CON



FORMA A / FORM A

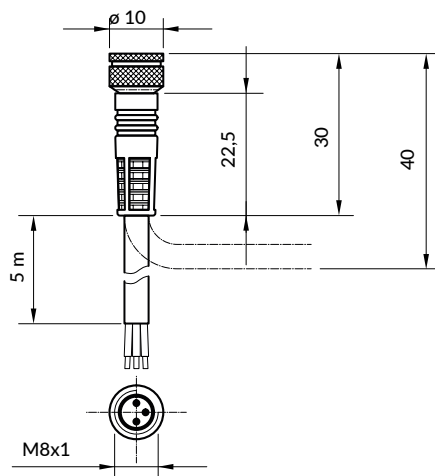

FORMA B / FORM B

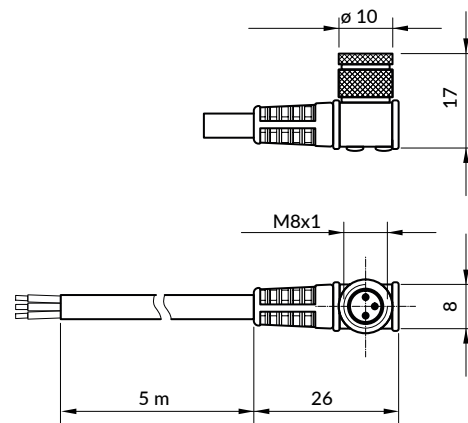

FORMA C / FORM C

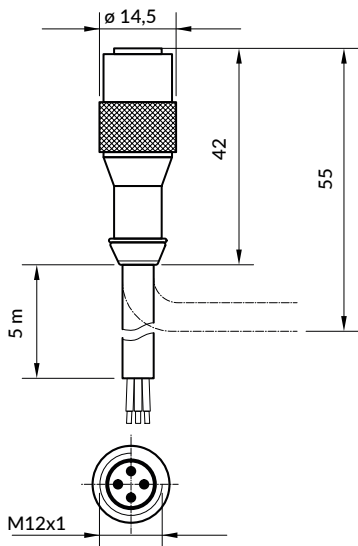

FORMA D / FORM D

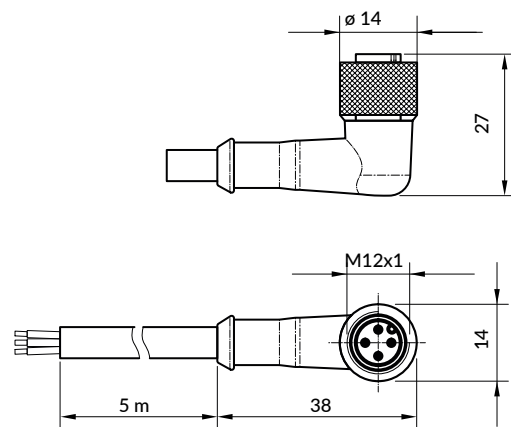

Referencia / Reference	Forma / Form
CON-A	A
CON-B	B
CON-C	C
CON-D	D

Forma de pedido: CON + Forma
How to order: CON + Form

ÍNDICE
INDEX



CONO DE CENTRAJE CCW
LOCATING CONE CCW

Material:

Cono / Cone: 1.7131 - HRC: 60-62

Sufridera / Backing plate: 1.1191

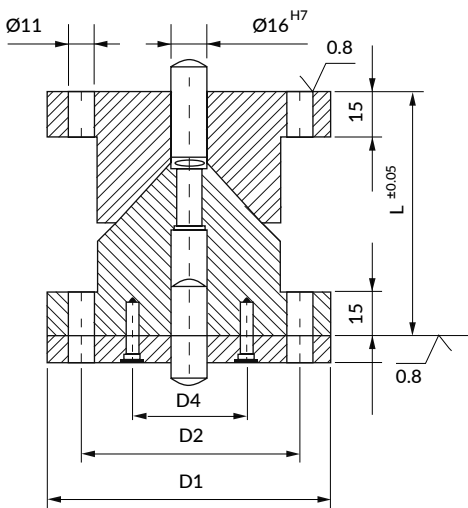

Forma / Form A

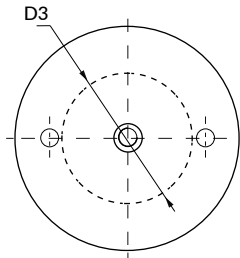

Forma / Form B

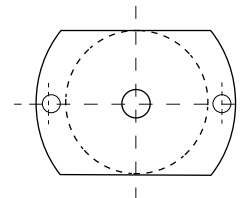

Forma / Form C

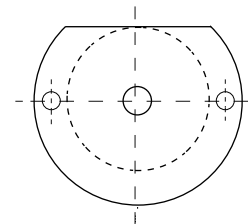

D1	D2	D3	D4	L	H	Forma / Form
100	76	58	40,5	80	10	A, B, C
120	96	78	50,5	90		

Forma de pedido: CCW + D1 + Forma

How to order: CCW + D1 + Form



MUÑEQUILLA MQF LOCATING PIN MQF

Material: 1.7131

Dureza / Hardness: 58-60 HRC

STOCK

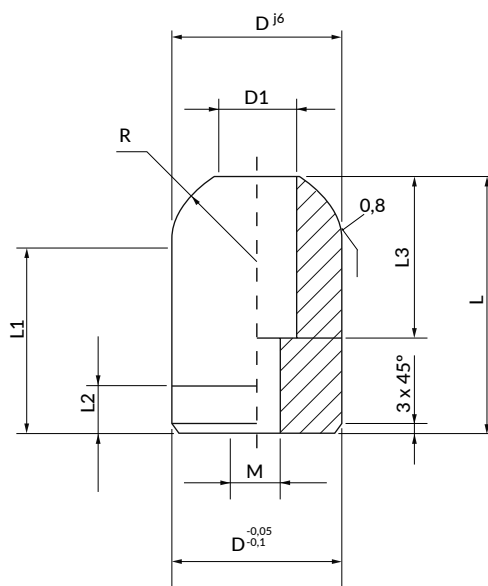

D	D1	L	L1	L2	L3	M	R
22	14	45	37,5	8	25	M10	12,5
32	18	50	40	10	35	M12	20
40	18	55	40	10	35	M12	20
50	18	55	40	10	35	M12	20

Forma de pedido: MQF + D*L

How to order: MQF
INDICE
INDEX



MUÑEQUILLA MQW LOCATING PIN MQW

Material: 1.7131

Dureza / Hardness: 58-60 HRC

STOCK

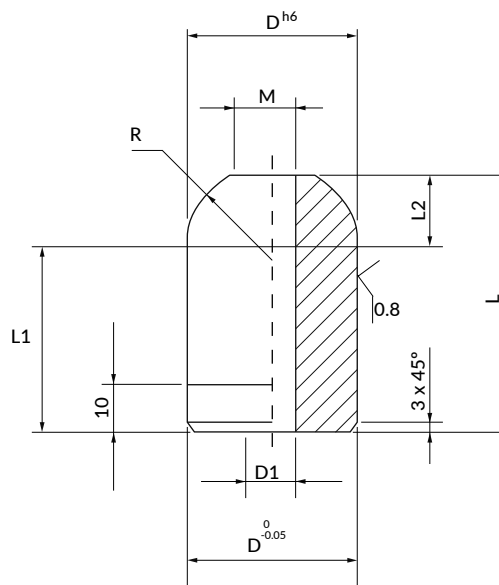

D	D1	L	L1	L2	M	R
22	7	45	35	16	M8	15
22	7	55	45	16	M8	15
32	9	50	37,5	20	M10	20
40	9	55	35	20	M10	25
40	9	65	45	20	M10	25
40	9	85	65	20	M10	25
50	9	55	41,25	20	M10	25
56	9	80	60	20	M10	30

Forma de pedido: MQW + D*L

How to order: MQW + D*L



ÍNDICE
INDEX

CARROS CAM UNITS



Ofrecemos una amplia gama de carros de varias geometrías y dimensiones, que han sido diseñados y producidos para poder hacer frente a la mayoría de exigencias técnicas. Destacamos la serie Star Cam (CHD, CHV, CLB, CRX y DHC), que se caracteriza por su alto nivel de rendimiento, competitividad, servicio y plazos de entrega.

Diseñamos y fabricamos carros especiales, y hacemos mecanizados adicionales a carros normalizados, según diseños especiales y necesidades particulares de producción.

We offer a wide range of cam units in various forms and dimensions, which are designed and produced to satisfy most technical requirements. The Star Cam Series (CHD, CHV, CLB, CRX and DHC), represents the best characteristics of performance, competitiveness and service. The cam units from this Series offer the maximum quality and short delivery times for replacements.

We also design and produce special cam units, or make additional workings on normalized cam units, in order to meet every customer's particular production needs.

CARROS CAM UNITS

ÍNDICE INDEX

438

GAMA COMPLETA
GAMA COMPLETA

-

439

CARROS AÉREOS CHD
AERIAL CAM UNITS CHD



-

440

CARROS AÉREOS CHV
AERIAL CAM UNITS CHV



-

441

CARROS AÉREOS CLB
AERIAL CAM UNITS CLB



-

442

CARROS DE RODILLO CRX
ROLLER CAM UNITS CRX



-

443

CARROS DE BASE INFERIOR DHC
DIE MOUNTED CAM UNIT DHC



-

444

CARROS ESPECIALES
SPECIAL CAM UNITS



-

445

CARROS PERSONALIZADOS
CUSTOMIZED CAM UNITS



-

RESUMEN GAMA RANGE OVERVIEW

CARROS AÉREOS / AERIAL CAM UNITS

CARGA FUERTE HEAVY DUTY

CHD CHR CHV CHY CLB



CARGA LIGERA LIGHT DUTY

CHK CLC CLD CLF CLK



CARROS DE RODILLO / ROLLER CAM UNITS

CARGA FUERTE HEAVY DUTY

DCRX

CRX



CARROS DE BASE INFERIOR / DIE MOUNTED CAM UNITS

CARGA FUERTE HEAVY DUTY

DHC



CARGA LIGERA LIGHT DUTY

DLD



Norma / Standard: NAAMS - VDI

CARROS AÉREOS CHD AERIAL CAM UNITS CHD



La gama CHD es adecuada para trabajos de carga fuerte. Disponemos de nueve modelos con ángulos de trabajo desde 0° hasta 65° (en intervalos de 5°), fuerza de trabajo desde 60 hasta 645 kN, y bancadas útiles desde 50 hasta 300 mm. Posibilidad de elegir el retorno con muelle o cilindro de nitrógeno.

We recommend the CHD range of cam units for heavy-duty applications. Nine models are available with work angles from 0° to 65° (in 5° steps), work forces from 60 to 645 kN, slider widths from 50 to 300 mm. It is possible to choose between coil spring or gas spring return.

Código Code	Ángulo de trabajo Work angle β	Bancada Slider width (mm)	Alto carro cerrado Closed cam height (mm)	Área de trabajo Work area W x H (mm)	Máx. fuerza de trabajo Max. work force width	Fuerza de extracción Extraction force	
					10° ciclos /cycles (kN)	(kN)	
					F _s	Muelle Spring	Cilindro Gas spring
CHD050	0°÷65° (5° steps)	50	180	50x65	60	1,14÷1,31	1,44÷1,72
CHD065	0°÷65° (5° steps)	65	180	65x65	60	1,14÷1,31	1,44÷1,72
CHD080	0°÷65° (5° steps)	80	275	80x88	149	1,13÷1,37	1,50÷1,85
CHD100	0°÷65° (5° steps)	100	275	100x88	149	1,13÷1,37	1,50÷1,85
CHD150	0°÷65° (5° steps)	150	355	150x120	391	2,29	7,15
CHD180	0°÷65° (5° steps)	180	355	180x120	396	2,29	7,15
CHD200	0°÷65° (5° steps)	200	355	200x120	396	2,29	7,15
CHD250	0°÷65° (5° steps)	250	355	250x160	645	4,58	14,30
CHD300	0°÷65° (5° steps)	300	355	300x160	645	4,58	14,30

Tabla resumen. Para más información, ver royme.com
General data. For further information go to royme.com

CARROS AÉREOS CHV AERIAL CAM UNITS CHV



Los carros CHV representan el TOP de la gama completa. Compactos, con una gran fuerza de trabajo y de retorno, y una gran resistencia a la torsión, son indicados para trabajos que requieren de una gran precisión de penetración. Se caracterizan por su fácil mantenimiento gracias al uso de placas normalizadas (VDI3357) y la posibilidad de cambio de cilindros de nitrógeno en troquel. Disponemos de once modelos con ángulos de trabajo desde 0° hasta 75° (en intervalos de 5°), fuerza de trabajo desde 92 hasta 1202 kN, y bancadas útiles desde 50 hasta 600 mm

They are compact, have high work and return forces, are built from high-strength materials which ensure excellent resistance to twisting loads and have very good penetrating precision. They are characterized by easy maintenance thanks to the use of normalized wear plates (VDI3357) and to the possibility to change the gas spring under press. Twelve models are available with work angles from 0° to 75° (in 5° steps), work forces from 92 to 1202 kN, slider widths from 50 to 600 mm.

Código Code	Ángulo de trabajo Work angle β	Bancada Slider width (mm)	Alto carro cerrado Closed cam height (mm)	Área de trabajo Work area W x H (mm)	Máx. fuerza de trabajo Max. work force width 10° ciclos /cycles (kN)	Fuerza de extracción Extraction force (kN)
					Fs	Ef
					Cilindro Gas spring	
CHV050	0°÷75° (5° steps)	50	175÷195	60x100	92÷110	4,5÷6,1
CHV060	0°÷75° (5° steps)	60	210	60x100	136÷143	5,1÷6,2
CHV085	0°÷75° (5° steps)	85	225	85x120	229÷293	7,10÷12
CHV110	0°÷75° (5° steps)	110	275	110x160	357÷407	6,2÷16,8
CHV150	0°÷75° (5° steps)	150	300	150x160	421÷584	17,3÷20,8
CHV180	0°÷75° (5° steps)	180	300	180x160	474÷598	17,1÷20,5
CHV220	0°÷75° (5° steps)	220	300	220x160	635÷732	16,6÷46,2
CHV260	0°÷75° (5° steps)	260	300	260x160	536÷767	16,6÷46,2
CHV330	0°÷75° (5° steps)	330	375	330x180	1005÷1020	46,5÷94,9
CHV400	0°÷75° (5° steps)	400	375	400x180	1052÷1055	48÷87,1
CHV500	0°÷75° (5° steps)	500	375	500x180	1155	64,5÷87,0
CHV600	0°÷75° (5° steps)	600	400	600x200	1202	84,2÷98,2

Tabla resumen. Para más información, ver royme.com
General data. For further information go to royme.com

CARROS AÉREOS CLB AERIAL CAM UNITS CLB



Robustos y compactos, los carros CLB ofrecen una excelente relación calidad-precio. Disponemos de cinco modelos con ángulos de trabajo desde 0° hasta 60° (en intervalos de 5°), fuerza de trabajo desde 302 hasta 865 kN, y bancadas útiles desde 200 hasta 600 mm. Posibilidad de elegir el retorno con muelle o cilindro de nitrógeno.

Our CLB cam units offer a very competitive performance /price ratio. Five models are available with work angles from 0° to 60° (in 5° steps), work forces from 302 to 865 kN, slider widths from 200 to 600 mm. It is possible to choose between coil spring or gas spring return.

Código Code	Ángulo de trabajo Work angle β	Bancada Slider width (mm)	Alto carro cerrado Closed cam height (mm)	Área de trabajo Work area W x H (mm)	Máx. fuerza de trabajo Max. work force width	Fuerza de extracción Extraction force	
					10 ⁶ ciclos /cycles (kN)	(kN)	
					F _s	Muelle Spring	Cilindro Gas spring
CLB200	0°÷60° (5° steps)	200	350	200x180	302	2,12÷2,73	8,88÷11,42
CLB300	0°÷60° (5° steps)	300	350	300x180	411	4,25÷5,46	17,76÷22,83
CLB400	0°÷60° (5° steps)	400	350	400x180	526	4,25÷5,46	17,76÷22,83
CLB500	0°÷60° (5° steps)	500	350	500x180	743	6,37÷8,19	26,64÷34,25
CLB600	0°÷60° (5° steps)	600	350	600x180	865	8,50÷10,92	35,52÷45,67

Tabla resumen. Para más información, ver royme.com
General data. For further information go to royme.com

CARROS DE RODILLO CRX ROLLER CAM UNITS CRX



Gracias a su tamaño compacto, los carros CRX son especialmente indicados para aplicaciones con poco espacio entre agujeros. Sus principales puntos fuertes son la facilidad de montaje y la flexibilidad. Disponemos de cinco modelos con ángulos de trabajo desde -15° (punzonado con ángulos negativos) hasta 50° (aplicables en todos los grados intermedios), fuerzas de trabajo desde 45 hasta 258 kN, y bancadas útiles desde 78 hasta 240 mm. Carreras de 30 y 50 mm para CRX01, de 50, 80 y 100 mm para el resto de modelos. Nuevos ganchos de seguridad para la extracción. Cuñas de accionamiento normalizadas para ángulos de trabajo de -15° a 50° (en intervalos de 5°).

Thanks to their compact size, CRX cam units are particularly suited for close punching. Ease of mounting and flexibility in applications are their strong points. Five models are available with work angles from -15° (back-draft punching) to 50° (free angle steps), work forces from 45 to 258 kN, slider widths from 78 to 240 mm. Strokes 30 and 50 available for CRX01, 50, 80 and 100 mm for other models. New positive returns for extraction. Normalized wedges with work angles from -15° to 50° (in 5° steps).

Código Code	Ángulo de trabajo Work angle β	Bancada Slider width (mm)	Área de trabajo Work area W x H (mm)	Carrera Stroke (mm)	Máx. fuerza de trabajo Max. work force width	Fuerza de extracción Extraction force
					10 ⁶ ciclos /cycles (kN)	(kN)
					F _s	E _f Cilindro Gas spring
CRX01	$-15^\circ \div 50^\circ$ (5 steps)	78	78x63	30, 50	45	2,5÷3,4
CRX03	$-15^\circ \div 50^\circ$ (5 steps)	98	98x63	50, 80, 100	76	3,4÷3,6
CRX05	$-15^\circ \div 50^\circ$ (5 steps)	118	118x74	50, 80, 100	142	6,36÷6,46
CRX15	$-15^\circ \div 50^\circ$ (5 steps)	170	170x94	50, 80, 100	166	6,45÷6,61
CRX20	$-15^\circ \div 50^\circ$ (5 steps)	240	240x110	50, 80, 100	258	9,29÷9,38

Tabla resumen. Para más información, ver royme.com
General data. For further information go to royme.com

CARROS DE BASE INFERIOR DHC DIE MOUNTED CAM UNIT DHC



Los carros DHC de base inferior son idóneos para trabajos pesados de punzonado y plegado gracias a la estructura de fundición esferoidal. Garantizan un mejor mantenimiento gracias al uso de placas de bronce+grafito/acero en las zonas de guiado más comprometidas. Disponemos de siete modelos con fuerzas de trabajo desde 38 hasta 480 kN, bancadas útiles desde 52 hasta 400 mm, y ángulo de trabajo de 0° para bancadas de 52, 200, 250, 300 y 400 mm, y de 0° a 20° (en intervalos de 5°) para bancadas útiles de 65, 100 y 150 mm. Posibilidad de retorno con cilindro.

DHC die mounted cam units are best suited for heavy drilling and flanging thanks to their spheroid cast iron structure. They are characterized by easy maintenance thanks to the use of self-lubricating wear plates and steel on the most stressed parts. Seven models are available with work forces from 38 to 480kN, slider widths from 52 to 400 mm, work angles 0° for 52, 200, 250, 300 and 400 mm widths, work angles from 0° to 20° (in 5° steps) for 65, 100 and 150 mm widths. Return by coil spring or gas spring.

Código Code	Ángulo de trabajo Work angle β	Bancada Slider width (mm)	Alto carro cerrado Closed cam height (mm)	Área de trabajo Work area W x H (mm)	Carrera Stroke (mm)	Máx. fuerza de trabajo Max. work force width 10 ⁶ ciclos /cycles (kN)	Fuerza de extracción Extraction force (kN)	
						Fs	Muelle Spring	Cilindro Gas spring
							Ef	
DHC052	0°	52	140	52x65	25, 40, 60	38	0,62÷0,65	-
DHC065	0÷20° (5 steps)	65	160, 170	65x70	40, 45, 60, 70	44÷48	0,78÷1,02	-
DHC100	0÷20° (5 steps)	100	200	100x100	40, 45, 60, 70, 80	75÷82	-	4,6÷6,1
DHC150	0÷20° (5 steps)	150	220, 230	150x100	40, 45, 60, 70	120÷127	-	4,6÷6,6
DHC200	0°	200	240	200x110	40, 60	176	-	8,6÷10,1
DHC250	0°	250	270	250x130	40, 60	232	-	8,6÷9,4
DHC300	0°	300	270	300x130	40, 60	272	-	8,6÷9,4
DHC400	0°	400	250	400x150	60	480	-	25,2





Tabla resumen. Para más información, ver royme.com
General data. For further information go to royme.com

CARROS PERSONALIZADOS: CARRO ESTÁNDAR CON MECANIZADO ESPECIAL

CUSTOMIZED CAM UNITS: STANDARD CAM UNIT WITH ADDITIONAL WORKING

Los carros se pueden suministrar personalizados. La personalización permite reducir el tiempo de montaje en troquel, liberando recursos de la máquina y permitiendo al usuario centrarse en otras actividades de construcción del troquel. El cliente debe aportar su mecanizado en formato CAD 3D, al menos 10 días antes de la fecha de entrega deseada. Consúltenos para más información.

Cam units can be supplied customized. The customizations allow to reduce cam units insertion time in the die, freeing machine resources and allowing the user to focus on other die construction activities. The machining are transmitted by the customer in 3D CAD format, at least 10 days in advance on the delivery date. Contact us for more information.

Descadados Highlights	
	Reducción de tiempo de montaje en troquel Reduction of cam unit assembly time in die
	Gestión de datos 3D CAD en formatos: CATIA V5 / PARASOLID / IGES 3D CAD data management in formats: CATIA V5 / PARASOLID / IGES
	Gran precisión en trabajos adicionales High precision in additional workings realization
	Reducción de costes de procesamiento Reduction of processing costs

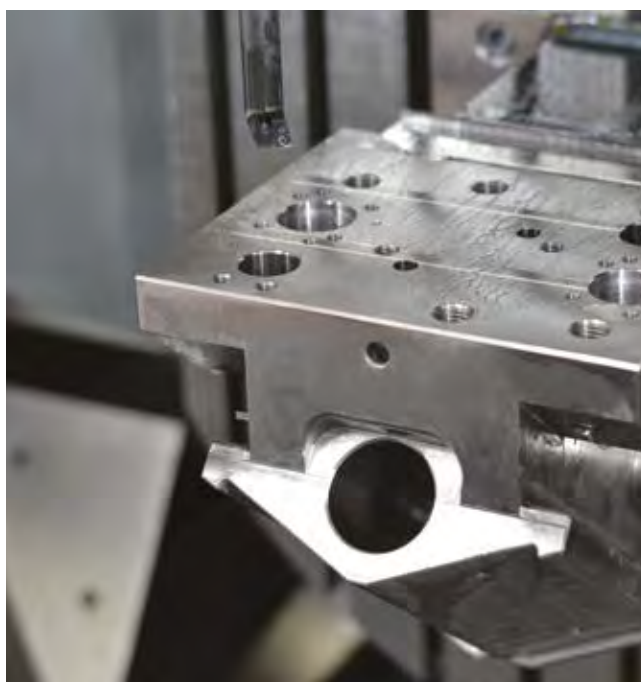

Forma de pedido: Consúltenos
How to order: Contact us

CARROS ESPECIALES SPECIAL CAM UNITS

Gracias a la enorme experiencia adquirida, también ofrecemos la opción de diseñar y fabricar carros especiales o múltiples según diseños especiales y necesidades particulares de producción. Además, se pueden solicitar mecanizaciones adicionales a carros normalizados. Las imágenes en esta página muestran algunas soluciones llevadas a cabo.

Thanks to the acquired experience in the manufacture of its wide range of cam units, we offer special or multiple cam units to meet every customer's particular production needs. Moreover, it is possible to ask for additional workings on normalized cam units. The images on this Page show some examples of a variety of solutions achievable.

CARRO DE BASE INFERIOR CON BANCADA DE 700MM DIE MOUNTED CAM UNIT WITH 700MM SLIDER WIDTH



CARROS CON MECANIZADO ADICIONAL EN PLACA CAM UNITS WITH ADDITIONAL WORKINGS ON SLIDER

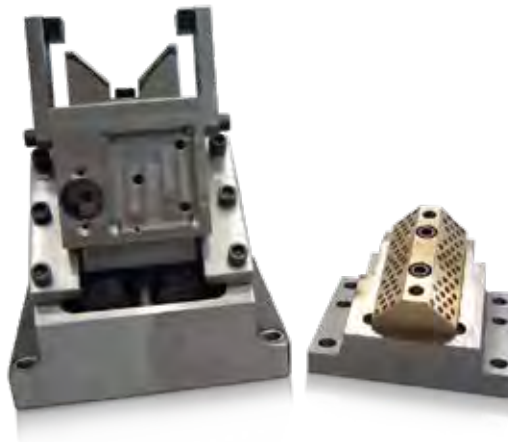

CARRO AÉREO MÚLTIPLE MULTIPLE AERIAL CAM UNIT



Forma de pedido: Consúltenos
How to order: Contact us

INFORMACIÓN TÉCNICA
TECHNICAL DATA

INFORMACIÓN TÉCNICA

TECHNICAL DATA

TOLERANCIAS PARA DIÁMETROS INTERIORES TOLERANCES FOR INSIDE DIAMETERS

Tolerancias ISO 286-2 para diámetros interiores / ISO 286-2 Tolerances for inside diameters (micron / 0,001 mm)

>	0	3	6	10	18	30	40	50	65	80	100
≤	3	6	10	18	30	40	50	65	80	100	120
E6	+20 +14	+28 +20	+34 +25	+43 +32	+53 +40	+66 +50	+66 +50	+76 +50	+76 +50	+94 +72	+94 +72
E7	+24 +14	+32 +20	+40 +25	+59 +32	+73 +40	+89 +50	+89 +50	+106 +60	+106 +60	+125 +72	+125 +72
E8	+28 +14	+38 +20	+47 +25	+50 +32	+61 +40	+75 +50	+75 +50	+90 +60	+90 +60	+107 +72	+107 +72
E11	+74 +14	+95 +20	+115 +25	+142 +32	+170 +40	+210 +50	+210 +50	+250 +60	+250 +60	+292 +72	+292 +72
E12	+114 +14	+140 +20	+175 +25	+212 +32	+250 +40	+300 +50	+300 +50	+360 +60	+360 +60	+422 +72	+422 +72
E13	+154 +14	+200 +20	+245 +25	+302 +32	+370 +40	+440 +50	+440 +50	+520 +60	+520 +60	+612 +72	+612 +72
F6	+12 +6	+18 +10	+22 +13	+27 +16	+33 +20	+41 +25	+41 +25	+49 +30	+49 +30	+58 +36	+58 +36
F7	+16 +6	+22 +10	+28 +13	+34 +16	+41 +20	+50 +25	+50 +25	+60 +30	+60 +30	+71 +36	+71 +36
F8	+20 +6	+28 +10	+35 +13	+43 +16	+53 +20	+64 +25	+64 +25	+76 +30	+76 +30	+90 +36	+90 +36
G6	+8 +2	+12 +4	+14 +5	+17 +6	+20 +7	+25 +9	+25 +9	+29 +10	+29 +10	+32 +12	+32 +12
G7	+12 +2	+16 +4	+20 +5	+24 +6	+28 +7	+34 +9	+34 +9	+40 +10	+40 +10	+47 +12	+47 +12
G8	+16 +2	+22 +4	+27 +5	+33 +6	+40 +7	+48 +9	+48 +9	+56 +10	+56 +10	+66 +12	+66 +12
H3	+2 +0	+2,5 0	+2,5 0	+3 0	+4 0	+4 0	+4 0	+5 0	+5 0	+6 0	+6 0
H5	+4 +0	+5 0	+6 0	+8 0	+9 0	+11 0	+11 0	+13 0	+13 0	+15 0	+15 0
H6	+6 +0	+8 0	+9 0	+11 0	+13 0	+16 0	+16 0	+19 0	+19 0	+22 0	+22 0
H7	+10 +0	+12 0	+15 0	+18 0	+21 0	+25 0	+25 0	+30 0	+30 0	+35 0	+35 0
H8	+14 +0	+18 0	+22 0	+27 0	+33 0	+39 0	+39 0	+46 0	+46 0	+54 0	+54 0
H9	+25 +0	+30 0	+36 0	+43 0	+52 0	+62 0	+62 0	+74 0	+74 0	+87 0	+87 0
H10	+40 +0	+48 0	+58 0	+70 0	+84 0	+100 0	+100 0	+120 0	+120 0	+140 0	+140 0
H11	+60 +0	+75 0	+90 0	+110 0	+130 0	+160 0	+160 0	+190 0	+190 0	+220 0	+220 0

TOLERANCIAS PARA DIÁMETROS INTERIORES
TOLERANCES FOR INSIDE DIAMETERS

>	0	3	6	10	18	30	40	50	65	80	100
≤	3	6	10	18	30	40	50	65	80	100	120
J6	+2 -4	+5 -3	+5 -4	+6 -5	+8 -5	+10 -6	+10 -6	+13 -6	+13 -6	+16 -6	+16 -6
J7	+4 -6	+6 -6	+8 -7	+10 -8	+12 -9	+14 -11	+14 -11	+18 -12	+18 -12	+22 -13	+22 -13
J8	+6 -8	+10 -8	+12 -10	+15 -12	+20 -13	+24 -15	+24 -15	+28 -18	+28 -18	+34 -20	+34 -20
JS5	+2 -2	+2,5 -2,5	+3 -3	+4 -4	+4,5 -4,5	+5,5 -5,5	+5,5 -5,5	+6,5 -6,5	+6,5 -6,5	+7,5 -7,5	+7,5 -7,5
JS6	+3 -3	+4 -4	+4,5 -4,5	+5,5 -5,5	+6,5 -6,5	+8 -8	+8 -8	+9,5 -9,5	+9,5 -9,5	+11 -11	+11 -11
JS7	+5 -5	+6 -6	+7,5 -7,5	+9 -9	+10,5 -10,5	+12,5 -12,5	+12,5 -12,5	+15 -15	+15 -15	+17,5 -17,5	+17,5 -17,5
JS8	+7 -7	+9 -9	+11 -11	+13,5 -13,5	+16,5 -16,5	+19,5 -19,5	+19,5 -19,5	+23 -23	+23 -23	+27 -27	+27 -27
K6	0 -6	+2 -6	+2 -7	+2 -9	+2 -11	+3 -13	+3 -13	+4 -15	+4 -15	+4 -18	+4 -18
K7	0 -10	+3 -9	+5 -10	+6 -12	+6 -15	+7 -18	+7 -18	+9 -21	+9 -21	+10 -25	+10 -25
K8	0 -14	+5 -13	+16 -16	8 -19	+10 -23	+12 -27	+12 -27	+14 -32	+14 -32	+16 -38	+16 -38
M6	-2 -8	-1 -9	+3 -12	-4 -15	-4 -17	-4 -20	-4 -20	-5 -24	-5 -24	-6 -28	-6 -28
M7	-2 -12	0 -12	0 -15	0 -18	0 -21	0 -25	0 -25	0 -30	0 -30	0 -35	0 -35
M8	-2 -16	+2 -16	+1 -21	+2 -25	+4 -29	+5 -34	+5 -34	+5 -41	+5 -41	+6 -48	+6 -48
N6	-2 -10	-5 -13	-7 -16	-9 -20	-11 -24	-12 -28	-12 -28	-14 -33	-14 -33	-16 -38	-16 -38
N7	-4 -14	-4 -16	-4 -19	-5 -23	-7 -28	-8 -33	-8 -33	-9 -39	-9 -39	-10 -45	-10 -45
N8	-4 -18	-2 -20	-3 -25	-3 -30	-3 -36	-3 -42	-3 -42	-4 -50	-4 -50	-4 -58	-4 -58
P6	-6 -12	-9 -17	-12 -21	-15 -26	-18 -31	-21 -37	-21 -37	-26 -45	-26 -45	-30 -52	-30 -52
P7	-6 -16	-8 -20	-9 -24	-11 -29	-14 -35	-17 -42	-17 -42	-21 -51	-21 -51	-24 -59	-24 -59
P8	-6 -20	-12 -30	-15 -37	-18 -45	-22 -55	-26 -65	-26 -65	-32 -78	-32 -78	-37 -91	-37 -91
R6	-10 -16	-12 -20	-16 -25	-20 -31	-24 -37	-29 -45	-29 -45	-35 -54	-37 -56	-44 -66	-47 -69
R7	-10 -20	-11 -23	-13 -28	-16 -34	-20 -41	-25 -50	-25 -50	-30 -60	-32 -62	-38 -73	-41 -76

TOLERANCIAS PARA DIÁMETROS EXTERIORES TOLERANCES FOR OUTSIDE DIAMETERS

Tolerancias ISO 286-2 para diámetros exteriores / ISO 286-2 tolerances for outside diameters (micron / 0,001 mm)

>	0	3	6	10	18	30	40	50	65	80	100
≤	3	6	10	18	30	40	50	65	80	100	120
a12	-270 -370	-270 -390	-280 -430	-290 -470	-300 -510	-310 -560	-320 -570	-340 -640	-360 -660	-380 -730	-410 -760
d6	-20 -26	-30 -38	-40 -49	-50 -61	-65 -78	-80 -96	-80 -96	-100 -119	-100 -119	-120 -142	-120 -142
e6	-14 -20	-20 -28	-25 -34	-32 -43	-40 -53	-50 -66	-50 -66	-60 -79	-60 -79	-72 -94	-72 -94
e13	-14 -154	-20 -200	-25 -245	-32 -302	-40 -370	-50 -440	-50 -440	-60 -520	-60 -520	-72 -612	-72 -612
f5	-6 -10	-10 -15	-13 -19	-16 -24	-20 -29	-25 -36	-25 -36	-30 -43	-30 -43	-36 -51	-36 -51
f6	-6 -12	-10 -18	13 22	-16 -27	-20 -33	-25 -41	-25 -41	-30 -49	-30 -49	-36 -58	-36 -58
f7	-6 -16	-10 -22	13 28	-16 -34	-20 -41	-25 -50	-25 -50	-30 -60	-30 -60	-36 -71	-36 -71
g5	-2 -6	-4 -9	-5 -11	-6 -14	-7 -16	-9 -20	-9 -20	-10 -23	-10 -23	-12 -27	-12 -27
g6	-2 -8	-4 -12	-5 -14	-6 -17	-7 -20	-9 -25	-9 -25	-10 -29	-10 -29	-12 -34	-12 -34
g7	-2 -12	-4 -16	-5 -20	-6 -24	-7 -28	-9 -34	-9 -34	-10 -40	-10 -40	-12 -47	-12 -47
h3	0 -2	0 -2,5	0 -2,5	0 -3	0 -4	0 -4	0 -4	0 -5	0 -5	0 -6	0 -6
h4	0 -3	0 -4	0 -4	0 -5	0 -6	0 -7	0 -7	0 -8	0 -8	0 -10	0 -10
h5	0 -4	0 -5	0 -6	0 -8	0 -9	0 -11	0 -11	0 -13	0 -13	0 -15	0 -15
h6	0 -6	0 -8	0 -9	0 -11	0 -13	0 -16	0 -16	0 -19	0 -19	0 -22	0 -22
h7	0 -10	0 -12	0 -15	0 -18	0 -21	0 -25	0 -25	0 -30	0 -30	0 -35	0 -35
h8	0 -14	0 -18	0 -22	0 -27	0 -33	0 -39	0 -39	0 -46	0 -46	0 -54	0 -54
h9	0 -25	0 -30	0 -36	0 -43	0 -52	0 -62	0 -62	0 -74	0 -74	0 -87	0 -87
h10	0 -40	0 -48	0 -58	0 -70	0 -84	0 -100	0 -100	0 -120	0 -120	0 -140	0 -140
h11	0 -60	0 -75	0 -90	0 -110	0 -130	0 -160	0 -160	0 -190	0 -190	0 -220	0 -220
h12	0 -100	0 -120	0 -150	0 -180	0 -210	0 -250	0 -250	0 -300	0 -300	0 -350	0 -350

TOLERANCIAS PARA DIAMETROS EXTERIORES
TOLERANCES FOR OUTSIDE DIAMETERS

>	0	3	6	10	18	30	40	50	65	80	100
≤	3	6	10	18	30	40	50	65	80	100	120
j5	+2 -2	+3 -2	+4 -2	+5 -3	+5 -4	+6 -5	+6 -5	+6 -7	+6 -7	+6 -9	+6 -9
j6	+4 -2	+6 -2	+7 -2	+8 -3	+9 -4	+11 -5	+11 -5	+12 -7	+12 -7	+13 -9	+13 -9
j7	+6 -4	+8 -4	+10 -5	+12 -16	+13 -8	+15 -10	+15 -10	+18 -22	+18 -22	+20 -15	+20 -15
js5	+2 -2	+2,5 -5	+3 -3	+4 -4	+4,5 -4,5	+5,5 -5,5	+5,5 -5,5	+6,5 -6,5	+6,5 -6,5	+7,5 -7,5	+7,5 -7,5
js6	+3 -3	+4 -4	+4,5 -4,5	+5,5 -5,5	+6,5 -6,5	+8 -8	+8 -8	+9,5 -9,5	+9,5 -9,5	+11 -11	+11 -11
js7	+5 -5	+6 -6	+7,5 -7,5	+9 -9	+10,5 -10,5	+12,5 -12,5	+12,5 -12,5	+15 -15	+15 -15	+17,5 -17,5	+17,5 -17,5
js9	+12,5 +12,5	+15 +15	+18 +18	+21,5 +21,5	+26 +26	+31 +31	+31 +31	+37 +37	+37 +37	+43,5 +43,5	+43,5 +43,5
js14	+125 +125	+150 +150	+180 +180	+215 +215	+260 +260	+310 +310	+310 +310	+370 +370	+370 +370	+435 +435	+435 +435
js15	+200 +200	+240 +240	+290 +290	+350 +350	+420 +420	+500 +500	+500 +500	+600 +600	+600 +600	+700 +700	+700 +700
k5	+4 0	+6 +1	+7 +1	+9 +1	+11 +2	+13 +2	+13 +2	+15 +2	+15 +2	+18 +3	+18 +3
k6	+6 0	+9 +1	+10 +1	+12 +1	+15 +2	+18 +2	+18 +2	+21 +2	+21 +2	+25 +3	+25 +3
k7	+10 0	+13 +1	+16 +1	+19 +1	+23 +2	+27 +2	+27 +2	+32 +2	+32 +2	+38 +3	+38 +3
m5	+6 +2	+9 +4	+12 +6	+15 +7	+17 +8	+20 +9	+20 +9	+24 +11	+24 +11	+28 +13	+28 +13
m6	+8 +2	+12 +4	+15 +6	+18 +7	+21 +8	+25 +9	+25 +9	+30 +11	+30 +11	+35 +13	+35 +13
m7	+12 +2	+16 +4	+21 +6	+25 +7	+29 +8	+34 +9	+34 +9	+41 +11	+41 +11	+48 +13	+48 +13
n5	+8 +4	+13 +8	+16 +10	+20 +12	+24 +15	+28 +17	+28 +17	+33 +20	+33 +20	+38 +23	+38 +23
n6	+10 +4	+16 +8	+19 +10	+23 +12	+28 +15	+33 +17	+33 +17	+39 +20	+39 +20	+45 +23	+45 +23
n7	+14 +4	+20 +8	+25 +10	+30 +12	+36 +15	+42 +17	+42 +17	+50 +20	+50 +20	+58 +23	+58 +23
p5	+10 +6	+17 +12	+21 +15	+26 +18	+31 +22	+37 +26	+37 +26	+45 +32	+45 +32	+52 +37	+52 +37
p6	+12 +6	+20 +12	+24 +15	+29 +18	+35 +22	+42 +26	+42 +26	+51 +32	+51 +32	+59 +37	+59 +37
r6	+16 +10	+23 +15	+28 +19	+34 +23	+41 +28	+50 +34	+50 +34	+60 +41	+62 +43	+73 +51	+76 +54

CALIDAD DEL ACERO STEEL GRADES

Tabla de comparativa de calidad de Aceros de Cementación / Case Hardening Steel grades comparison table:

Material	ISO 683/1, 10, 11	SAE AISI	BS 970 Part-1	DIN	NF A35 - 551 - 554	JIS A35 - 551 - 554
1.5713	13NiCr6	3115	-	13NiCr6	10NC6	-
1.5752	14NiCr14	3415 - 3310	655H13	14NiCr14	14NC12	-
1.5919	15CrNi6	3115	S107.970-3	15CrNi6	16NC6	-
1.5920	18CrNi8	6264	080M46	18CrNi8	-	-
1.6523	21NiCrMo2	8620	805H20.805M20	21NiCrMo2	20NCD2	SNCM220H
1.6587	17NiCrMo6	4820, 4317	820A16	17NiCrMo6	18NCD2	-
1.7015	15Cr3	5015	523M15.530A32	15Cr3	12C3.15Cr2.18C3	-
1.7034	34Cr4	5135	530A36.530M36	34Cr4	37Cr4.38C4	-
1.7035	41Cr4	5140	530A40.530M40	41Cr4	41Cr4.42C4	-
1.7131	16MnCr5	5115	527M17.590H17	16MnCr5	16MC5.16MnCr5	-
1.7139	16MnCrS5	5115	527M17.590H17	16MnCrS5	16MC5	SMnC420H
1.7147	20MnCr5	5120	-	20MnCr5	20MC5	SMnC420H
1.7149	20MnCrS5	4820, 4826	-	20MnCrS5	-	-
1.7243	18CrMo4	-	708M20	18CrMo4	18CD4	-
1.7321	20MoCr4	8620	805A22	20MoCr4	20MoCr4KD	-
1.7323	20MoCrS4	8620	-	20MoCrS4	-	-
1.7352	25CrMo4	-	-	25CrMo4	-	-
1.7326	25CrMoS4	-	-	25CrMoS4	-	-

Tabla de comparativa de calidad de Aceros Templados / Hardened Steel grades comparison table:

Material	ISO 683/1, 10, 11	SAE AISI	BS 970 Part-1	DIN	NF A35 - 551 - 554	JIS A35 - 551 - 554
1.6511	-	4340, 9840	817M37, 816M40	36CrNiMo4	35NCD5, 40NCD3	-
1.6580	-	4340	823M30	30CrNiMo8	30CND8	SNCM431
1.6582	-	4340, 4337	816M40, 817M40	34CrNiMo6	35NCD3	SNCM447
1.7006	-	5045, 5046	-	46Cr2	42C2, 46Cr2	-
1.7033	34Cr4	5132	530A32, 530M32	34Cr4	32C4, 34Cr4	SCr430
1.7034	34Cr4	5135	530A36, 530M32	37Cr4	38Cr4, 38C4	SCr435
1.7035	41Cr4	5140	530A40.530M40	41Cr4	41Cr4, 42C4	SCr440
1.7218	-	4130	708A25	25CrMo4	25CD4, 25CrMo4	SCM430
1.7220	34CrMo4	4135, 4137	708A37	34CrMo4	35CrMo4, 35CD4	SCM432
1.7225	42CrMo4	4140, 4142	708M40, 311-5/1	42CrMo4	42CD4TS	SCM440
1.7228	-	4150	708A47	50CrMo4	50CrMo4	SCM445

CALIDAD DEL ACERO STEEL GRADES

Tabla de comparativa de calidad de Aceros para herramientas de trabajo en frío / Cold work tool steel grades comparison table:

Material	DIN	AISI	BS	NF / AFNOR	JIS
1.0038	RSt37-2	-	-	-	-
1.0570	St 52-3		50 D	TU E 355 4, TS E 355 4	
1.1191	CK45	1045	080M46	XC42	S45C
1.1221	CK60	1060	080A62	XC60	S58C
1.2080	X210Cr12	D3	BD3	Z200C12, X200Cr12	SKD1
1.2210	115CrV3	L2	-	100C3	-
1.2345	X50CrVMo 5-1	-	-	-	-
1.2510	100MnCrW4	O1	BO 0, BO 1	90MWCV5	-
1.3343	HS6-5-2C	M35, M2	BM2	Z85WDCV06-05-04-02	SKH9, SKH51
1.2379	X155CrVMo 12-1	D2	BD2	Z160CDV12	SKD11
H.2380	X220CrVMo 13-4	-	-	-	-
1.2436	X210CrW12	D6	D6	-	SKD2
1.2601	X165CrMoVa12	-	-	-	SKD11
1.2842	90MnCrV8	O2	BO2	90MV8	-
1.3505	100Cr6	52100	534A99	100C6	SUJ2
1.4016	X8Cr17	430	430S15	Z8C17	SUS430

Tabla de comparativa de calidad de Aceros para herramientas de trabajo en caliente (HWS) / Hot work tool steel (HWS) grades comparison table:

Material	DIN	AISI	BS	NF / AFNOR	JIS
1.2312	-	P20+S	-	-	-
1.2343	X38CrMoV 5-1	H11	BH11	Z38CDV5	SKD6
1.2344	X40CrMoV 5.1	H13	BH13	Z40CDV5	SKD61
1.2365	X32CrMoV 3.3	H10	BH10	32CDV28	SKD7
H.2367	X38CrMoV 5.3	H11	BH11	-	SKD61
1.2581	X30WCRV 9.3	H21	BH21	Z30WCV9	SKD5
1.2714	X 165CrMoVa 12	6F3, L6	BS224	55NCDV7	SKT4

ALEACIONES DEL BRONCE BRONZE ALLOYS

Tabla de comparativa de aleaciones del bronce / Bronze alloys comparison table:

Material	DIN	EN	NF AFNOR	BS	ISO	JIS	SAE AISI
2.0220	CuZn5	CW500L	CuZn5	CZ125	CuZn5	C2100	C2100 . B134-1
2.0230	CuZn10	CW501L	CuZn10	CZ101	CuZn10	C2200	C22000
2.0240	CuZn15	CW502L	CuZn15	CZ102	CuZn15	C2300	C23000 . B134 - 6 . B135-1
2.0250	CuZn20	CW503L	CuZn20	CZ102	CuZn20	C2400	C24000
2.0265	CuZn30	CW505L	CuZn30	CZ102	CuZn30	C2600	C23000 . B134 - 6 . B135-2
2.0321	CuZn37	CW508L	CuZn37	CZ108	-	C2700	C27200 . MS63
2.0360	CuZn40	CW509L	CuZn40	CZ109	CuZn40	C2800	C28000
2.0598	CuZn25Al5	CC762	-	HTB3	CuZn25	-	C86300 . SAE 430B
2.0596	CuZn34Al2	-	U-Z 36 N3	HTB1	-	-	C86200 . SAE 430A
2.0592	CuZn35Al1	-	U-Z 36 N3	HTB1	CuZn35	-	C86500 . SAE 43
2.0510	CuZn37Al1	CW716R	-	-	-	-	-
2.0550	CuZn40Al2	CW713R	-	C2135	CuZn37	-	C76420 . So - MS Al2
2.0561	CuZn40Al1	CW718R	-	-	-	-	-
2.0401	CuZn39Pb3	CW614N	-	CZ121 Pb3	-	-	MS58
2.0241	CuZn39Pb2	CW617N	-	CZ123	-	-	So - MS58 Pb2
2.0460	CuZn20Al2	CW720R	-	-	-	-	-
2.0872	CuNi10Fe1Mn	-	-	-	-	-	-
2.0882	CuNi30Mn1Fe	CW354H	-	-	-	-	-
2.0936	CuAl10Fe3Mn2	-	-	-	-	-	-
2.0975	CuAl8Mn	-	-	-	-	-	-
2.0936	CuAl10Fe	CW306G	-	-	-	-	C45200 . B125 . B124
2.0975.04	CuAl10Ni	-	U-A-10N	-	-	-	C95500
2.0978	CuAl11Fe6Ni6	CW307G	-	-	-	-	-

DUREZAS DE ACERO STEEL HARDNESS

Tabla de conversión de durezas de acero / Steel hardness conversion table:

Fuerza de Tensión / Tensile Strength N / mm ²	Vickers HV	Brinell HB	Rockwell HRC
835	260	247	24
850	265	252	24.8
865	270	257	25.6
880	275	261	26.4
900	280	266	27.1
915	285	271	27.8
930	290	276	28.5
950	295	280	29.2
965	300	285	29.8
1030	310	295	31
1060	320	304	32.2
1095	330	314	33.3
1125	340	323	33.4
1155	350	333	33.5
1190	360	342	36.6
1220	370	352	37.7
1255	380	361	38.8
1290	390	371	39.8
1320	400	380	40.8
1350	410	390	41.8
1385	420	399	42.7
1420	430	409	43.6
1455	440	418	44.5
1485	450	428	45.3
1520	460	437	46.1
1555	470	447	46.9
1595	480	-456	47.7
1630	490	-466	48.4
1665	500	-476	49.1
1700	510	-485	49.8
1740	520	-495	50.5
1775	530	-504	51.1
1810	540	-513	51.7
1845	550	-523	52.3
1880	560	-532	53
1920	570	-542	53.6
1955	580	-551	54.1
1995	590	-561	54.7
2030	600	-570	55.2
2070	610	-580	55.7
2105	620	-589	56.3
2145	630	-599	56.8
2180	640	-608	57.3
-	650	-618	57.8
-	660	-	58.3
-	670	-	58.8
-	680	-	59.2
-	690	-	59.7
-	700	-	60.1
-	720	-	61
-	740	-	61.8
-	760	-	62.5
-	780	-	63.3
-	800	-	64
-	820	-	64.7
-	840	-	65.3

