

PINZAS DE SUJECCIÓN ER PARA PORTAHERRAMIENTAS

New!

ER Collets for Tool-Holders

Pinces ER pour les porte-outils

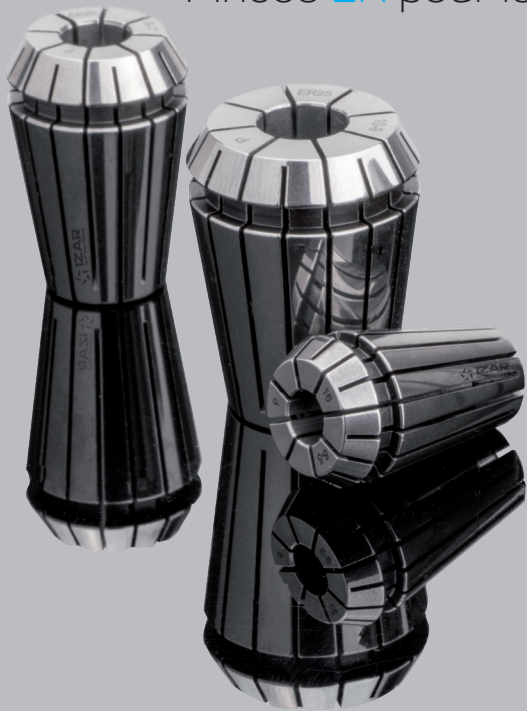

Ref. 8390

ULTRAPRECISIÓN

P
↗ 0,005

Ref. 8391

ALTA PRECISIÓN

A
↗ 0,01

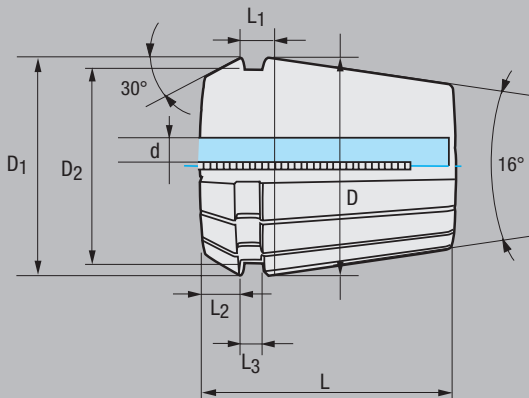

TIPO Type Type	d	D	D1	D2	L	L1	L2	L3	Compresión elástica Elastic compression Compression élastique
ER11	1,0-7,0	11,50	11,50	9,50	18,00	3,80	2,50	2,00	0,50
ER16	1,0-2,5	16,00	17,00	13,80	27,50	6,26	4,00	2,70	0,50
	>2,5-10,0	16,00	17,00	13,80	27,50	6,26	4,00	2,70	1,00
ER20	2,0-2,5	20,00	21,00	17,40	31,50	6,36	4,80	2,80	0,50
	>2,5-13,0	20,00	21,00	17,40	31,50	6,36	4,80	2,80	1,00
ER25	2,0-2,5	25,00	26,00	22,00	34,00	6,66	5,00	3,10	0,50
	>2,5-16,0	25,00	26,00	22,00	34,00	6,66	5,00	3,10	1,00
ER32	>3,0-20,0	32,00	33,00	29,20	40,00	7,16	5,50	3,60	1,00
ER40	3,0-26,0	40,00	41,00	36,20	46,00	7,66	7,00	4,10	1,00

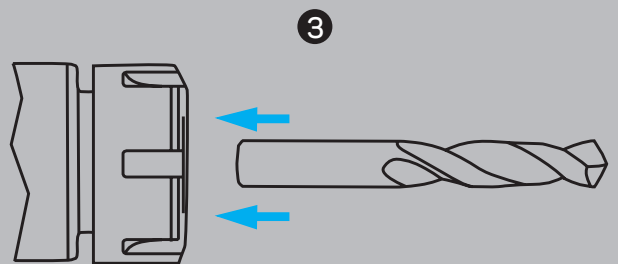
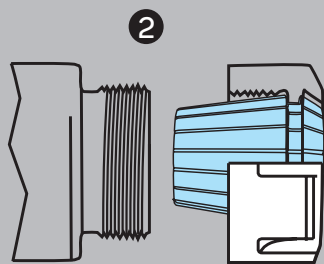
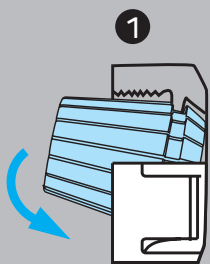

COLOCACIÓN DE LA HERRAMIENTA

- Colocar la pinza ER en la tuerca ER
- Bloquear la pinza ER y la tuerca ER en el porta
- Insertar la herramienta en la pinza ER y luego apretar la tuerca

TOOL INSTALATION

- Put the ER collet into the ER nut
- Lock the ER collet and the ER nut into the holder
- Insert the tool into the ER collet and then tighten the nut

MISE EN PLACE DE L'OUTIL

- Mettez la pince ER dans l'écrou ER
- Verrouillez la pince ER et l'écrou ER dans le porte-outil
- Insérez l'outil dans la pince ER puis serrez l'écrou

Ref. **8390**

PINZAS DE SUJECIÓN ER DE ULTRAPRECISIÓN

Ultra Precision ER Collets

Pinces de fixation ER ultraprécision

New!



Clase
Class Classe
P

Tol.
0,005
mm

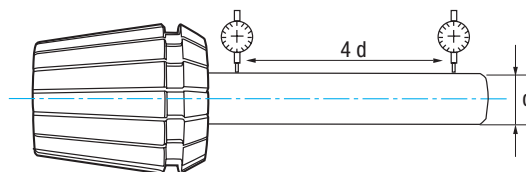

TIPO Type Type	RANGO Range Intervalle	N° Art.	€
----------------------	------------------------------	------------	---

ER11

ER11-1	1,0-0,5	22134	56,33
ER11-1.5	1,5-1,0	22135	56,33
ER11-2	2,0-1,5	22136	56,33
ER11-2.5	2,5-2,0	22137	56,33
ER11-3	3,0-2,5	22138	56,33
ER11-3.5	3,5-3,0	22139	56,33
ER11-4	4,0-3,5	22141	56,33
ER11-4.5	4,5-4,0	22147	56,33
ER11-5	5,0-4,5	22148	56,33
ER11-5.5	5,5-5,0	22149	56,33
ER11-6	6,0-5,5	22152	56,33
ER11-6.5	6,5-6,0	22153	56,33
ER11-7	7,0-6,5	22157	56,33

ER16

ER16-1	1,0-0,5	22158	51,59
ER16-2	2,0-1,5	22159	51,59
ER16-3	3,0-2,0	22160	51,59
ER16-4	4,0-3,0	22161	51,59
ER16-5	5,0-4,0	22163	51,59
ER16-6	6,0-5,0	22164	51,59
ER16-7	7,0-6,0	22165	51,59
ER16-8	8,0-7,0	22166	51,59
ER16-9	9,0-8,0	22167	51,59
ER16-10	10,0-9,0	22168	51,59

ER20

ER20-2	2,0-1,5	22169	51,59
ER20-3	3,0-2,0	22170	51,59
ER20-4	4,0-3,0	22171	51,59
ER20-5	5,0-4,0	22172	51,59
ER20-6	6,0-5,0	22173	51,59
ER20-7	7,0-6,0	22174	51,59
ER20-8	8,0-7,0	22175	51,59
ER20-9	9,0-8,0	22176	51,59
ER20-10	10,0-9,0	22177	51,59
ER20-11	11,0-10,0	22178	51,59
ER20-12	12,0-11,0	22179	51,59
ER20-13	13,0-12,0	22180	51,59

TIPO Type Type	RANGO Range Intervalle	N° Art.	€
----------------------	------------------------------	------------	---

ER25

ER25-2	2,0-1,5	22185	53,96
ER25-3	3,0-2,0	22186	53,96
ER25-4	4,0-3,0	22187	53,96
ER25-5	5,0-4,0	22188	53,96
ER25-6	6,0-5,0	22189	53,96
ER25-7	7,0-6,0	22190	53,96
ER25-8	8,0-7,0	22195	53,96
ER25-9	9,0-8,0	22196	53,96
ER25-10	10,0-9,0	22197	53,96
ER25-11	11,0-10,0	22198	53,96
ER25-12	12,0-11,0	22200	53,96
ER25-13	13,0-12,0	22201	53,96
ER25-14	14,0-13,0	22202	53,96
ER25-15	15,0-14,0	22203	53,96
ER25-16	16,0-15,0	22204	53,96

ER32

ER32-3	3,0-2,0	22206	56,33
ER32-4	4,0-3,0	22208	56,33
ER32-5	5,0-4,0	22209	56,33
ER32-6	6,0-5,0	22210	56,33
ER32-7	7,0-6,0	22219	56,33
ER32-8	8,0-7,0	22225	56,33
ER32-9	9,0-8,0	22230	56,33
ER32-10	10,0-9,0	22231	56,33
ER32-11	11,0-10,0	22253	56,33
ER32-12	12,0-11,0	22259	56,33
ER32-13	13,0-12,0	22276	56,33
ER32-14	14,0-13,0	22277	56,33
ER32-15	15,0-14,0	22279	56,33
ER32-16	16,0-15,0	22282	56,33
ER32-17	17,0-16,0	22285	56,33
ER32-18	18,0-17,0	22286	56,33
ER32-19	19,0-18,0	22287	56,33
ER32-20	20,0-19,0	22290	56,33

TIPO Type Type	RANGO Range Intervalle	N° Art.	€
----------------------	------------------------------	------------	---

ER40

ER40-3	3,0-2,0	22291	65,04
ER40-4	4,0-3,0	22292	65,04
ER40-5	5,0-4,0	22295	65,04
ER40-6	6,0-5,0	22305	65,04
ER40-7	7,0-6,0	22310	65,04
ER40-8	8,0-7,0	22313	65,04
ER40-9	9,0-8,0	22314	65,04
ER40-10	10,0-9,0	22316	65,04
ER40-11	11,0-10,0	22318	65,04
ER40-12	12,0-11,0	22319	65,04
ER40-13	13,0-12,0	22333	65,04
ER40-14	14,0-13,0	22335	65,04
ER40-15	15,0-14,0	22338	65,04
ER40-16	16,0-15,0	22339	65,04
ER40-17	17,0-16,0	22345	65,04
ER40-18	18,0-17,0	22355	65,04
ER40-19	19,0-18,0	22356	65,04
ER40-20	20,0-19,0	22357	65,04
ER40-21	21,0-20,0	22358	65,04
ER40-22	22,0-21,0	22359	65,04
ER40-23	23,0-22,0	22360	65,04
ER40-24	24,0-23,0	22361	65,04
ER40-25	25,0-24,0	22362	65,04
ER40-26	26,0-25,0	23033	65,04



Ref. **8391**

PINZAS DE SUJECCIÓN ER DE ALTA PRECISIÓN

High Precision ER Collets

Pinces de fixation ER haute précision

New!



Clase Class Classe A	Tol. 0,01 mm
-----------------------------------	---------------------------

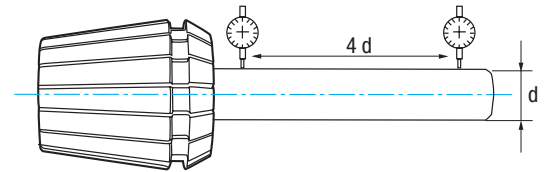

TIPO Type Type	RANGO Range Intervalle	N° Art.	€
----------------------	------------------------------	------------	---

ER11			
ER11-1	1,0-0,5	22363	36,30
ER11-1.5	1,5-1,0	22364	36,30
ER11-2	2,0-1,5	22366	36,30
ER11-2.5	2,5-2,0	22367	36,30
ER11-3	3,0-2,5	22368	36,30
ER11-3.5	3,5-3,0	22369	36,30
ER11-4	4,0-3,5	22375	36,30
ER11-4.5	4,5-4,0	22376	36,30
ER11-5	5,0-4,5	22377	36,30
ER11-5.5	5,5-5,0	22378	36,30
ER11-6	6,0-5,5	22379	36,30
ER11-6.5	6,5-6,0	22380	36,30
ER11-7	7,0-6,5	22381	36,30

ER16			
ER16-1	1,0-0,5	22382	33,40
ER16-2	2,0-1,5	22383	33,40
ER16-3	3,0-2,0	22384	33,40
ER16-4	4,0-3,0	22385	33,40
ER16-5	5,0-4,0	22386	33,40
ER16-6	6,0-5,0	22387	33,40
ER16-7	7,0-6,0	22388	33,40
ER16-8	8,0-7,0	22390	33,40
ER16-9	9,0-8,0	22393	33,40
ER16-10	10,0-9,0	22394	33,40

ER20			
ER20-2	2,0-1,5	22396	33,40
ER20-3	3,0-2,0	22397	33,40
ER20-4	4,0-3,0	22398	33,40
ER20-5	5,0-4,0	22399	33,40
ER20-6	6,0-5,0	22401	33,40
ER20-7	7,0-6,0	22402	33,40
ER20-8	8,0-7,0	22403	33,40
ER20-9	9,0-8,0	22404	33,40
ER20-10	10,0-9,0	22409	33,40
ER20-11	11,0-10,0	22411	33,40
ER20-12	12,0-11,0	22412	33,40
ER20-13	13,0-12,0	22414	33,40

TIPO Type Type	RANGO Range Intervalle	N° Art.	€
----------------------	------------------------------	------------	---

ER25			
ER25-2	2,0-1,5	22415	35,10
ER25-3	3,0-2,0	22416	35,10
ER25-4	4,0-3,0	22422	35,10
ER25-5	5,0-4,0	22424	35,10
ER25-6	6,0-5,0	22426	35,10
ER25-7	7,0-6,0	22427	35,10
ER25-8	8,0-7,0	22428	35,10
ER25-9	9,0-8,0	22433	35,10
ER25-10	10,0-9,0	22434	35,10
ER25-11	11,0-10,0	22435	35,10
ER25-12	12,0-11,0	22437	35,10
ER25-13	13,0-12,0	22439	35,10
ER25-14	14,0-13,0	22440	35,10
ER25-15	15,0-14,0	22442	35,10
ER25-16	16,0-15,0	22443	35,10

ER32			
ER32-3	3,0-2,0	22444	36,30
ER32-4	4,0-3,0	22445	36,30
ER32-5	5,0-4,0	22446	36,30
ER32-6	6,0-5,0	22447	36,30
ER32-7	7,0-6,0	22452	36,30
ER32-8	8,0-7,0	22453	36,30
ER32-9	9,0-8,0	22454	36,30
ER32-10	10,0-9,0	22455	36,30
ER32-11	11,0-10,0	22458	36,30
ER32-12	12,0-11,0	22461	36,30
ER32-13	13,0-12,0	22462	36,30
ER32-14	14,0-13,0	22467	36,30
ER32-15	15,0-14,0	22468	36,30
ER32-16	16,0-15,0	22469	36,30
ER32-17	17,0-16,0	22471	36,30
ER32-18	18,0-17,0	22476	36,30
ER32-19	19,0-18,0	22478	36,30
ER32-20	20,0-19,0	22479	36,30

TIPO Type Type	RANGO Range Intervalle	N° Art.	€
----------------------	------------------------------	------------	---

ER40			
ER40-3	3,0-2,0	22481	41,90
ER40-4	4,0-3,0	22482	41,90
ER40-5	5,0-4,0	22483	41,90
ER40-6	6,0-5,0	22484	41,90
ER40-7	7,0-6,0	22487	41,90
ER40-8	8,0-7,0	22488	41,90
ER40-9	9,0-8,0	22491	41,90
ER40-10	10,0-9,0	22498	41,90
ER40-11	11,0-10,0	22501	41,90
ER40-12	12,0-11,0	22504	41,90
ER40-13	13,0-12,0	22505	41,90
ER40-14	14,0-13,0	22529	41,90
ER40-15	15,0-14,0	22535	41,90
ER40-16	16,0-15,0	22538	41,90
ER40-17	17,0-16,0	22541	41,90
ER40-18	18,0-17,0	22544	41,90
ER40-19	19,0-18,0	22561	41,90
ER40-20	20,0-19,0	22566	41,90
ER40-21	21,0-20,0	22567	41,90
ER40-22	22,0-21,0	22569	41,90
ER40-23	23,0-22,0	22572	41,90
ER40-24	24,0-23,0	22573	41,90
ER40-25	25,0-24,0	22575	41,90
ER40-26	26,0-25,0	22584	41,90



Set	Pcs	Cont.	N° Art.	Set Price!
ER11	13	1 - 1,5 - 2 - 2,5 - 3 - 3,5 - 4 - 4,5 - 5 - 5,5 - 6 - 6,5 - 7	24563	448,31
ER16	10	1 - 2 - 3 - 4 - 5 - 6 - 7 - 8 - 9 - 10	24571	317,30
ER20	12	2 - 3 - 4 - 5 - 6 - 7 - 8 - 9 - 10 - 11 - 12 - 13	24575	380,76
ER25	15	2 - 3 - 4 - 5 - 6 - 7 - 8 - 9 - 10 - 11 - 12 - 13 - 14 - 15 - 16	24579	500,18

Set	Pcs	Cont.	N° Art.	Set Price!
ER32	18	3 - 4 - 5 - 6 - 7 - 8 - 9 - 10 - 11 - 12 - 13 - 14 - 15 - 16 - 17 - 18 - 19 - 20	24584	620,73
ER40	24	3 - 4 - 5 - 6 - 7 - 8 - 9 - 10 - 11 - 12 - 13 - 14 - 15 - 16 - 17 - 18 - 19 - 20 - 21 - 22 - 23 - 24 - 25 - 26	24590	955,32

Ref. **8395**

PINZAS DE SUJECCIÓN DE GRAN APRIETE DE ALTA PRECISIÓN

High Precision Strong Collets

Pinces de fixation de grand serrage haute précision

New!



Clase
Class Classe
A

Tol.
0,01
mm

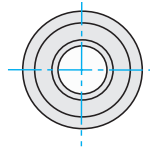
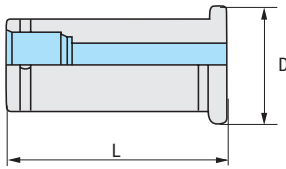
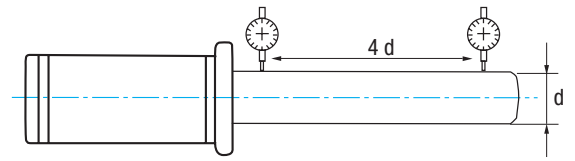

TIPO Type Type	MEDIDA Size Mesure	D	L
C20	6, 8, 10, 12, 16	26,00	55,00
C25	6, 8, 10, 12, 16, 20	30,00	63,00
C32	4, 5, 6, 8, 10, 12, 14, 16, 18, 20, 25	38,00	70,00
C42	6, 8, 10, 12, 16, 20, 25, 32	48,00	75,00

TIPO Type Type	Nº Art.	€
C20		
C20-6	25195	49,80
C20-8	25202	49,80
C20-10	25205	49,80
C20-12	25209	49,80
C20-16	25210	49,80

TIPO Type Type	Nº Art.	€
C25		
C25-6	25212	49,80
C25-8	25213	49,80
C25-10	25214	49,80
C25-12	25215	49,80
C25-16	25216	49,80
C25-20	25223	49,80

TIPO Type Type	Nº Art.	€
C32		
C32-4	25225	49,80
C32-5	25232	49,80
C32-6	25236	49,80
C32-8	25238	49,80
C32-10	25239	49,80
C32-12	25240	49,80
C32-14	25241	49,80
C32-16	25242	49,80
C32-18	25243	49,80
C32-20	25244	49,80
C32-25	25245	49,80

TIPO Type Type	Nº Art.	€
C42		
C42-6	25246	59,76
C42-8	25247	59,76
C42-10	25248	59,76
C42-12	25249	59,76
C42-16	25250	59,76
C42-20	25251	59,76
C42-25	25252	59,76
C42-32	25254	59,76



Set	Pcs	Cont.	Nº Art.	Set Price!
C20	5	6 - 8 - 10 - 12 - 16	25302	236,55
C32	11	4 - 5 - 6 - 8 - 10 - 12 - 14 - 16 - 18 - 20 - 25	25300	520,41

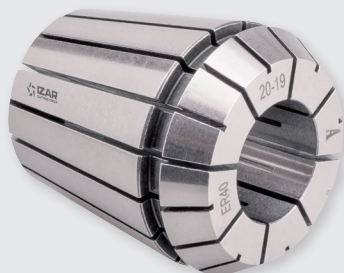

Ref. 8391



Ref. 8395



COMERCIAL NACIONAL

E-mail comercial@izartool.com

Pedidos y Atención a Clientes

Tel. 94 630 02 41

Fax 94 630 02 36

EXPORT SALES

E-mail export@izartool.com

Orders & Customer Assistance

Tel. +34 94 630 02 46

Fax +34 94 630 02 37

VENTES FRANCE

Courriel france@izartool.com

Tel. +34 94 630 02 45

izartool.com

