

SERIES
TWIN CUT
15-20-30



The OneCut series are complete groups of machines for cutting metal and deformation from coils.

Uncoil, straighten and cut the shape (slitting and cut-to-length) simultaneously with absolute efficiency, avoiding manipulation, unnecessary costs and wastage of material. These are lines of work that do not require large areas and are highly productive.

Fully automated and programmable, with some adjustments necessarily manuals have a total reliability.



Slitting cut detail.

SOMETHINGS APLICCCATIONS

- Metal closings
- Metalic doors and blinds
- Metalic prefabricators
- Tows, caravans
- Ducs, air channel
- Industrial refrigerators
- Cutting centers
- Lifts
- General sheets procesings

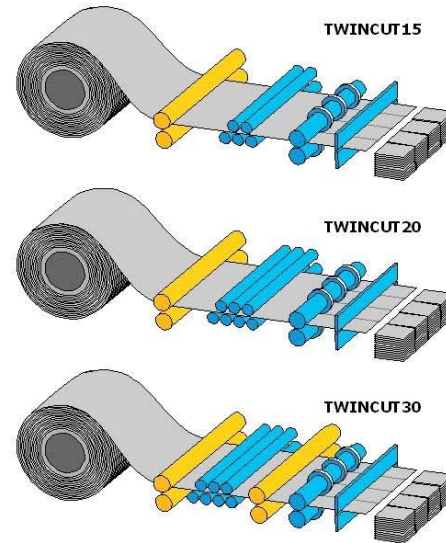

**INSTALATION
COMPOSITION**

- **Coil car**
For various tonnages
Machine built in high-strength steel soldier on design, with elevation by hydraulic cylinders and displacement motorized.
- **Uncoiler**
Built with welded steel frame on dimensioning of high strength, spindle cantilever, hydraulic expansion of the 4 tiles autocentrantes motorized rotation and controlled by variable speed, working loop.
- **Controls**
Controls all the elements that make up the line. At the top are all buttons, selectors, the digital display and keyboard embedded electronic program

- **Strip-end Input Unit**
Table threading pneumatic or hydraulic

• **Straight and Cutting Unit**

Straightened
Steel frame with 2 rollers soldier shot and 5,7 or 9 (depending on model) straightening rolls, with height adjustment and manual steering wheel through digital visualization of the elevation. Straighten engine BRUSHLESS

Slitting unit
Situating on the same frame that the straightening, contains 3 to 5 games fast adjustment blade with double-edged separator nitrile. Regulation of the penetration of the blades through the steering wheel and digital display.

Shearing unit
Guillotine shear mechanical clutch brake TYRE of direct attack. Suitable for cutting stainless steel with double gift cutting edge. Frame smooth, without gooseneck, comprehensive regulation of space between blades.
Pisador covered with PVC to protect the plate at the time of the court, centralised lubrication for guides and vital parts of the machine

Different cutting possibilities
Cut ; Cut and Marked ; Cut and Punching

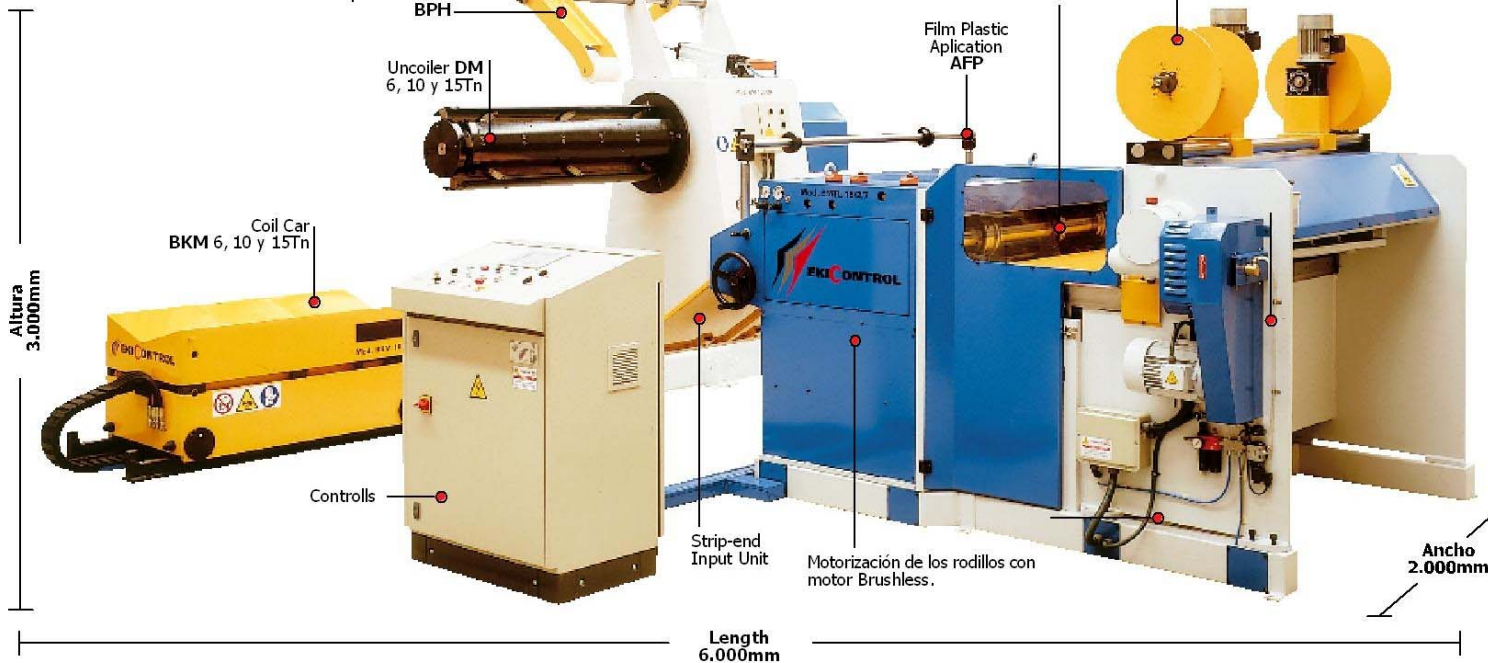

We make special lines on demand, according to their needs with economic solutions and cost-effective, increasing productivity by reducing costs and avoiding waste. We are at your disposal to get involved in their project and make it happen