

*Solutions for Metalworking*  
[www.tcpunzones.com](http://www.tcpunzones.com)



# Thick Turret system

**TC PUNZONES Y MATRICES**  
[www.tcpunzones.com](http://www.tcpunzones.com)  
Tlf. +34 934 228 023  
[info@tcpunzones.com](mailto:info@tcpunzones.com)

## Thick Turret System

Tipo A <i>Type A</i> . . . . .	pág. 3
Tipo A Porta Punzón Intercambiable <i>Type A Punch Holder Insert</i> . . . . .	pág. 4
Tipo B <i>Type B</i> . . . . .	pág. 5
Tipo B Porta Punzón Intercambiable <i>Type B Punch Holder Insert</i> . . . . .	pág. 6
Tipo C <i>Type C</i> . . . . .	pág. 7
Tipo D <i>Type D</i> . . . . .	pág. 8
Tipo E <i>Type E</i> . . . . .	pág. 9
Tipo C y D Porta Cuchillas y Cuchillas <i>Type C &amp; D Blade Holder &amp; Blades</i> . . . . .	pág. 10
Tipo E Porta Cuchillas y Cuchillas <i>Type E Blade Holder &amp; Blades</i> . . . . .	pág. 11
Porta Punzones Múltiple <i>Cluster Punch Holder</i> . . . . .	pág. 12
Multi Tools <i>Multi Tools</i> . . . . .	pág. 13
Avellanadores <i>Countersinks</i> . . . . .	pág. 14
Embutidores <i>Form Tools</i> . . . . .	pág. 15
Reductoras <i>Adapters Tool</i> . . . . .	pág. 17
Chavetas Máquinas Amada® <i>Amada® Machine Keys</i> . . . . .	pág. 18

## Información Técnica / Tecnic information

Figuras Especiales <i>Special Shapes</i> . . . . .	pág. 19
Embuticiones <i>Forming Tools</i> . . . . .	pág. 21
Múltiples <i>Clusters</i> . . . . .	pág. 23
Tolerancia y Tonelaje <i>Clearance &amp; Tonnage</i> . . . . .	pág. 25
Tipo de Rectificado <i>Grinding type</i> . . . . .	pág. 26
Tratamientos Superficiales <i>Coating Solutions</i> . . . . .	pág. 27
Mantenimiento <i>Maintenance</i> . . . . .	pág. 28
Servicio <b>TC</b> <i>TC Service</i> . . . . .	pág. 29





Sistema largo / Thick turret

**\*Tipo De Sistema  
Por Posición Chaveta**  
\*System Type For  
Key Position

59.5mm  
Sistema HP  
HP system

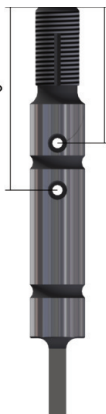

39mm  
Sistema  
WLS  
WLS system



Sistema WT / WT system



Sistema UT / UT system

- Figura máxima inscrita en Ø12,7mm
  - Maximum shape inscribed in Ø12,7mm
  - Suplementos de matriz de espesor
  - Die supplement Shims
- 0,3 - 0,5 mm**



**Sistema largo / Thick turret**



*Porta Punzón  
Sistema Largo  
Punch Holder  
Thick Turret System*

*Punzón  
Intercambiable Ø6  
Insert Punch Ø6*

*Casquillo Porta Punzón  
Punch Holder Cap*

**Sistema WT / WT system**



*Porta Punzón  
Sistema WT  
Punch Holder  
WT System*

*Punzón  
Intercambiable Ø6  
Insert Punch Ø6*

*Casquillo Porta Punzón  
Punch Holder Cap*

**Sistema UT / UT system**



*Porta Punzón  
Sistema UT  
Punch Holder  
UT System*

*Punzón  
Intercambiable Ø6  
Insert Punch Ø6*

*Casquillo Porta Punzón  
Punch Holder Cap*



Sistema largo / Thick turret



Sistema Estándar  
Standard System



Sistema BR  
Heavy duty BR System

Sistema WT / WT system



64mm  
Sistema  
HP  
HP system

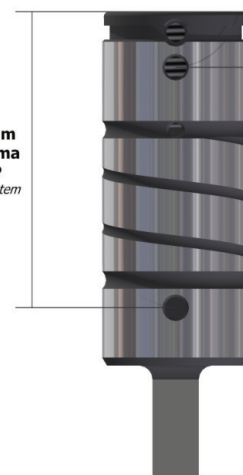

12mm  
Sistema  
WLS  
WLS system

Sistema UT / UT system

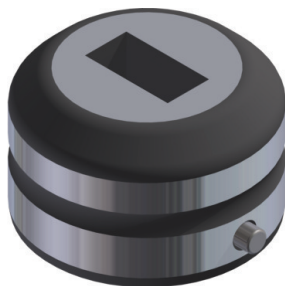
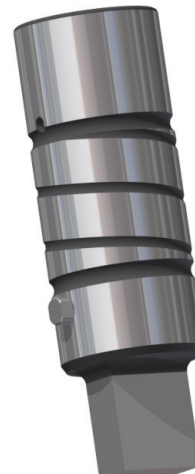

- Figura máxima inscrita en Ø31,7mm
- Maximum shape incirbed in Ø31,7mm
- Suplementos de matriz de espesor
- Die supplement Shims
- 0,3 - 0,5 mm

**Sistema largo / Thick turret**



Vástago largo  
Thick Turret Stem

Punzón  
Intercambiable Ø10  
Insert Punch Ø10

Porta Punzón  
Sistema Largo  
Punch Holder  
Thick Turret System

**Sistema WT / WT system**



Punzón  
Intercambiable Ø10  
Insert Punch Ø10

Porta Punzón  
Sistema WT  
Punch Holder  
WT System

**Sistema UT / UT system**



Punzón  
Intercambiable Ø10  
Insert Punch Ø10

Porta Punzón  
Sistema UT  
Punch Holder  
UT System

- Figura máxima inscrita en Ø10mm  
- Maximum shape incised in Ø10mm

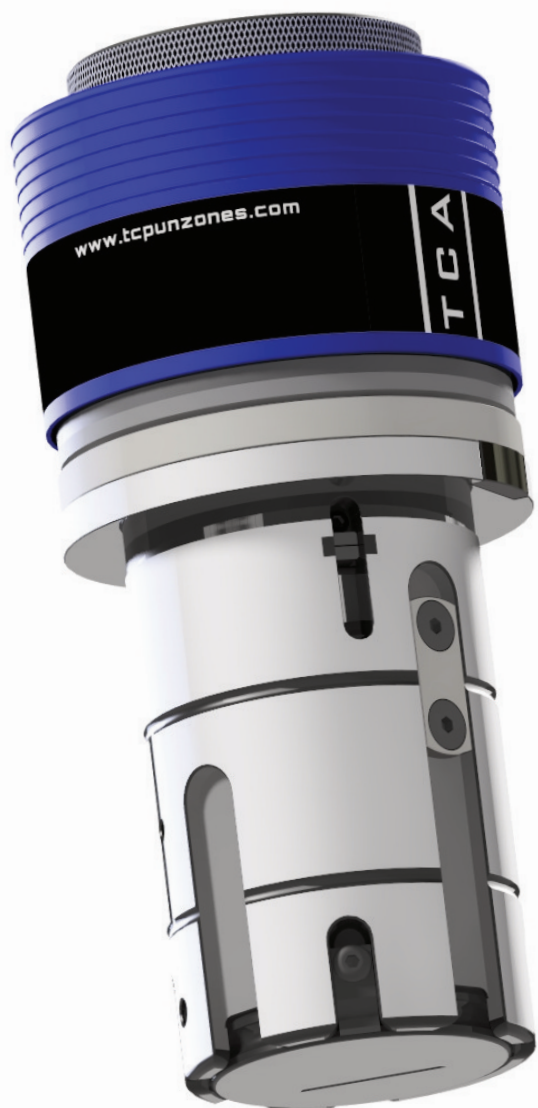

Sistema largo / Thick turret

Sistema UT / UT system

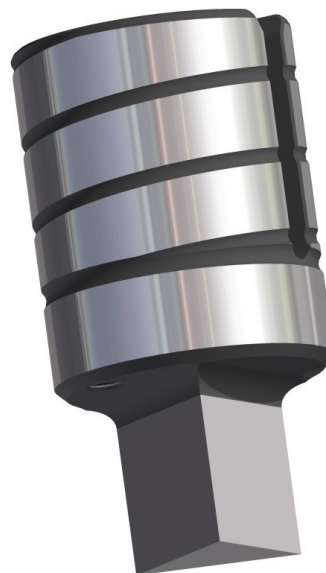

Sistema WT / WT system

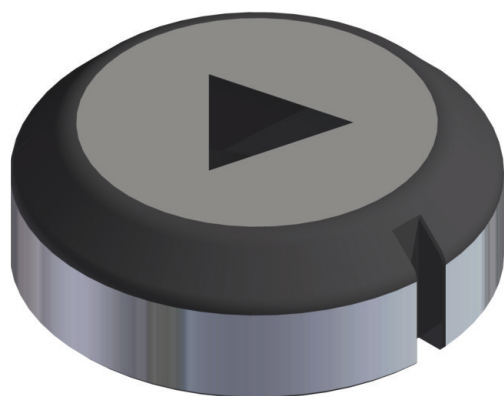
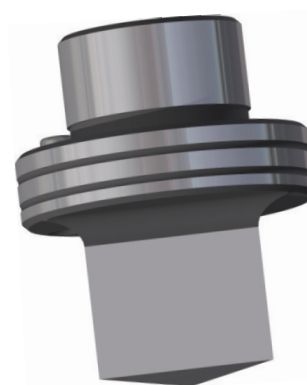

- **Figura máxima inscrita en  $\text{Ø}50,8\text{mm}$**
- *Maximum shape inscribed in  $\text{Ø}50,8\text{mm}$*
- **Suplementos de matriz de espesor**
- *Die supplement Shims*
- 0,3 - 0,5 mm**





Sistema largo / Thick turret

Sistema UT / UT system

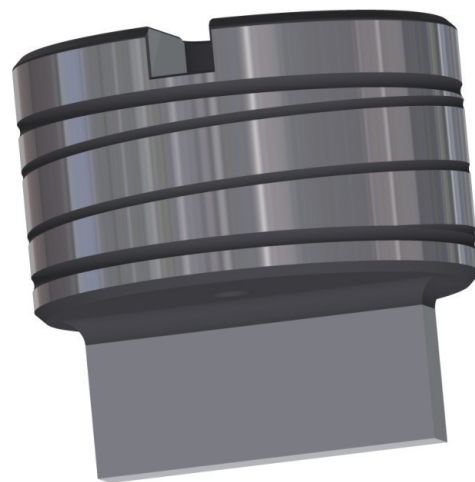

Sistema WT / WT system

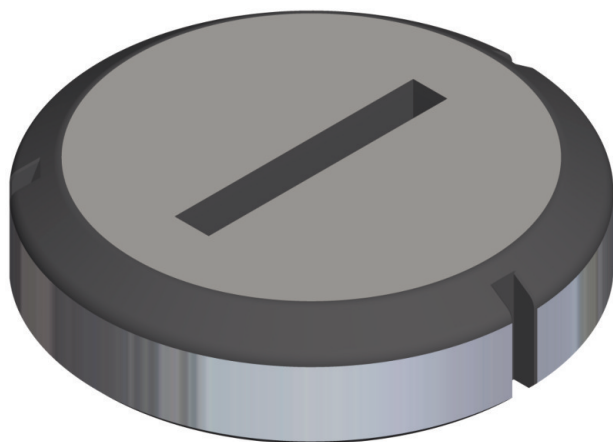
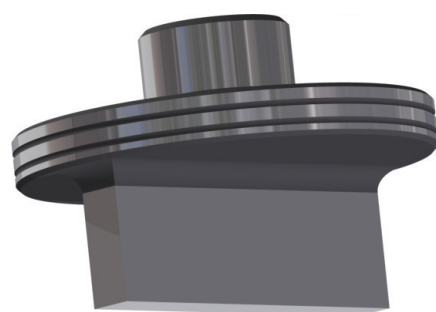

- Figura máxima inscrita en  $\text{Ø}88,9\text{mm}$

- Maximum shape inscribed in  $\text{Ø}88,9\text{mm}$

- Suplementos de matriz de espesor

- Die supplement Ring

0,3 - 0,5 mm



Sistema largo / Thick turret

Sistema UT / UT system

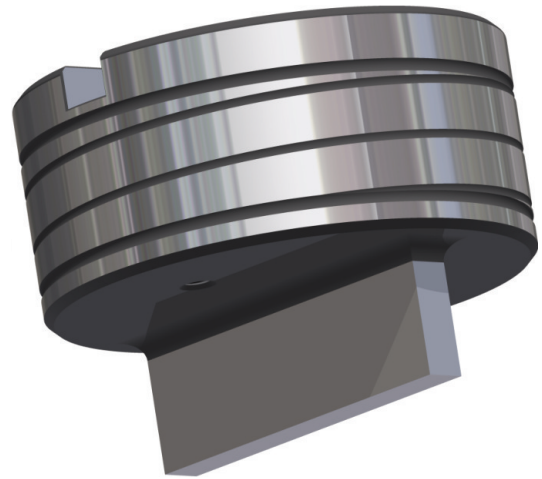

Sistema WT / WT system

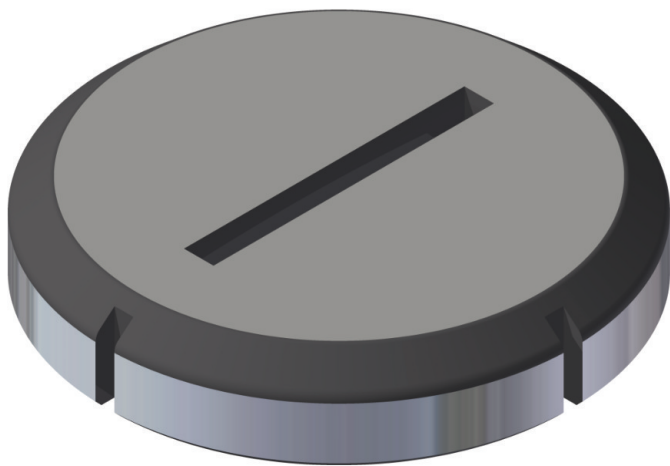
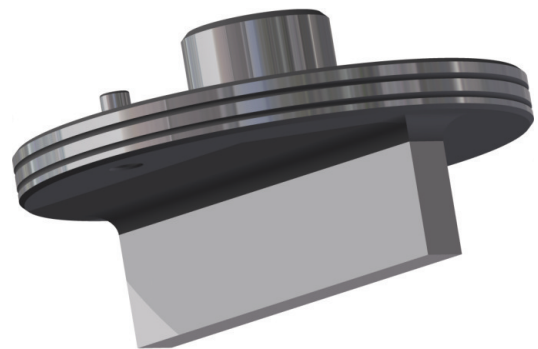

- Figura máxima inscrita en  $\text{Ø}114,3\text{mm}$
- Maximum shape inscribed in  $\text{Ø}114,3\text{mm}$
- Suplementos de matriz de espesor
- Die supplement Shims
- 0,3 - 0,5 mm

**Tipo C / Type C**

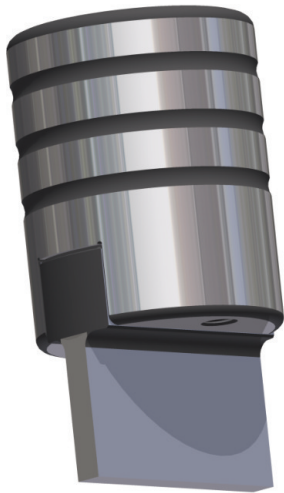

*Cuchilla Estándar / Standard Blade*

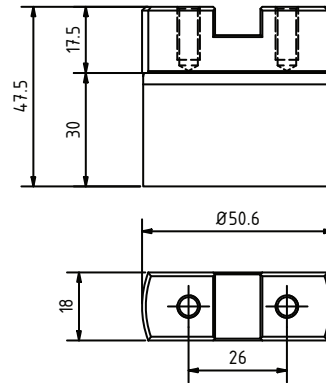

**Tipo D / Type D**

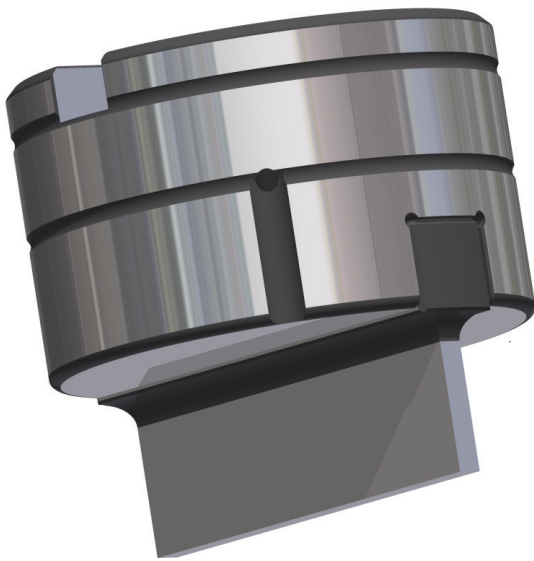

*Cuchilla Estándar / Standard Blade*

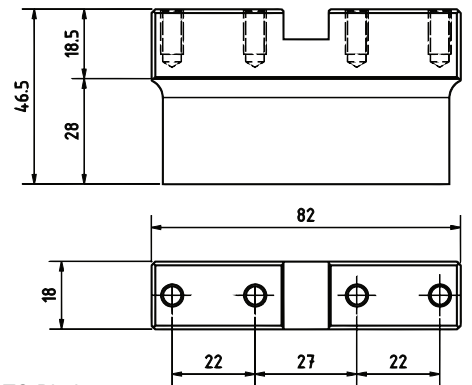

*Cuchilla TC / TC Blade*

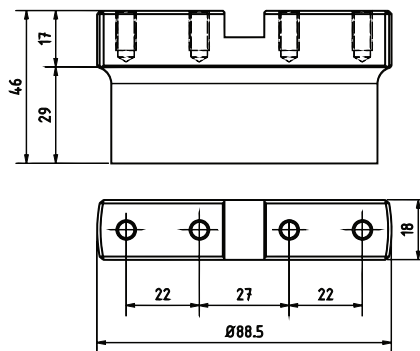

*Cuchilla UT / UT Blade*

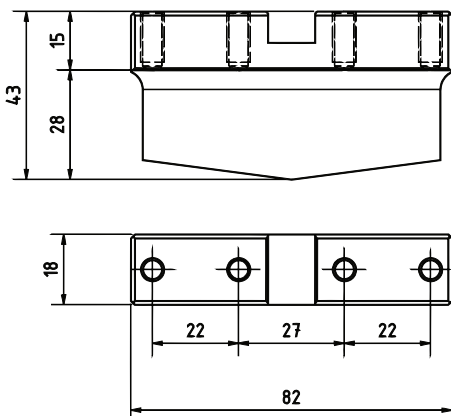

*Cuchilla WT / WT Blade*

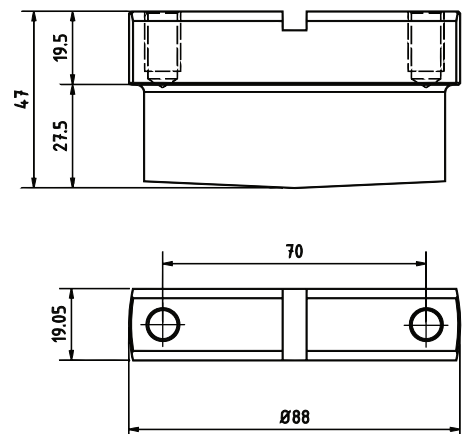



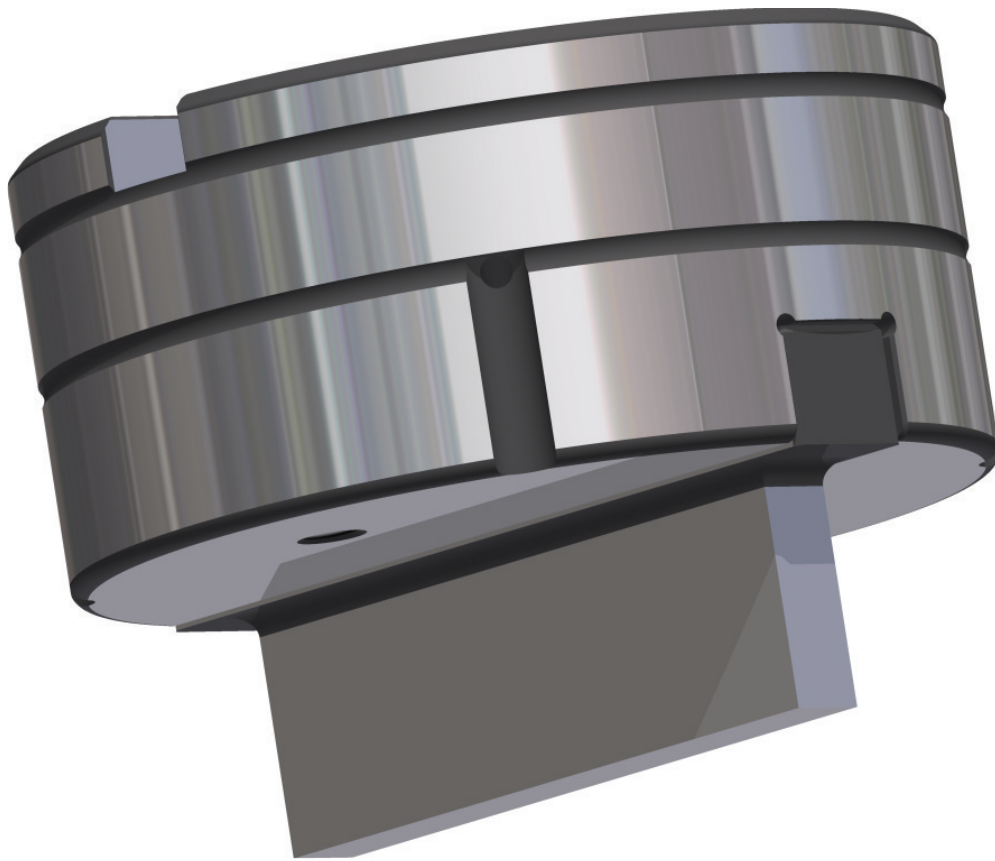

*Cuchilla TC / TC Blade*

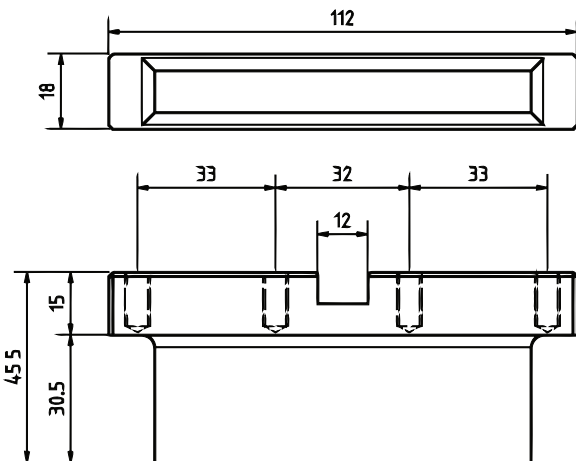

*Cuchilla WT / WT Blade*

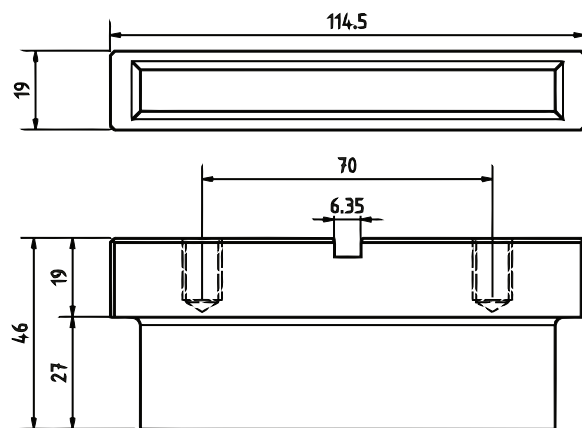

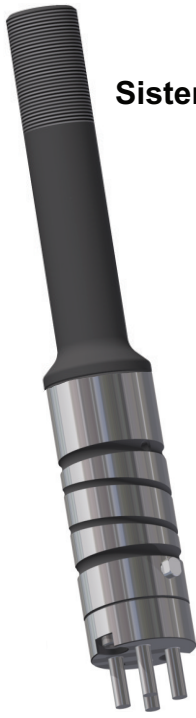

**Tipo B / Type B**  
**Sistema largo / Thick turret**

**Tipo B / Type B**  
**Sistema WT / WT system**

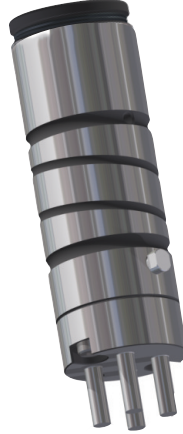

**Tipo B / Type B**  
**Sistema UT / UT system**

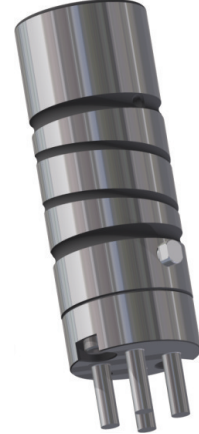

**Tipo C / Type C**  
**Sistema largo / Thick turret**  
**Sistema UT / UT System**



**Tipo D o E / Type D or E**  
**Sistema largo / Thick turret**  
**Sistema UT / UT System**



**Tipo C / Type C**  
**Sistema WT / WT system**

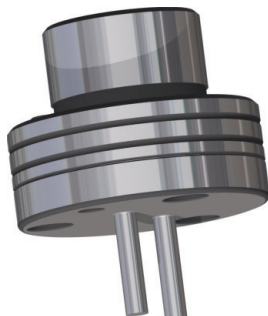

**Tipo D o E / Type D or E**  
**Sistema WT / WT system**

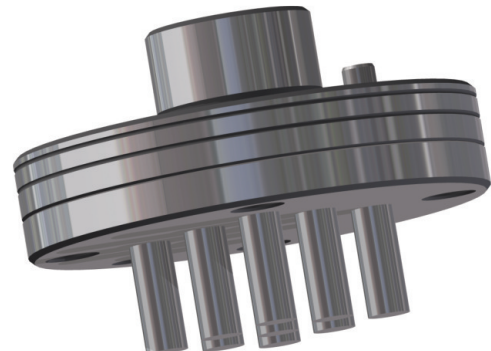

**Todos los múltiples requieren un estudio previo.**  
*All clusters needs previus study.*

## MT-10 Ø16

- Figura máxima inscrita en Ø16mm  
- Maximum shape inscribed in Ø16mm

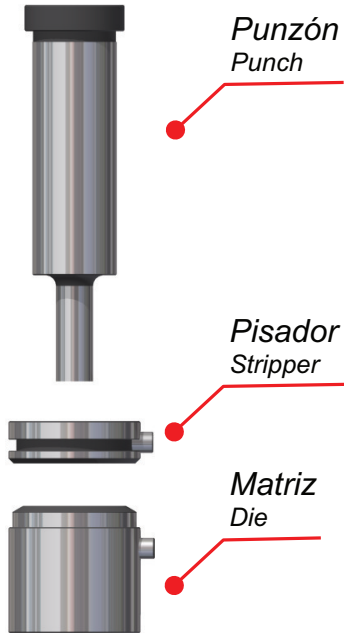

## MT-20/24 Ø8

- Figura máxima inscrita en Ø8mm  
- Maximum shape inscribed in Ø8mm

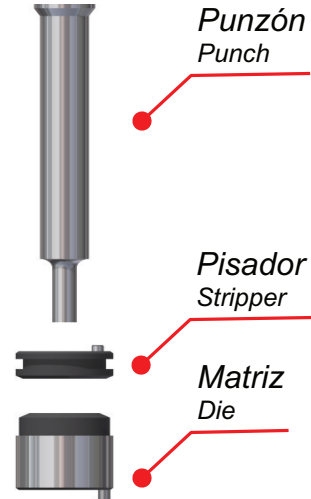

## MT-8 Ø16

- Figura máxima inscrita en Ø16mm  
- Maximum shape inscribed in Ø16mm

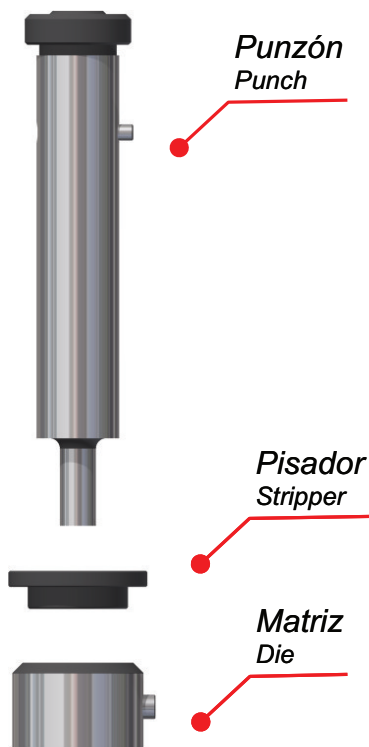

## MT-8i Ø16

- Figura máxima inscrita en Ø16mm  
- Maximum shape inscribed in Ø16mm

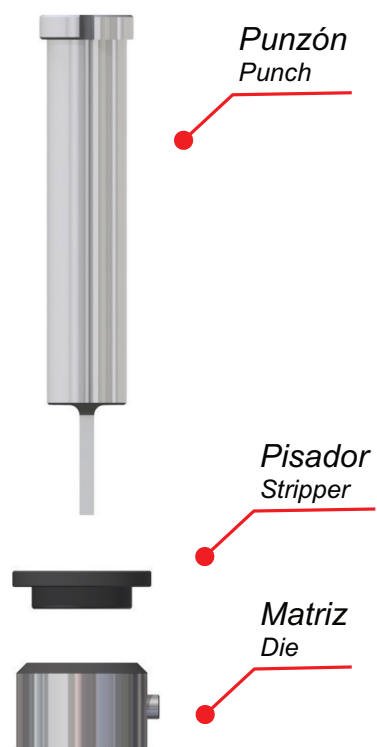



- Los avellanadores se componen de punzón+pisador+matriz
- The countersinks are composed of punch+stripper+die
- Es necesario un taladro previo al avellanado
- It is necessary pre-punch before countersink

## Avellanadores hacia abajo *Down direction countersink*

\*Todos los tipos y MT (previo estudio)

\* All types and MT (previous study)



## Avellanadores hacia arriba *Up direction countersink*

\* tipo B - C - D - MT6/8 Ø24 (previo estudio)

\* Type B - C - D - MT6/8 Ø24 (previous study)

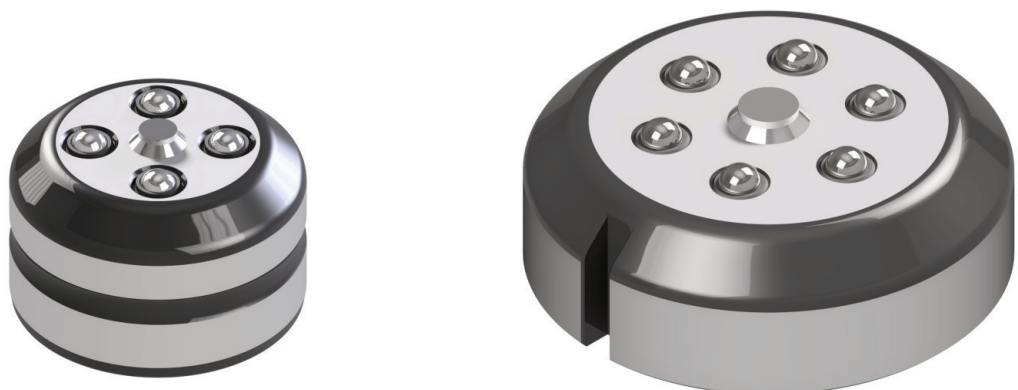



Tipo B Embutidor  
Type B Form Tool



Tipo B Roller  
Type B Roller Tool

- Roller Nervio  
*Rib Roller*
- Roller Incisor  
*Incisor Roller*
- Roller Reborde  
*Offset Roller*
- Roller Escritura  
*Marking Roller*



Tipo C Embutidor  
Type C Form Tool

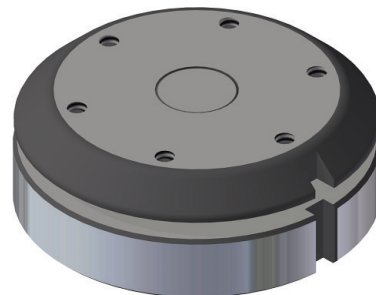

- Todos los embutidores requieren un estudio previo.
- All form tools needs previous study.*
- Figuras embutidas estándar ver pág. 21-22.
- Standard forms look at page 21-22.*
- La imagen mostrada es un ejemplo de embutidor.
- The image show is an example of form tool.*



Tipo D Embutidor  
Type D Form Tool

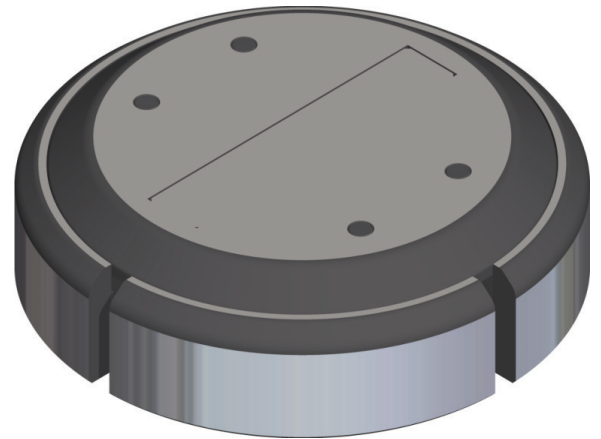

Tipo LOGOS  
Type MARK Tool



- Alto relieve y estampado.
- High relief and marking.
- Dirección tanto hacia arriba como hacia abajo.
- Up and down direction of form.
- Tamaño de tipo dependiendo del logo o forma.
- Size of type depending of the mark.

- Todos los embutidores requieren un estudio previo.
- All form tools needs previous study.
- Figuras embutidas estándar ver pág. 21-22.
- Standard forms look at page 21-22.
- La imagen mostrada es un ejemplo de embutidor.
- The image show is an example of form tool.

**Reductora de B a A  
Adapter of B to A**



**Reductora de C a B  
Adapter of C to B**

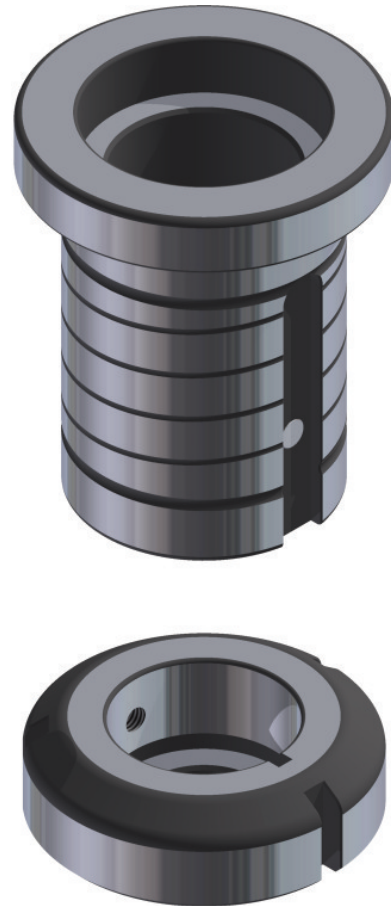

**Reductora de D a B  
Adapter of D to B**

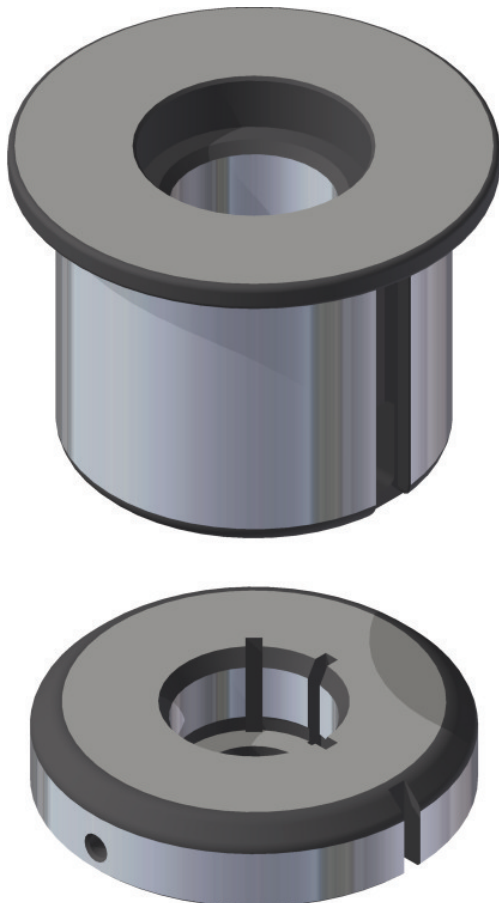

**Reductora de D a C  
Adapter of D to C**

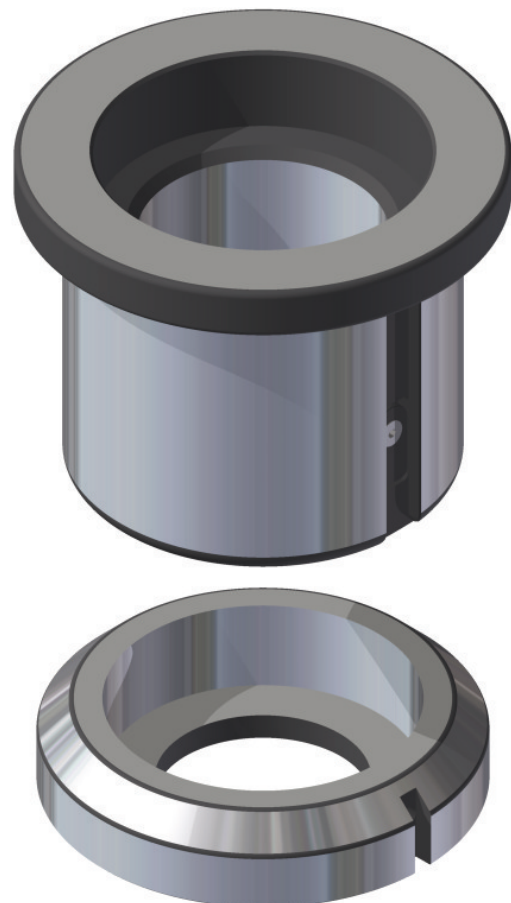



**Estación A y B Superior**  
Station A & B  
Upper Key

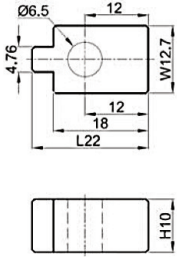

**Estación B Superior Index**  
Station B  
Upper Index Key

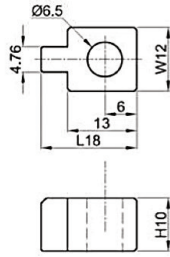

**Estación A y B Superior EM 30tn**  
Station A & B  
Upper Key EM 30tn

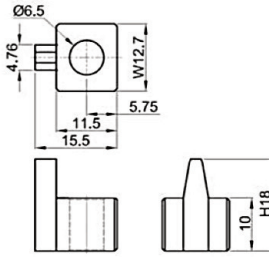

**Estación A y B Superior 100 Orbit**  
Station A & B  
Upper Key 100 Orbit

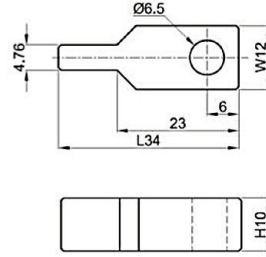

**Estación A y B Superior 300 Orbit**  
Station A & B  
Upper Key 300 Orbit

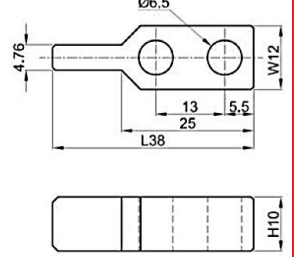

**Estación C Superior 30ST**  
Station C  
Upper Key 30ST

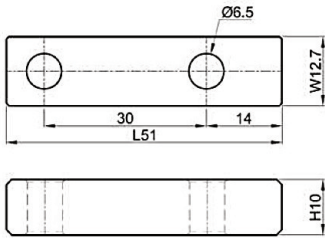

**Estación C Superior 58ST**  
Station C  
Upper Key 58ST

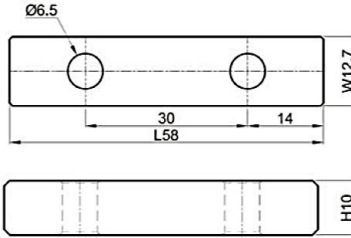

**Estación D Superior mod.1**  
Station D  
Upper Key mod.1

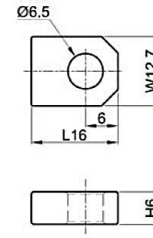

**Estación D Superior mod.2**  
Station D  
Upper Key mod.2

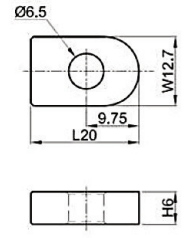

**Estación E Superior mod.1**  
Station E  
Upper Key mod.1

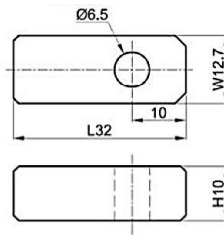

**Estación E Superior mod.2**  
Station E  
Upper Key mod.2

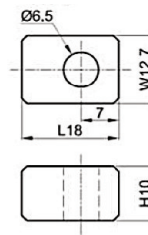

**Estación C Inferior**  
Station C  
Lower

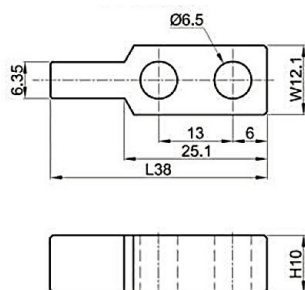

**Estación C / D / E Inferior**  
Station C / D / E  
Lower

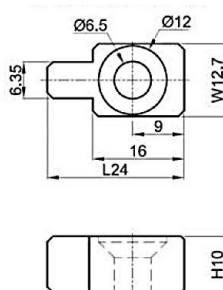

**Estación D Inferior mod.1**  
Station D  
Lower Key mod.1

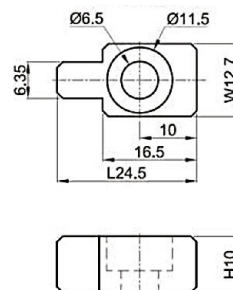

**Estación D Inferior mod.2**  
Station D  
Lower Key mod.2

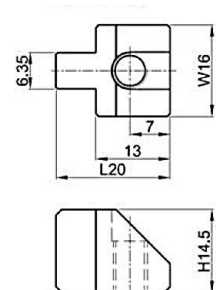

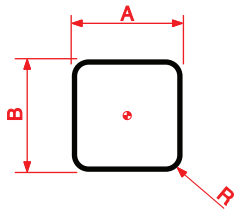

B1

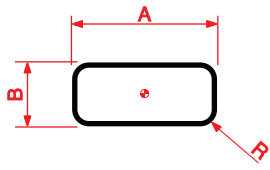

B2

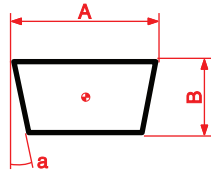

B3

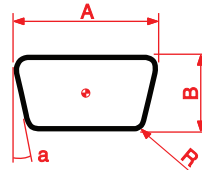

B4

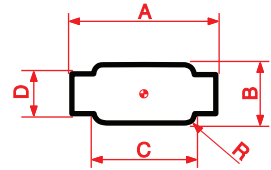

B5

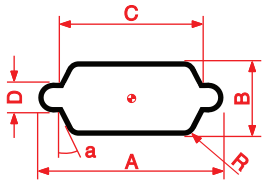

B6

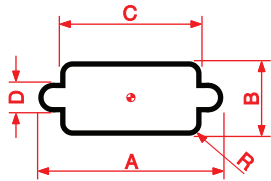

B7

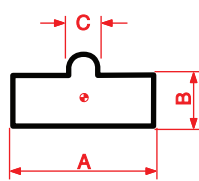

B8

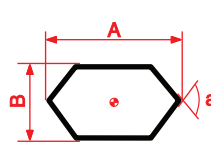

B9

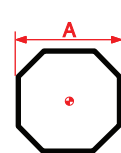

B10

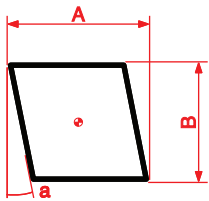

B11

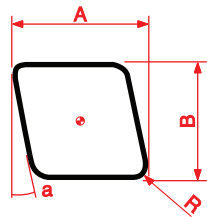

B12

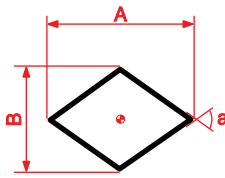

B13

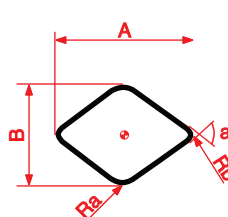

B14

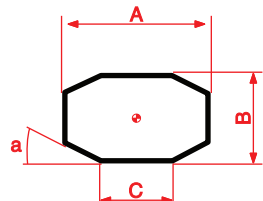

B15

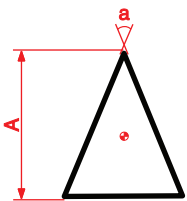

B16

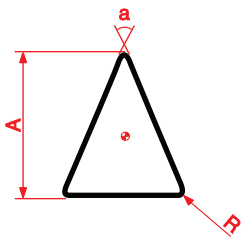

B17

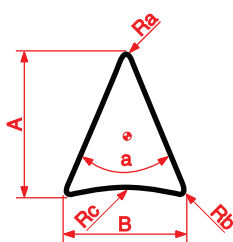

B18

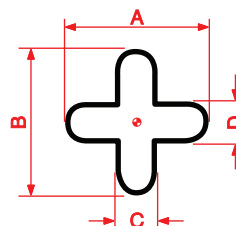

B19

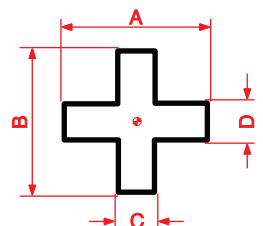

B20

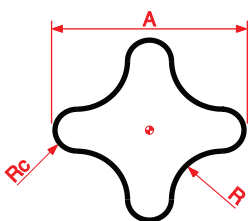

B21

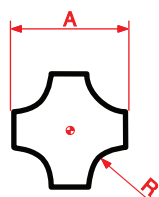

B22

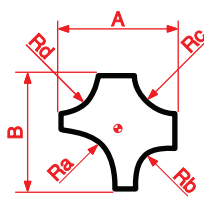

B23

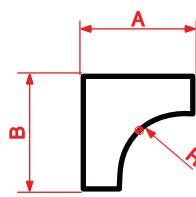

B24

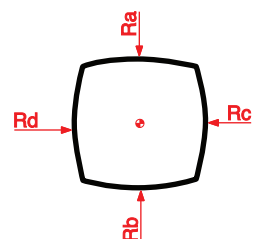

B25

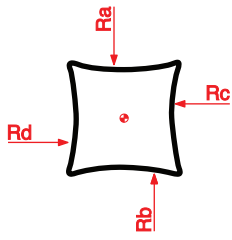

B26

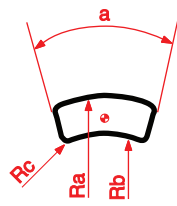

B27

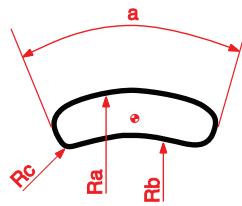

B28

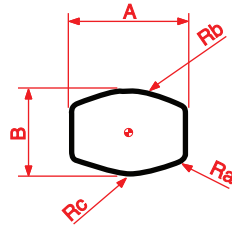

B29

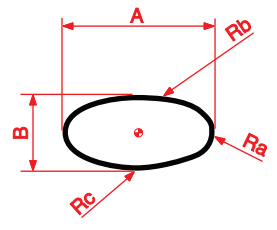

B30

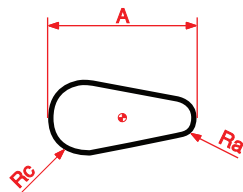

B31

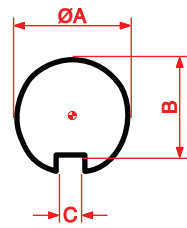

B32

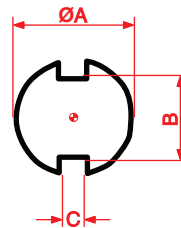

B33

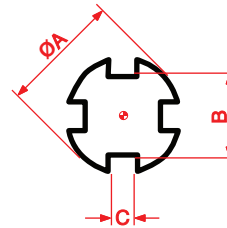

B34

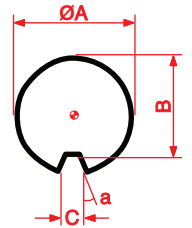

B35

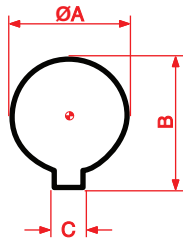

B36

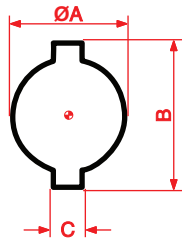

B37

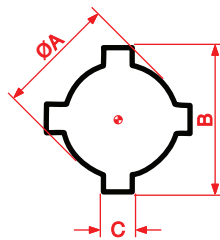

B38

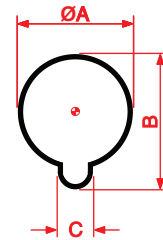

B39

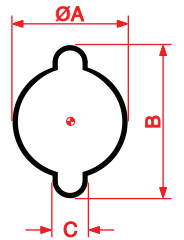

B40

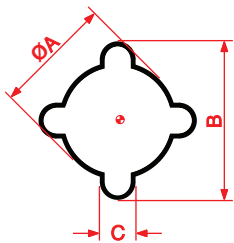

B41

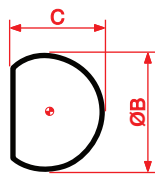

B42

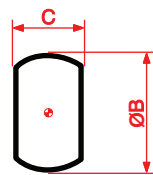

B43

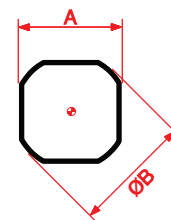

B44

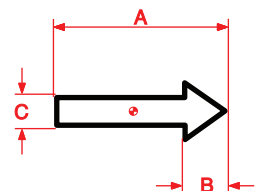

B45

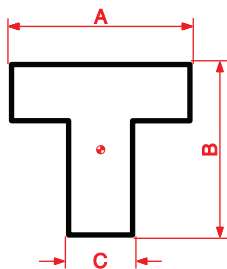

B46

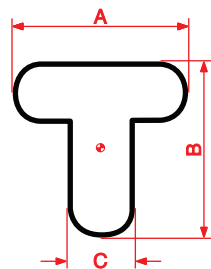

B47

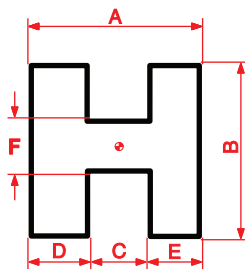

B48

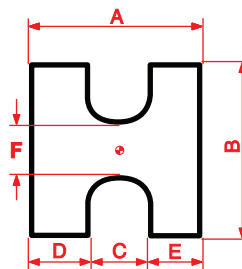

B49

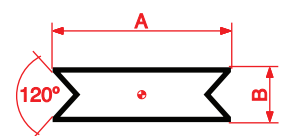

B49-A

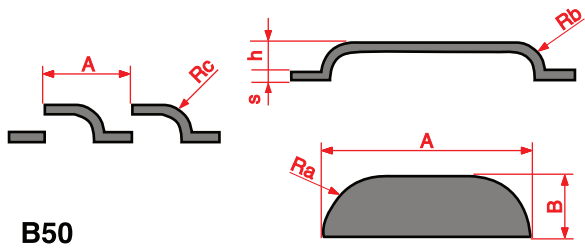

B50

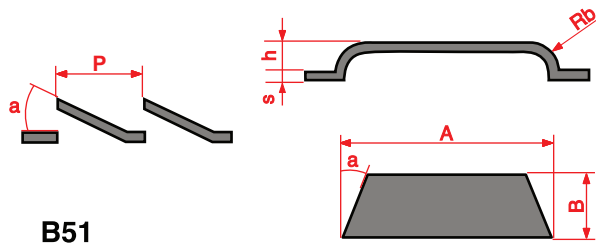

B51

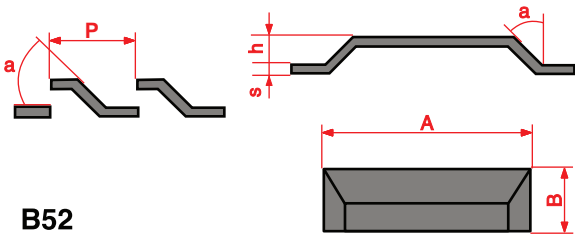

B52

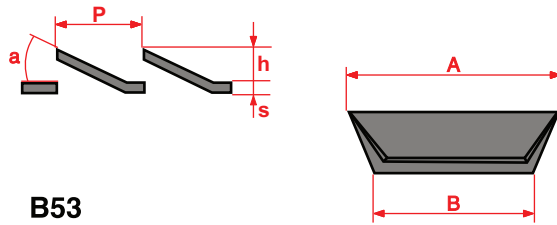

B53

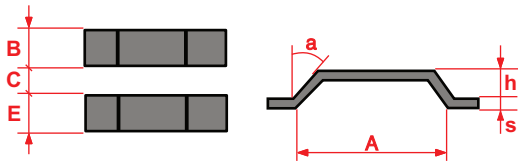

B54

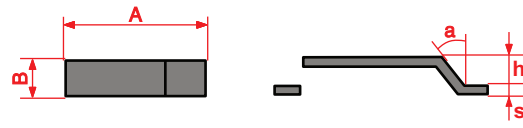

B55

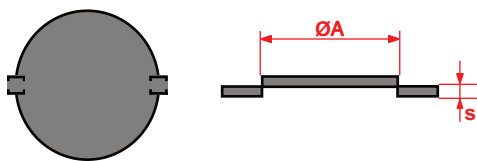

B56\*

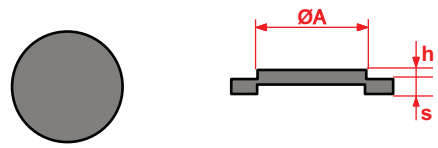

B57

\*Simple o Doble  
\*Single or double



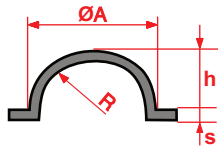
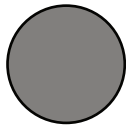

B58

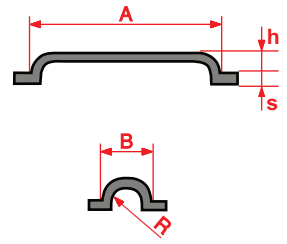

B59

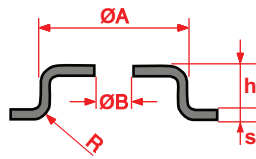
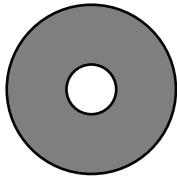

B60

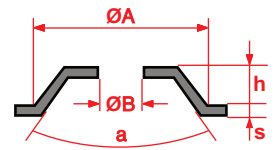
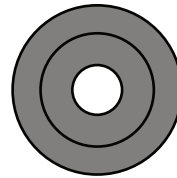

B61

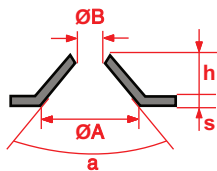
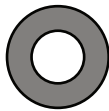

B62

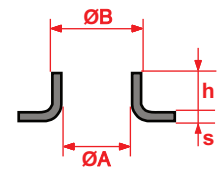

B63

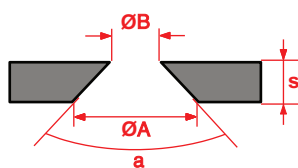
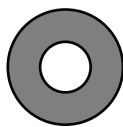

B64

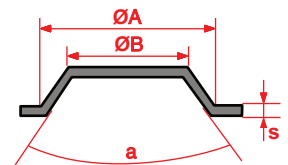
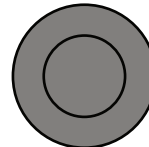

B65

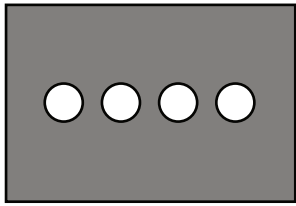

B100

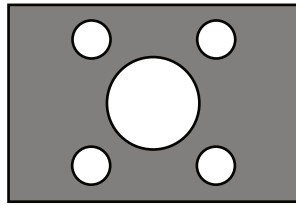

B101

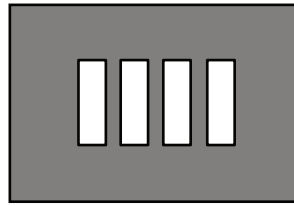

B102

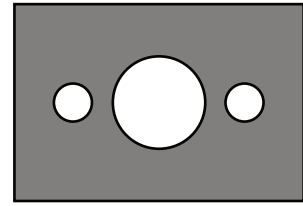

B103

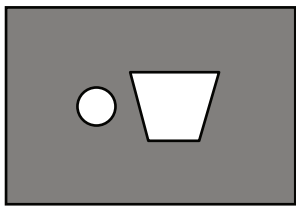

B104

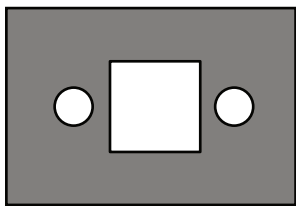

B105

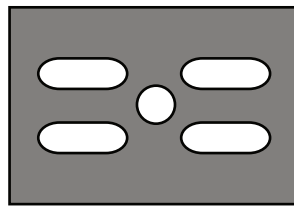

B106

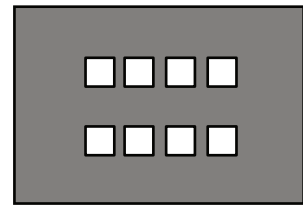

B107

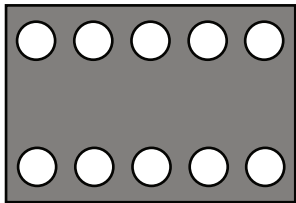

B108

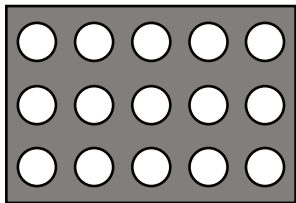

B109

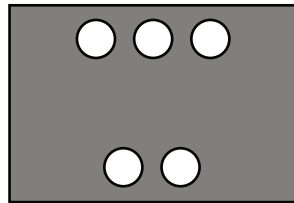

B110

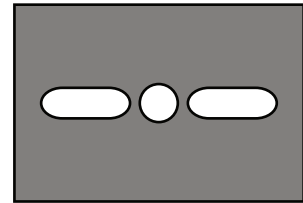

B111

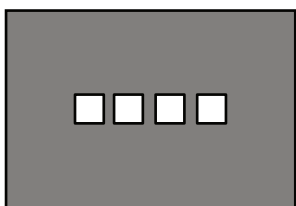

B112

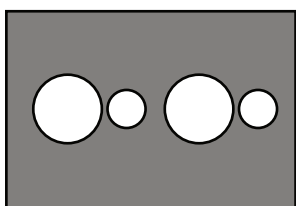

B113

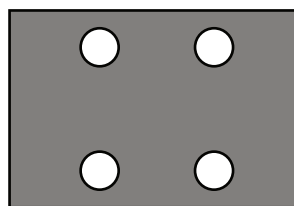

B114

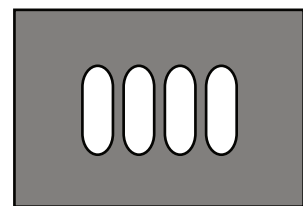

B115

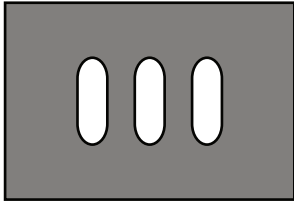

B116

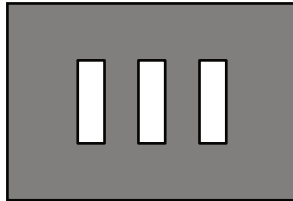

B117

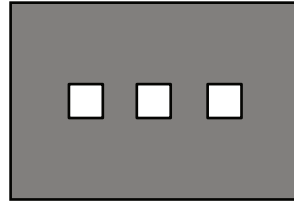

B118

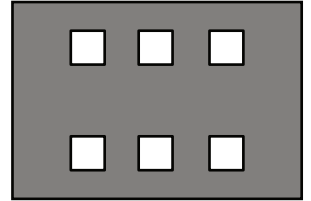

B119

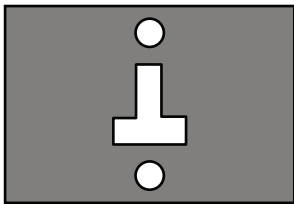

B120

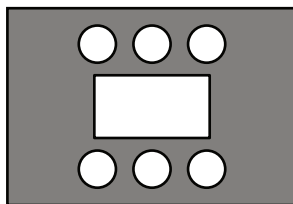

B121

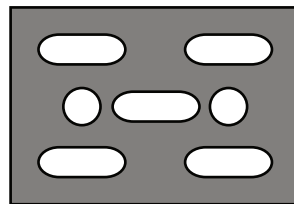

B122

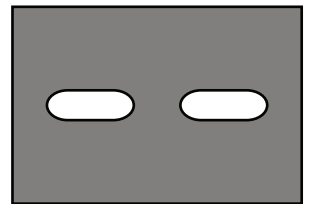

B123

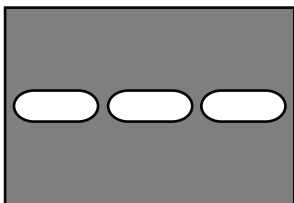

B124

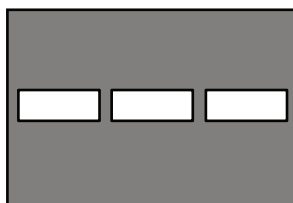

B125

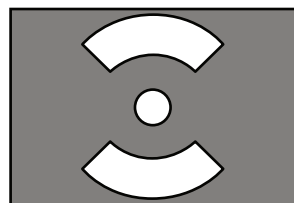

B126

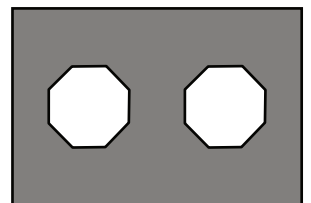

B127

## TOLERANCIAS (mm) entre PUNZÓN y MATRIZ CLEARANCE (mm) between PUNCH & DIE

Espesores en mm. Thickness in mm	Hierro / Fe Mild Steel		Ac. Inox Stainless Steel		Aluminio Aluminium		Cobre / Latón Copper / Brass	
	Tolerancia Clearance	R	Tolerancia Clearance	R	Tolerancia Clearance	R	Tolerancia Clearance	R
0,5 - 0,6	0,08 - 0,10	0,10	0,10 - 0,12	0,12	0,06 - 0,08	0,08	0,05 - 0,06	0,06
0,8	0,14 - 0,15	0,15	0,15 - 0,20	0,20	0,10 - 0,14	0,10	0,08 - 0,10	0,08
1,0	0,16 - 0,20	0,20	0,18 - 0,24	0,24	0,12 - 0,16	0,14	0,10 - 0,14	0,12
1,2	0,20 - 0,24	0,24	0,25 - 0,30	0,26	0,15 - 0,20	0,16	0,12 - 0,15	0,14
1,5	0,25 - 0,30	0,30	0,27 - 0,35	0,34	0,18 - 0,24	0,22	0,15 - 0,20	0,18
2,0	0,34 - 0,40	0,40	0,36 - 0,45	0,45	0,24 - 0,30	0,26	0,20 - 0,25	0,24
2,5	0,45 - 0,50	0,50	0,46 - 0,55	0,55	0,32 - 0,35	0,35	0,25 - 0,30	0,28
3,0	0,50 - 0,60	0,60	0,60 - 0,70	0,65	0,35 - 0,45	0,40	0,30 - 0,40	0,36
4,0	0,65 - 0,80	0,80	0,70 - 0,95	0,90	0,45 - 0,60	0,55	0,40 - 0,50	0,48
5,0	0,85 - 1,00	1,00	0,90 - 1,15	1,10	0,60 - 0,80	0,70	0,55 - 0,65	0,60
6,0	0,95 - 1,20	1,20	1,10 - 1,40	1,35	0,75 - 0,95	0,85	0,70 - 0,85	0,72

R Recomendable  
Recommended

## RESISTENCIA AL CORTE TENSILE STRENGTH

Kg x mm<sup>2</sup>

Hierro Fe Mild Steel	Hierro Fe Mild Steel	Acero Inox. Stainless Steel	Aluminio Aluminium	Cobre Copper	Latón Brass
40 (0,1 % C)	50 (0,2 % C)	70	20	32	40

## FÓRMULA PARA EL CÁLCULO DE TONELAJE (T) TONNAGE CALCULATION FORMULA (T)

$$\frac{P * n * t * Rc}{1000}$$

**P = Perímetro (mm)**  
Perimeter (mm)

**n = Número de punzones**  
Number of punches

**t = Espesor de chapa (mm)**  
Sheet Thickness (mm)

**Rc = Resistencia al Corte (Kgxmm<sup>2</sup>)**  
Tensile strength (Kgxmm<sup>2</sup>)

THICK TURRET



## Rectificado de Punzón

**A**

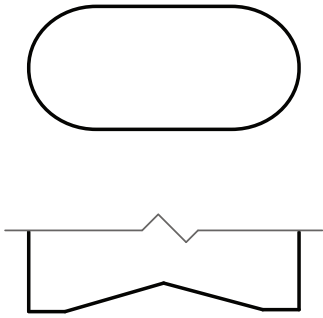

**B**

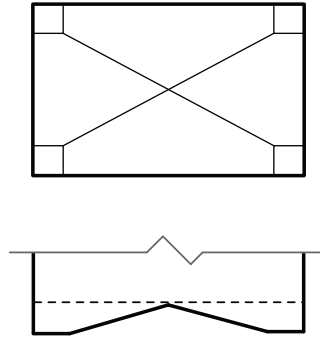

**C**

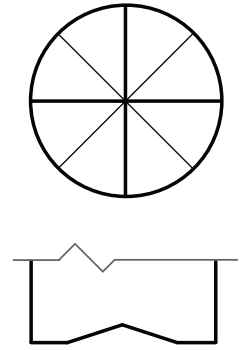

**D**

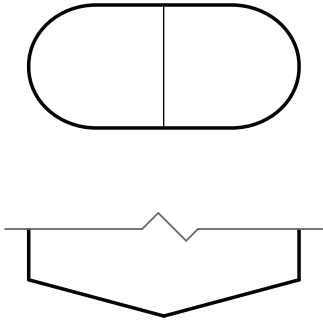

**E**

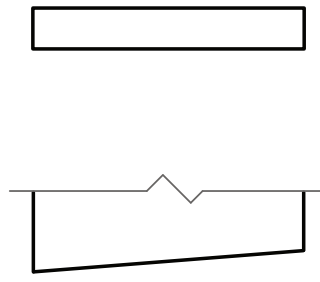

**F**

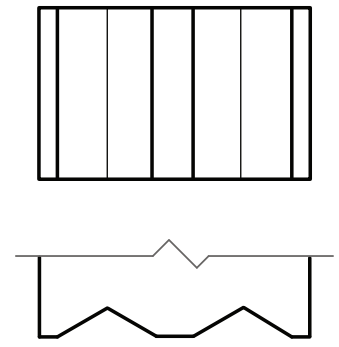

## Tipo de Matriz

**RR**

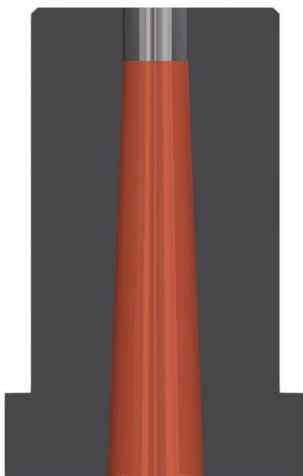

Matriz Estándar

**R2C**

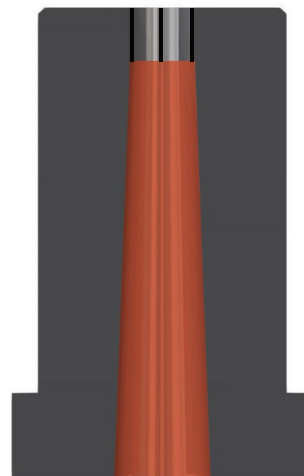

Matriz de Retención  
por Filamentos

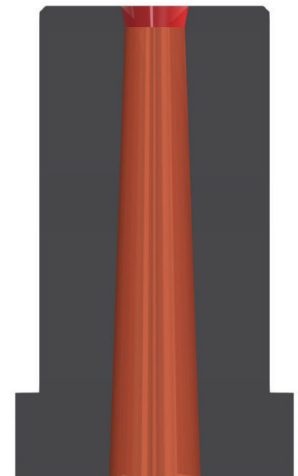

Matriz de Retención  
por Dos Conos



## **DUR-TiN**

- COLOR / COLOR: Amarillo oro / *Yellow gold*
- APLICACIONES / APPLICATIONS: General / *General*
- PROPIEDADES / PROPERTIES: Reduce el desgaste por abrasión y adhesión.  
*Reduces wear by abrasion and adhesion.*

## **DUR-ALUM**

- COLOR / COLOUR: Gris negro / *Black grey*
- APLICACIONES / APPLICATIONS: Aluminios, latón y derivados / *Aluminium, brass and derivative*
- PROPIEDADES / PROPERTIES: Reduce el desgaste por adhesión.  
*Reduces wear by adhesion.*  
Bajo coeficiente de fricción.  
*Low coefficient of friction.*  
Buenas propiedades de deslizamiento.  
*Good slip properties.*

## **DUR-INOX**

- COLOR / COLOUR: Gris violeta / *Purple grey*
- APLICACIONES / APPLICATIONS: Fe, galvanizados, Ac. inoxidables / *Fe, Fe. galvanized and stainless steel*
- PROPIEDADES / PROPERTIES: Relación optimizada entre dureza y tensión residual compresiva.  
*Optimized ratio between hardness and compressive residual stress.*  
Desgaste uniforme.  
*Uniform wear.*  
Buenas propiedades de deslizamiento.  
*Good slip properties.*

## **DUR-EXTREM**

- COLOR / COLOUR: Gris azulado / *Bluish grey*
- APLICACIONES / APPLICATIONS: General; recomendado para Ac. Inoxidable.  
*General; recommended to stainless steel.*
- PROPIEDADES / PROPERTIES: Resistencia al desgaste muy elevada y excelente dureza en caliente.  
*Very high wear resistance and excellent hot hardness.*  
Muy buena estabilidad al choque térmico.  
*Very good stability to thermal shock.*  
Velocidad de corte notablemente más altas.  
*Higher cutting speed.*

## **DUR-EXTREM PLUS**

- COLOR / COLOUR: Cromo / *Chrome*
- APLICACIONES / APPLICATIONS: General; especialmente indicado para Ac. Inoxidable.  
*General; especially suitable to stainless steel.*
- PROPIEDADES / PROPERTIES: La mayor dureza superficial.  
*The higher surface hardness.*  
Menor tendencia al calor.  
*Less heat tendency.*  
Mayor protección especialmente en los bordes contra el inicio y propagación de grietas.  
*Increased protection especially in the edges against the beginning and propagation of cracks.*  
Puede prolongar la vida útil del punzón hasta un 100%  
*Can extend punch life up to 100%.*

## **AFILADO DE LOS PUNZONES**

Como norma general, no se debería permitir que los punzones llegasen a necesitar un afilado mayor de 0,10 mm. Y sería óptimo rectificar en pasadas suaves (Z) de entre 0,01 y 0,02 mm. Estos parámetros indicarían un correcto mantenimiento de los punzones.

Para punzones con recubrimientos especiales: DUR-TiN, DUR-ALUM, DUR-INOX, DUR-EXTREM y DUR-EXTREM PLUS emplear los mismos indicadores; y dependiendo de la máquina que se utilice, rectificar con las más altas revoluciones de muela posibles y con avances entre 2.500 y 4.000 mm/min.

Una vez hecho el afilado del punzón, comprobar que la zona perimetral del corte ha quedado completamente limpia y no presenta gripado por adhesión de partículas del material punzonado, en caso de estas, limpiar esa zona con papel de lija fino hasta dejarla pulida.

## **SHARPENED OF PUNCHES**

As general norm, it's not recommended sharpening punches more than 0,10mm. The correct form to sharp is doing it with smooth feeds (z) about 0,01 and 0,02mm. It will be the correct maintenance of the punches.

For punches with special coatings: DUR-TiN, DUR-ALUM, DUR-INOX, DUR-EXTREM and DUR-EXTREM PLUS, use the same indicators; using the highest revolutions of the grinding wheel for shapening, with feed rates between 2.500 and 4.000 mm/min.

Once realised the sharpened of the punch, verify that the peripheral zone of the cut is completely clean and if it's necessary polish the surface with a lightly stone.

*Important: to avoid the heating of the pieces during the sharpening, always use a suitable coolant.*

## **AFILADO DE MATRICES**

Manteniendo las matrices en corte vivo, alargará la vida de los punzones, pues éstos no tendrán que embutir la chapa antes de ser cortada, se evitarán rebabas, ruido excesivo y se dejará una calidad correcta en el corte.

Sirven los mismos parámetros de muela, avances y pasadas tanto en el punzón como en la matriz; y antes de dar por bueno el afilado de la matriz, comprobar que en la parte interior del perímetro de corte, no han quedado restos de partículas de chapa adheridas, que vayan a friccionar con el puzón al iniciar de nuevo el trabajo.

Evitar el calentamiento de las piezas, usando siempre un refrigerante adecuado o taladrinas.

La energía producida por la fricción de la muela con los aceros, hará que estos hayan quedado ligeramente imantados; desmagnetizar las herramientas antes de iniciar el trabajo.

## **SHARPENED OF DIES**

The correct maintenance of the dies will extend the life of punches, because these will not emboss the sheet before being cut, it will avoid burrs and excessive noise, and it give a correct quality of the cut.

For sharpening dies used the same procedures that with punches, feed rates and griding wheel, verify that the cut zone is completely clean of burrs and if it is necessary polish it to assure the correct work of the punch.

To avoid the heating of the pieces, always use a suitable coolant.

Demagnetize the resharpened tools before to start works.

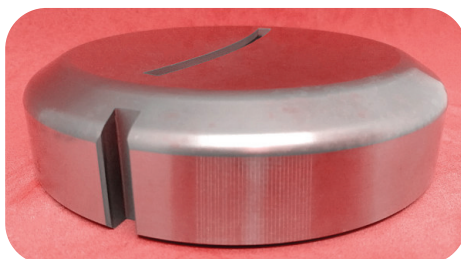

## Servicio y Reparación

El servicio de reparación y ajuste de TC consiste en la comprobación, reparación, ajuste o modificación de cualquier componente fijo, móvil y/o accesorios de todo tipo de grupos de punzonado, matricería e incluso componentes de máquina sin importar marca y modelo.

### Comprobación

Revisión de todos los elementos, comprobación de los mismos (medidas, chavetas, tornillo, etc.)

### Reparación

Sustitución de cualquier elemento que interfiera en el buen funcionamiento del grupo, tanto por desgaste como por rotura.

### Ajuste

Ajustamos los grupos para su correcto funcionamiento modificando alturas, recorridos, etc.

### Modificación

Estudiamos la posibilidad de modificaciones y cambios en grupos de punzonado y matricería, realizando elementos nuevos y/o modificando los ya existentes.

## Service & Repair

Tc's adjustment and repair consist of checking, repairing, adjusting, or modifying any fixed and mobile component and / or accessories of all types of punch groups, dies and even machine components of all brands.

### Verification

Review all elements, checking them ( measurements, keys, screws, ...).

### Repair

Replacement of any element that interferes with the proper fuction of group for breakage and / or attrition.

### Adjustement

We adjust the groups for their correct operation by modifying heights, courses, ...

### Modification

We study the possibility of modifications and changes of punch groups and tooling, making new elements and / or modifying existing ones.







*Solutions for Metalworking*

[www.tcpunzones.com](http://www.tcpunzones.com)

**Thick Turret system**

**Goiti<sup>®</sup> - Danobat<sup>®</sup> system**

**Euromac<sup>®</sup> system**

**Trumpf<sup>®</sup> system**

**Salvagnini<sup>®</sup> system**

**Especiales y Accesorios**

**Plegadora**

**Láser**

**Tlf. +34 934 228 023**  
**info@tcpunzones.com**

