

TopSolid

Tooling

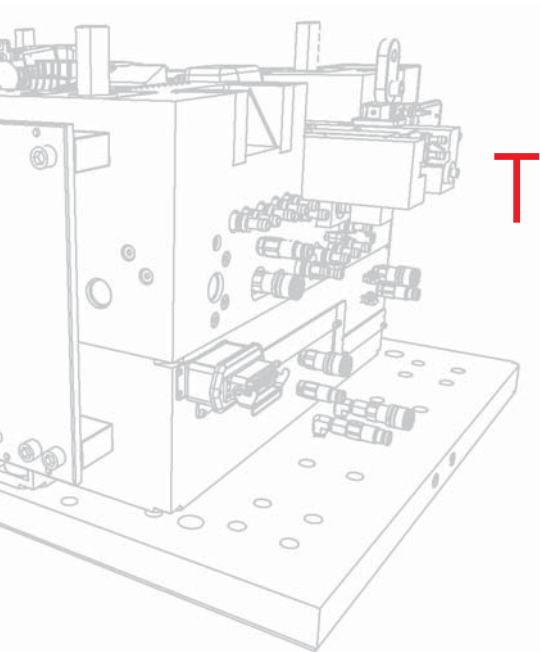

THE COMPLETE CAD/CAM
SOLUTION FOR THE
TOOL & DIE INDUSTRY

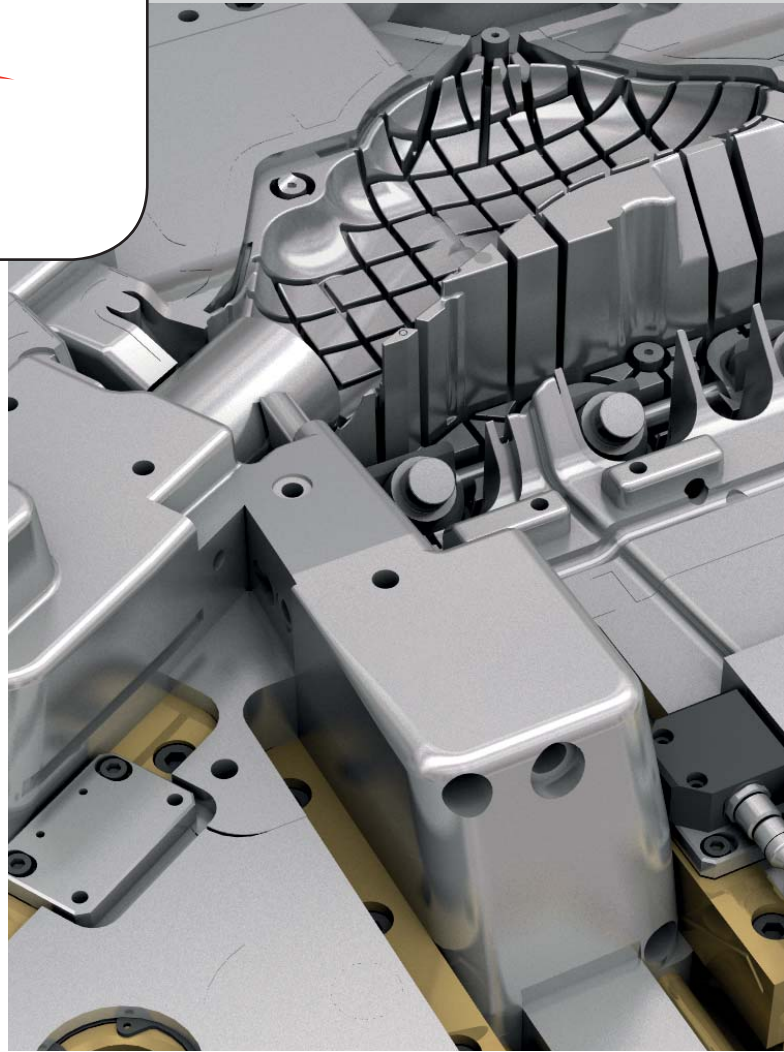
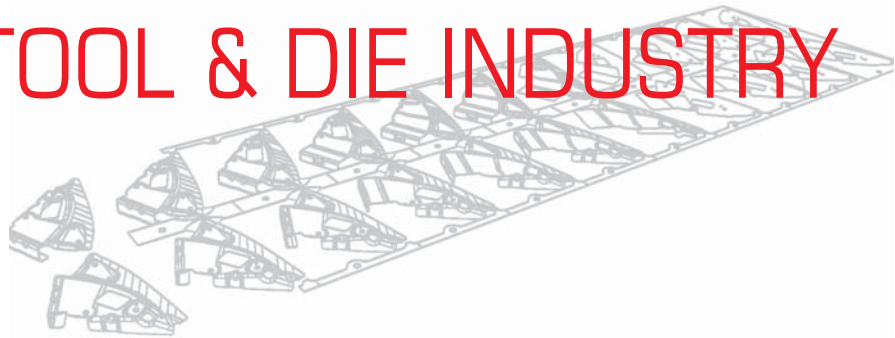

MASTER YOUR
MANUFACTURING PROCESS

CAD/CAM FOR TOOLING SPECIALISTS

With TopSolid' Tooling (which groupstogether TopSolid' Mold, TopSolid' Progress and TopSolid' Electrode) Missler Software offers powerful tool design and manufacturing solutions for mold and die makers. These integrated TopSolid modules for the tool and die industry cover the complete digital chain, from design to simulation and manufacturing.

This exceptional software allows you to:

- > Easily work with your customers data
- > Repair, adapt and edit this data so that you can begin designing as quickly as possible
- > Use both industry standards and user defined components with ease
- > Take into account and simulate material deformations and retraction which are vitally important when developing a tool
- > Simulate the mechanics of the tool and detect any possible collisions
- > Directly machine what is designed while taking the manufacturing process (grinding, electrode erosion, etc.) and all the associated tolerances into consideration

With its strong experience in tool and die manufacturing, Missler Software pays close attention to the specific needs of toolmakers. Thanks to our wealth of specialized solutions, you can completely design your tools in 3D and control all constraints before producing the drawings. Changes made to the design at any stage of the product lifecycle are no problem to manage thanks to TopSolid's associativity. You will save time and benefit from improved security.

Prepare your design

Importing external data is a key step in the design of any tool. TopSolid can directly exploit the following formats: Parasolid, IGES, Catia v4 & v5, Pro-E, UG, STEP, SolidWorks, SolidEdge, ACIS, DXF, DWG, STL and VDA. In addition to its data recovery capacities TopSolid has correction tools to isolate and repair geometrical problems often associated with imported external data. (fill in holes, sewing functions, adjust continuity, ...)

A design process based on standards and components

TopSolid includes a library of thousands of preset mold components. You can use standard mold bases, ejectors, rails, nozzles, and columns in close cooperation with suppliers like DME, Meusburger, Polimold or Misumi. You can easily retrieve all 3D data, automatically calculate the parting lines and easily incorporate the cooling circuits while avoiding collisions.

Collaborative design

Tools can be designed in a collaborative environment by sharing the workload between several users in order to reduce the length of the design cycles. A general assembly is available at all times to completely assemble the project in order to check and view the results of each user and to provide a reference for drafting and machining.

Simultaneous and remote working

TopSolid can also manage the conflicts resulting from changes that are made simultaneously to the same part or subassembly. The effective control of desynchronization also allows remote users to work on the same project. Your projects benefit from enhanced comfort, flexibility and performance!

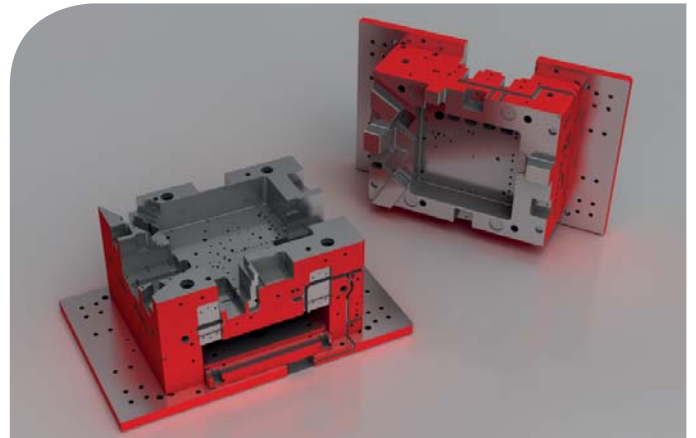

A CAD/CAM software dedicated to tool design.



TopSolid*Mold being used by company Taulou (France) for plastic injection mold design.

SPECIALIZED CAD/CAM FOR MOLD MAKERS

TopSolid'Mold has all the functions needed to create molds, while halving the time taken to design a mold in comparison with generic design applications. Its functions to create parting lines and surfaces, wizards to install standard and preset components plus its fully integrated and associative drafting function all help to rationalize the design process of your tools, while taking your manufacturing imperatives into consideration.

TopSolid'Mold significantly boosts productivity thanks to the management of part changes to be molded during the design process.

No matter which field of activity you work in, from plastic injection to aluminum molds, thermoforming and blow-molding, TopSolid'Mold is a powerful tool that is well adapted to your needs.

TopSolid'Mold is a fully integrated CAD/CAM module designed to meet the highly demanding and specialized needs of mold makers and tool & die specialists. The complete mold design and machining process is fully managed including all changes which may occur throughout this stage. TopSolid'Mold offers incredible productivity gains thanks to its complete integration and mold making specialized functions.

TopSolid'Mold speeds up the design of core cavity blocks

- > Global or differential control of indent factors
- > Rapid analysis of drafts and back drafts of plastic parts
- > Automatic detection of parting lines
- > Assisted creation of parting surfaces

TopSolid'Mold adapts to your working methods

- > Preliminary study mode for quick quotes
- > Incorporation of changes to parts in the design process
- > Management of multiple core cavity blocks and versioned molds

TopSolid'Mold helps you define all moving parts

- > Library of mold bases (standard or custom)
- > Installation of the standard components required to define the movement (e.g. slides, pins, upward adjusters)
- > Automatic adjustment of components to respect the defined path

TopSolid'Mold for optimal creation of cooling circuits

- > Using 3D contours to define regulation operations in the necessary parts
- > View of circuits and collision checks
- > Automatic positioning of regulation components

TopSolid'Mold simplifies the definition of different runners

- > Positioning wizard for injection points
- > Creation wizard for runners
- > Calculation of the injection cross-sections and adjustment of

the injection point

- > Rheological analysis thanks to the advanced interface with Cadmould

TopSolid'Mold quickly produces drafts for moldmakers

- > Injection/Ejection views, local cutaways
- > Automatic dimensioning of drill holes
- > Structured parts lists, adapted blistering

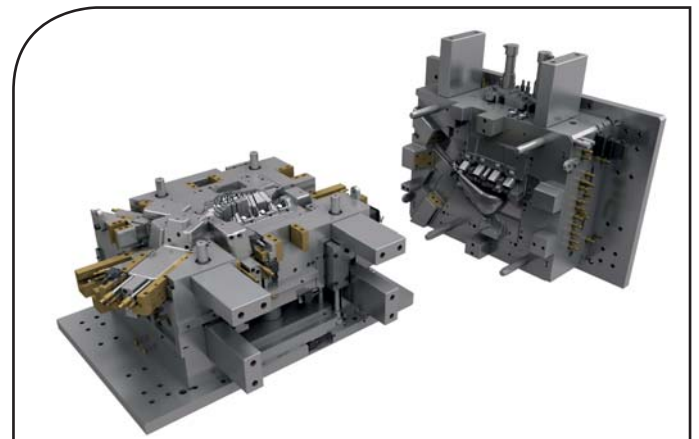

Design your mold and machine your mold base with TopSolid'Mold.

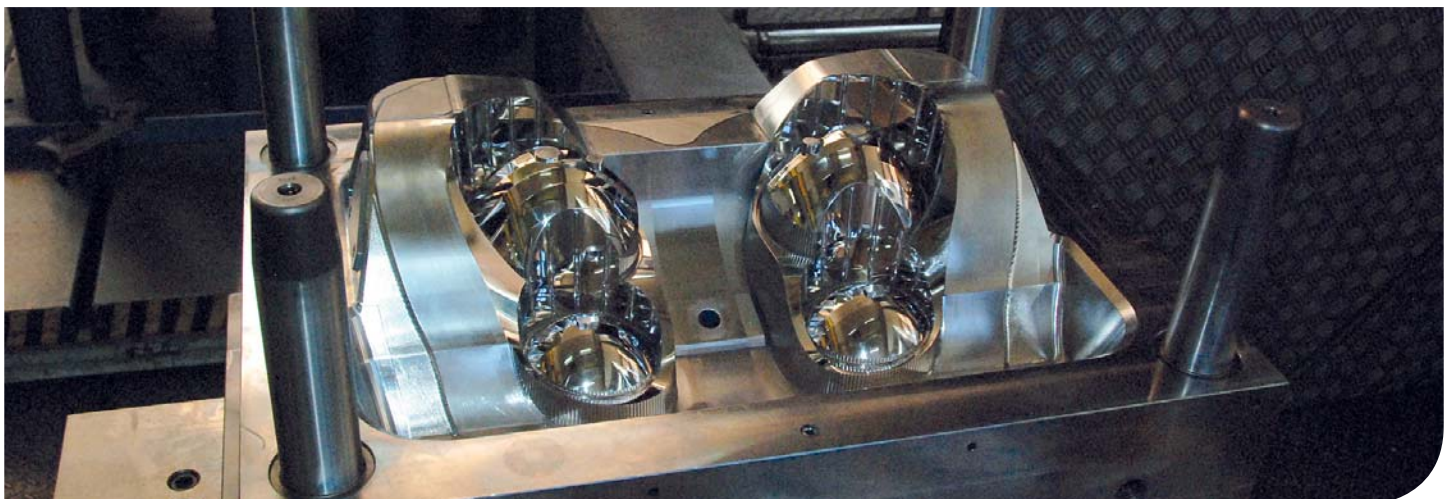

The design of a part for the automobile industry with TopSolid'Mold.

A BOOST FOR YOUR ELECTRODES

Since it can easily work with external data, TopSolid'Electrode is the logical extension of TopSolid'Mold. It can be used to retrieve core cavity blocks, while masking the operations that require conventional machining.

TopSolid'Electrode helps you to create your electrodes, from production to workshop maintenance. This application is supplemented by TopSolid'Wire, which can be used to calculate the paths for wire EDM machines.

This software suite is the essential companion of your CAD/CAM system, thanks to the precious time it saves and the enhanced dependability of the process.

Once the 3D tool design process is complete, it is often necessary to design and build dozens of electrodes which can become a repetitive and painstaking process. In addition to efficiently designing your electrodes, TopSolid'Electrode also guarantees that they are compatible with all the specific characteristics resulting from EDM machining.

Quick and efficient creation

- > Creation wizard by type of electrode
- > Help to select the zones to be eroded
- > Automatic extension of tangential surfaces
- > Gap management: roughing, semi-finishing, finishing
- > Standard and/or custom attachments
- > Libraries of standard components (Erowa, System 3R)
- > Automatic workshop drafting
- > Automatic calculation of flow and control

Keeping the thread of machining

TopSolid'Wire can take a 2D or 3D definition (wire, surface or volume) and produce adapted and optimized machine code in record-breaking time, from straight cuts to 4-axis mode.

- > Automatic offset of Z-shaped sections
- > Surface and draft recognition
- > Marking out of configurable entities
- > Roughing by destruction
- > Machining strategies that incorporate the machine technology
- > Loop, stop and corner condition management
- > Optimized sequencing of paths
- > Management of day/night strategies, with automatic wire threading and cutting

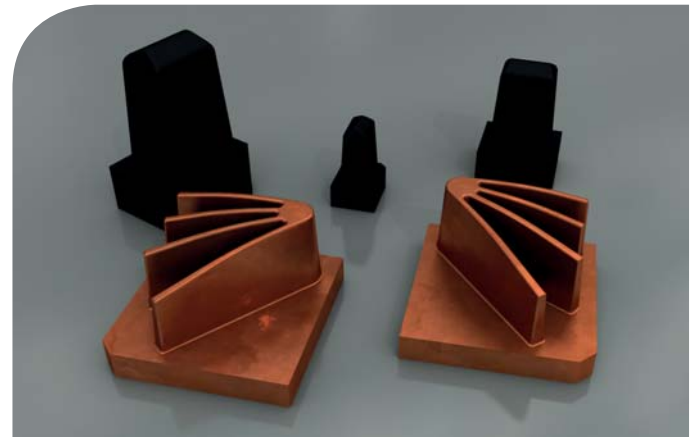

Design and manufacturing of electrodes with TopSolid'Electrode.



TopSolid'Electrode automates the design and draft generation of electrodes and generates impressive time gains.

SPECIALIZED CAD/CAM FOR PRESS TOOLMAKERS

Along the same lines as TopSolid'Mold, TopSolid'Progress is the specialized TopSolid module for the design of progressive cutting and press tools. With its flattening tools, you can combine unfolding and unstamping operations. Simple operations (cutting, folding, shearing and forming) are processed immediately, while the processing of complex operations (stamping/unstamping) is powerful and pragmatic.

Stations can be inserted or removed at any time, and all the changes made to a model part are automatically propagated to all the stations. Assembly of die bases, guides, attachments and other standard parts can be customized and reused in the form of a library, thereby allowing designers to concentrate on the active parts of the tool.

Document creation functions include the production of overall drawings, parts lists and drawings of details with tolerances and drilling tables.

TopSolid'Progress features all the functions required to flatten parts and design the strip and the tool much more quickly than with a generic tool. Its native and complete integration with TopSolid'Cam and TopSolid'Wire allows for manufacturing without any conversions or loss of data, while making full use of all the information defined in the CAD/CAM process.

TopSolid'Progress makes strip design easier

- > Unfolding (with management of losses in folds) and unstamping (Autoform OneStep technology)
- > Specialized cutting, folding, deforming and shearing operations
- > Step-by-step calculation of intermediate forming and unstamping steps (Autoform OneStep technology)
- > Calculation of multi-pass cylindrical stamping and supports
- > Effort calculation

TopSolid'Progress capitalizes on your work

- > Standard die bases and customizable die base assembly libraries
- > Library of standard specialized components by supplier: guides, attachments, cut-outs, pilots, springs, accessories
- > Automatic machining with parts in contact, customizable play

TopSolid'Progress improves the quality of your engineering

- > Punches and cutting matrices, management of play, release of cut-offs
- > Folding punches and matrices, advanced management of overbending
- > Deformation punches and matrices
- > Kinematics wizard with collision detection

TopSolid'Progress reduces your time-to-production

- > Collaborative design methodology
- > Strip drawing, cut out zones, pilots, notes describing the operations

- > Overall drawings (standard views or open book), interruption of sections to check the heights
- > Automatic detail drawings, dimensions with tolerances, drilling tables

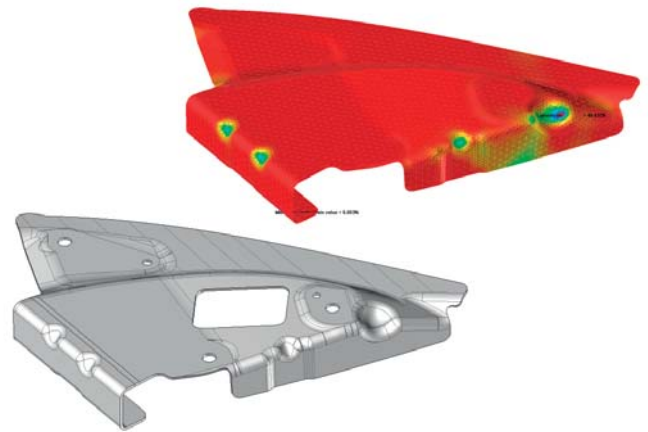

AUTOFORM
Forming Reality

The design of progressive tools with TopSolid'Progress



Very fast modeling and strip creation.

ASSOCIATED MACHINING OF PLATES AND CORE CAVITY BLOCKS

Parts designed in 3D can be machined directly using the TopSolid'Cam and TopSolid'Wire CAM modules, without necessarily having to re-enter the geometry data in the workshop, or generating a draft in the Manufacturing Methods Department. These CAM solutions offer machining functions that can process all the parts of a mold.

TopSolid'Cam proposes a broad range of machining strategies designed to cut machining times, while producing almost perfect surfaces.

All tool paths generated support high-speed machining (HSM) options. TopSolid'Cam can manage trochoidal machining, roughs by plunge cuts and so-called constant-peak paths.

Finished products must reach the market as quickly as possible. Therefore, tools must be made as quickly as possible too. The topological analysis of the models, which is based on a perfect knowledge of the machining processes according to the geometry of the part, helps to guide the operator towards the right machining strategy very quickly.

Up to 5 axes in 3D

TopSolid'Cam is capable of machining 3 or 5 axis core cavity blocks with orientation management to avoid collisions and also offers tool libraries and optimized feed rate management. TopSolid'Cam can take account of the shape of the tools and their attachments when calculating the paths. TopSolid'Cam can be used to automate the production processes of holes, pits, slider housings, etc.

Ultra-powerful and reliable algorithms

TopSolid'Cam uses powerful algorithms that are capable, for example, of roll machining a warped surface, even if it cannot be developed. These algorithms, which are usually long and require a lot of resources, are parallelized in order to make the most of today's multi-core processors.

A user-friendly interface

The context-sensitive menus, dynamic changes to settings, subject/verb or verb/subject mode, copy and paste, path preview before validation and advanced simulation all mean that TopSolid'Cam is easy to learn and use, even for the uninitiated.

Post-processors

TopSolid'Cam features high-performance post-processors developed by a specialized team that cooperates closely with machine tool manufacturers. These post-processors can easily be customized by Missler Software, the reseller or customers themselves.

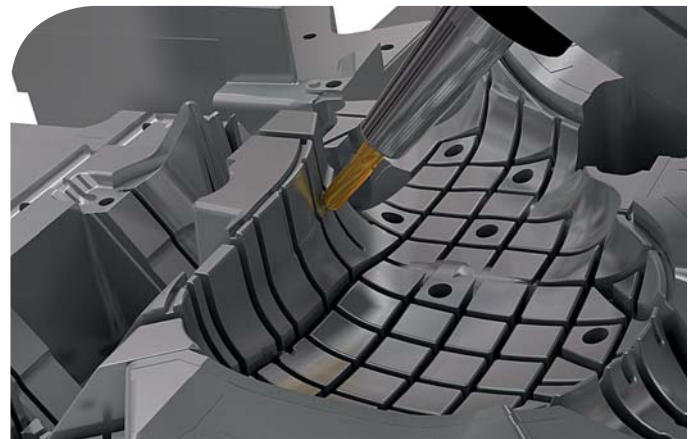

5 axis machining of a mold with TopSolid'Cam.

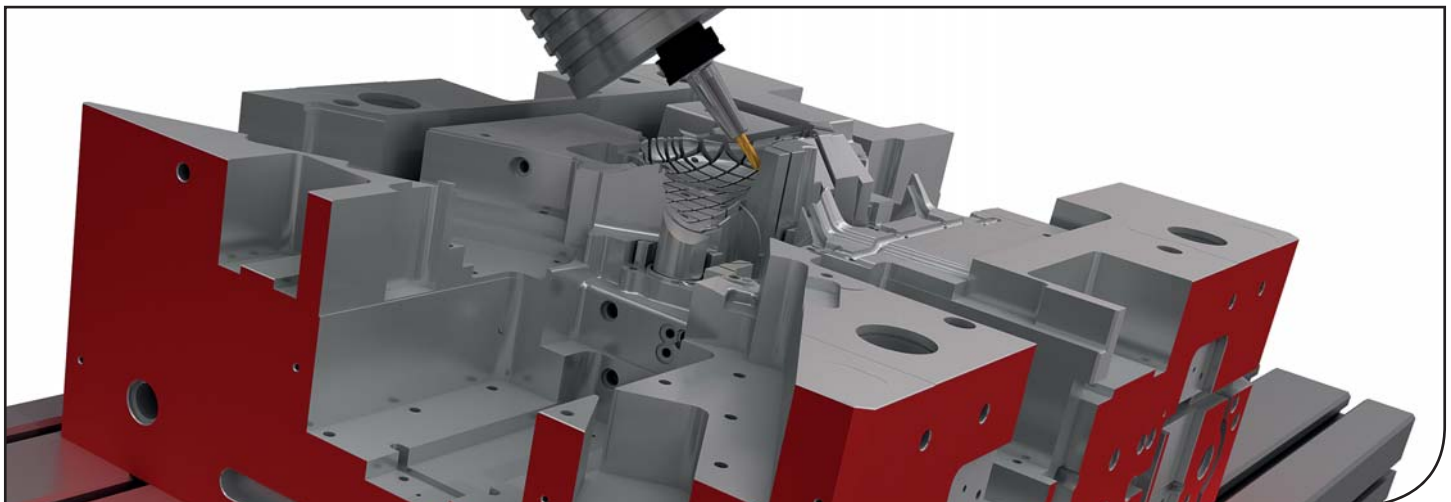

TopSolid'Cam offers several machining strategies for mold makers to reduce machining times and assure optimal surface quality.

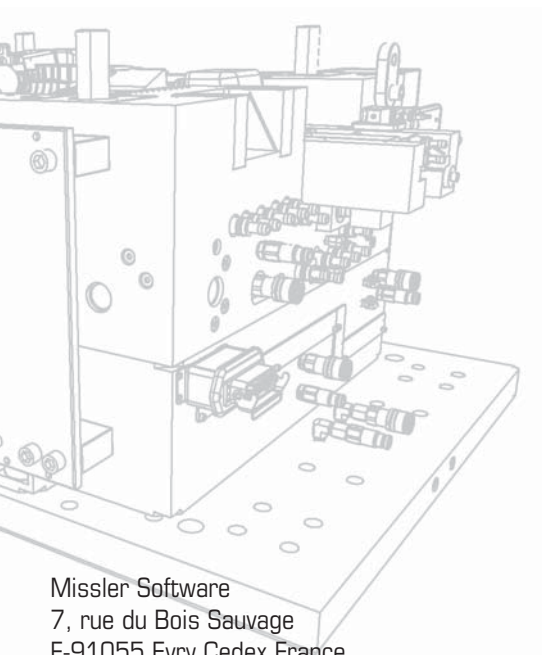

Missler Software
7, rue du Bois Sauvage
F-91055 Evry Cedex France
Tél. : +33 (0)1 60 87 20 20
Fax : +33 (0)1 60 87 20 30
E-mail : info@topsolid.com
Web : www.topsolid.com

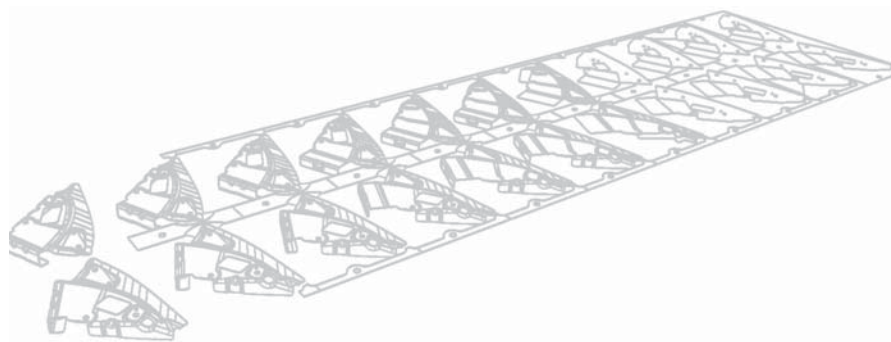

MASTER YOUR
MANUFACTURING PROCESS