

PROMO PROMO



PROMO PROMO

2012

MC

CLAK SYSTEM, attacco non magnetico.
CLAK SYSTEM, not magnetic connection.

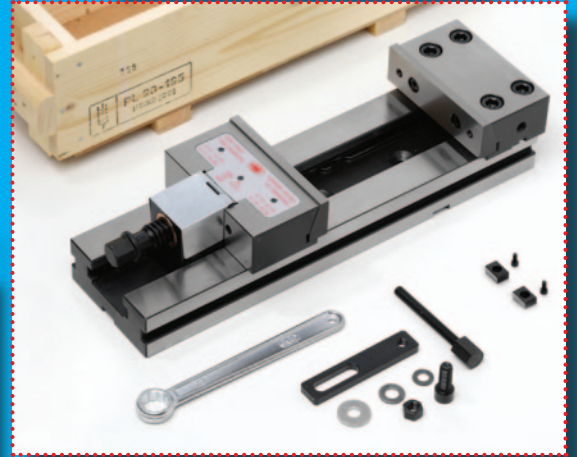
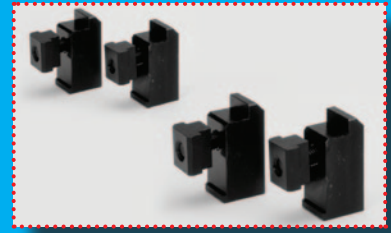

Cod. Nr.	Prezzo.Price	Offerta.Offer
33 58 06 21	€ 1.257,00	€ 933,00
33 58 06 22	€ 1.307,00	€ 1.014,00
33 58 06 23	€ 1.539,00	€ 1.075,00
33 58 07 21	€ 2.126,00	€ 1.805,00



LC

Cod. Nr.	Prezzo.Price	Offerta.Offer
77 58 95 01	€ 546,00	€ 449,00
77 58 96 01	€ 654,00	€ 540,00
77 58 96 02	€ 751,00	€ 599,00
77 58 97 01	€ 1.328,00	€ 1.100,00
77 58 97 02	€ 1.652,00	€ 1.350,00

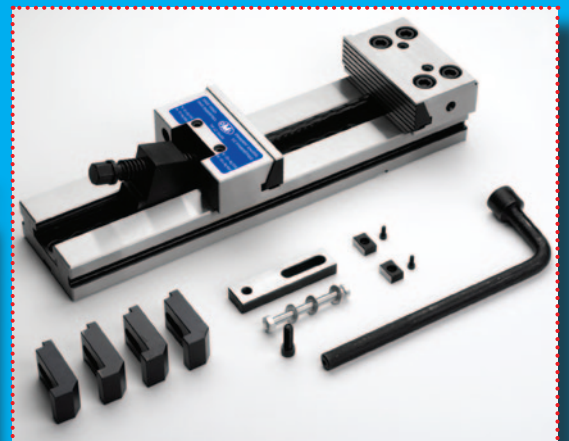

Attrezzatura di bloccaggio **MC** con: chiave poligonale, ganaschia guidata (a richiesta ganaschia oscillante), piastrina di fermo laterale, coppia chiavette di posizionamento **h6** a scelta, carter protezione vite, 4 staffe di fissaggio, coppia parallele, cassa imballo in legno.

Clamping equipment **MC** complete with: wrench, rigid slide way (floating slide-way at request for raw workpiece), work stop, pair of positioning keys **h6**, cover for protection of the screw, 4 clamps, pair of parallels, wooden box.

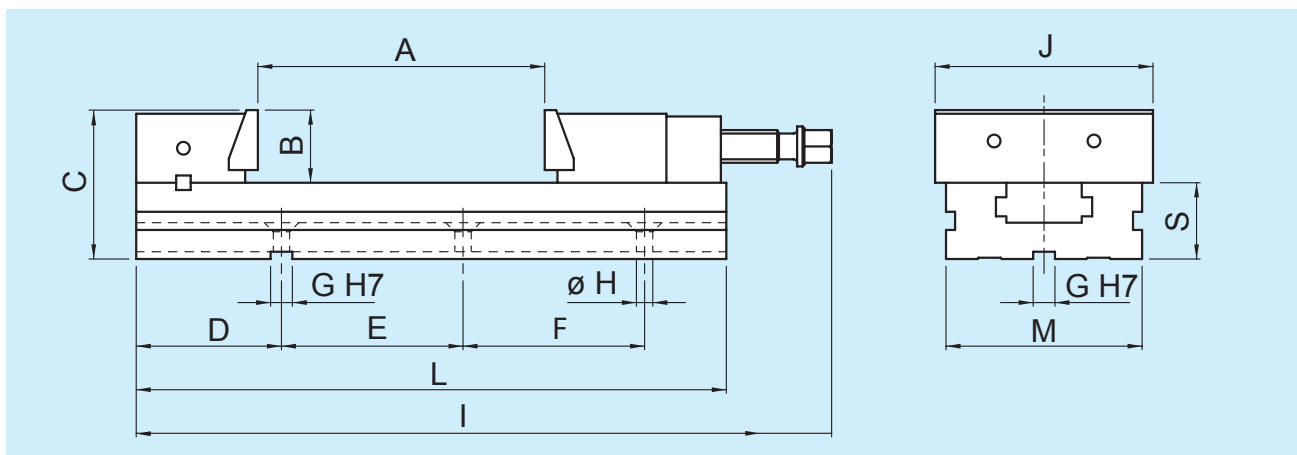

Cod. Nr.	Modello Type	A mm	B mm	C mm	D mm	E mm	F mm	G mm	H mm	I mm	J mm	L mm	M mm	S mm	Peso. Weight kg
33 58 06 21	MC 150 x 200	200	50	102	120	200	-	18	12,5	482	150	415	128	52	25,5
33 58 06 22	MC 150 x 250	250	50	102	120	100	100	18	12,5	532	150	465	128	52	27,5
33 58 06 23	MC 150 x 300	300	50	102	120	100	100	18	12,5	587	150	520	128	52	30,4
33 58 07 21	MC 200 x 300	300	70	136	150	150	150	18	12,5	656	200	570	168	66	66

La nuova MORSA **LC** si affianca alle originali OML **TC** ed **MC** come soluzione "low cost".

The new **LC VISE** joins the original OML **TC** and **MC VISES** as "low cost" solution.

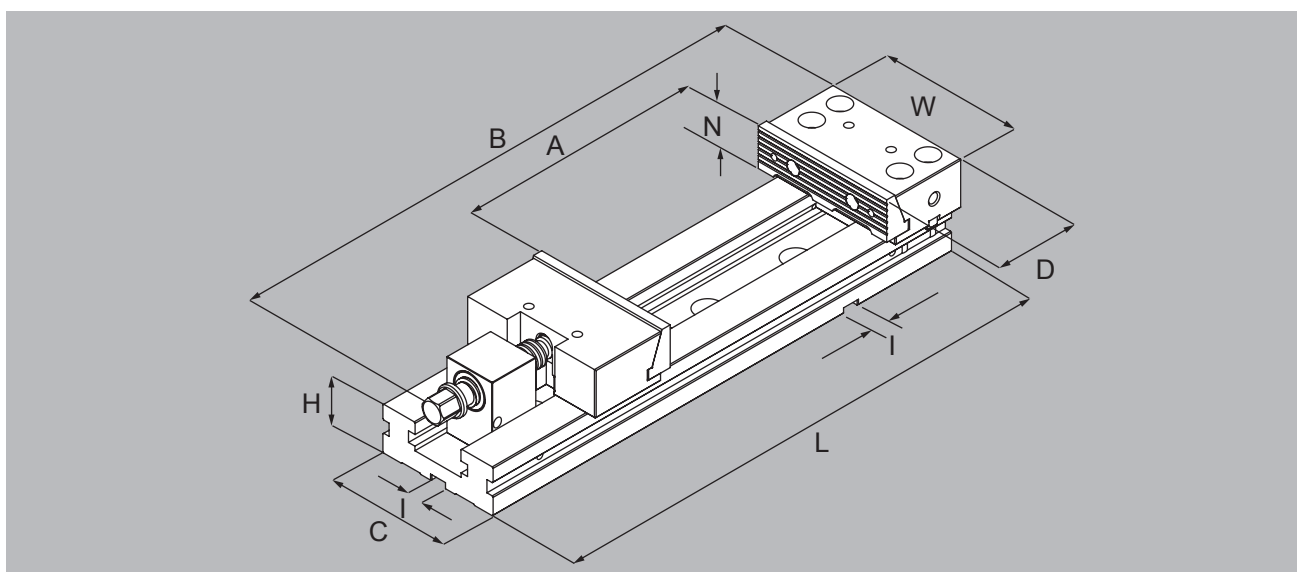

Cod. Nr.	Modello Type	W mm	N mm	A mm	L mm	B mm	C mm	D mm	H mm	I mm	Peso. Weight kg
77 58 95 01	LC 125 x 150	125	40	150	345	410	95	77,9	40	16	13
77 58 96 01	LC 150 x 200	150	50	200	420	500	125	89,4	50	16	26
77 58 96 02	LC 150 x 300	150	50	300	520	600	125	89,4	50	16	29
77 58 97 01	LC 200 x 300	200	65	300	595	680	170	113	70	16	69
77 58 97 02	LC 200 x 400	200	65	400	695	780	170	113	70	16	74

CUBI SGROSSATI TOMBSTONES ROUGH MILLED



Cod. Nr.	Prezzo.Price	Offerta.Offer
57 40 60 36	€ 3.111,00	€ 1.533,00
57 40 60 56	€ 4.290,00	€ 2.020,00
57 40 60 91	€ 6.080,00	€ 3.253,00
57 40 61 21	€ 8.259,00	€ 6.300,00

SPALLE SGROSSATE CRANKWEBS ROUGH MILLED



Cod. Nr.	Prezzo.Price	Offerta.Offer
57 40 90 26	€ 3.085,00	€ 1.533,00
57 40 90 46	€ 3.866,00	€ 2.020,00
57 40 90 66	€ 5.891,00	€ 3.253,00
57 40 90 91	€ 8.079,00	€ 6.300,00

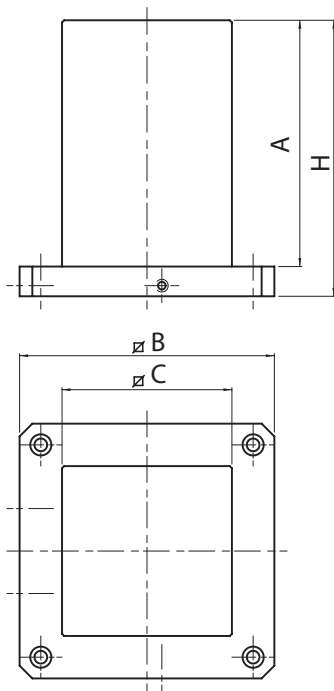

I cubi e le spalle in offerta sono in fusione di ghisa GJL 300.

Il prezzo include la lavorazione per l'interfaccia al pallet della macchina utensile come da normativa **JIS**, (macchine utensili giapponesi), e la sgrossatura delle facce con 4 mm di sovrametallo sul totale.

A richiesta la base può essere lavorata secondo specifiche del cliente.

The tombstones and the crankwebs in the offer are in cast iron GJL 300.

*The price includes the working for the adaptation to the machine tool pallet according to the **JIS** specifications, (japanese machine tools), and the faces are rough milled with 4 mm of overall material. Upon request the base can be machined following customer's specifications.*

GHISA
CAST IRON

Cod. Nr.	A mm	B mm	C mm	H mm	Peso, Weight kg
57 40 60 36	615	400	254	660	208
57 40 60 56	655	500	354	700	329
57 40 60 91	810	630	454	860	607
57 40 61 21	945	800	554	1.000	808

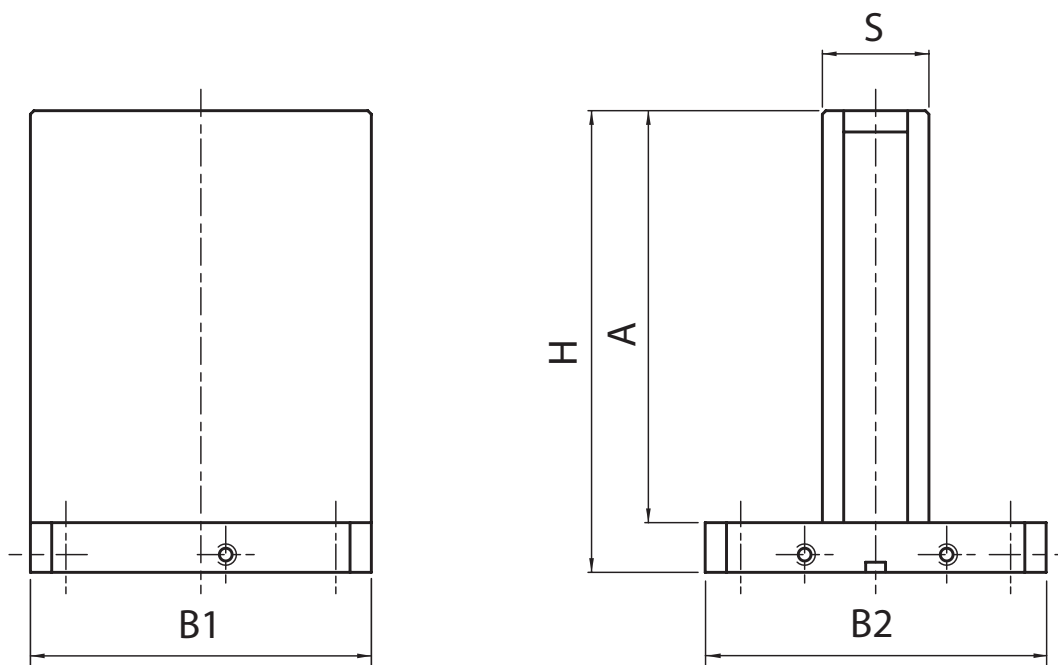

GHISA
CAST IRON

Cod. Nr.	A mm	B mm	H mm	S mm	Peso, Weight kg
57 40 90 26	615	400	660	154	185
57 40 90 46	655	500	700	154	247
57 40 90 66	810	630	860	204	448
57 40 90 91	945	800	1.000	304	810



SISTEMI MODULARI DI BLOCCAGGIO
MODULAR CLAMPING SYSTEMS



AZIENDA CON SISTEMA
DI GESTIONE PER LA QUALITA'
CERTIFICATO DA DNV
UNI EN ISO 9001:2000



APS
Automatic Positioning System

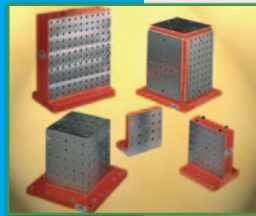

CUBI
TOMBSTONES



MORSE TC
TC VISES

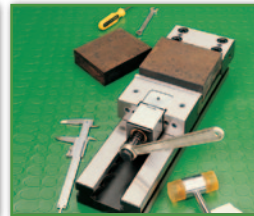

MORSE MC
MC VISES

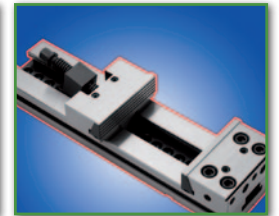

MORSE LC
LC VISES

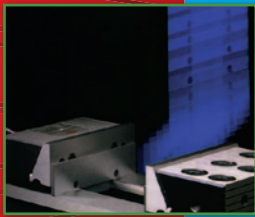

CLAK SYSTEM
Cambio rapido-Quick change

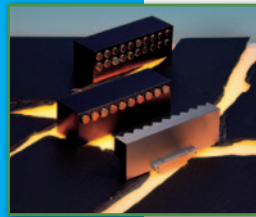

MULTI GRIP

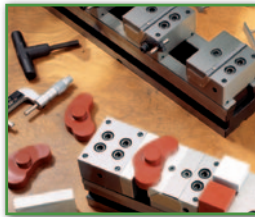

CIVI 2000
Multibloccaggio-Multiple clamping



CAM SYSTEM



MORSE MR
MR VISES

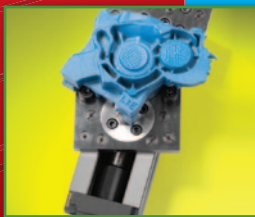

Vari CLAMP



NCN morse con moltiplicatore
Clamping force-multiplicator vises



DUO - LOCK

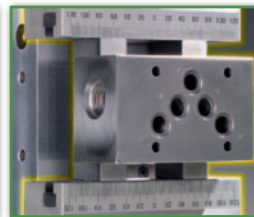

Ganasce e accessori
Jaws and accessories

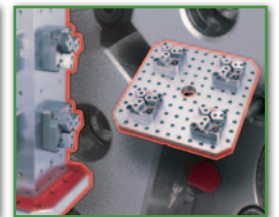

SC mandrini autocentranti statici
Static chucks

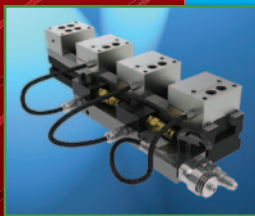

CIVI HYDRO



FAST CLAMP

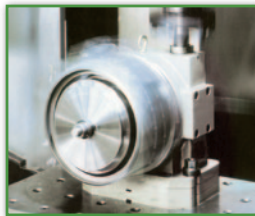

TOUCHDEX
Tavole indexate - Indexing tables



GENIUS
5 axis

OFFICINA MECCANICA LOMBARDA S.p.A.

Via Cristoforo Colombo, 5
27020 Travacò Siccomario (PV) - ITALY
Tel. +39 0382 55 96 13
Fax +39 0382 55 99 42
e-mail: omlspa@omlspa.it
www.omlspa.it

Offerta Speciale fino ad esaurimento scorte - Special Offers until end of the stock